

Packaging & Packing Instructions

Amscan packing and packaging requirements

TOPS and its importance

Packaging is designed using Total Optimization Packaging and Palletization Software (TOPS). Every new product is put through the TOPS program to determine the most efficient use of space (dimensions), as well as effective carton weight. For existing products, the inner pack dimensions and weight may be used to develop new master carton packaging. The program will generate several inner and master carton packaging options and pallet designs based on desired parameters.

Five key reasons why it is important for you to follow the requested packaging:

1. If the master carton is too large, it will not fit into the flow racks and the inners will have to be hand-stacked. Flow racks have an opening of 17". The width of the master carton must be under 17".
2. If the flap orientation is not as requested, a cut to the side of the master carton open in the flow racks, which can lead to damaged product.
3. Master carton weight can not be above 40 lbs. For safety and efficiency, the weight and inner carton quantity may need to be reduced.
4. Inner pack quantity must be as requested.
5. Packaging too large for the product may result in crushed cartons when stacked which in turn will cause wasted space and possibly damages.

For most products, only one each is available for packaging design. In this case, we will generate estimated packaging dimensions and weights. This packaging is developed as a guideline to illustrate our desired inner pack quantity and orientation in the master carton. Flap orientation of the master carton is important. A 1" variance in any dimension on the master carton is acceptable. Penalties will be assessed with variances over 1" if the dimensions are not approved by warehouse management. If your packaging is not within this tolerance, please contact the Tops Engineer with your suggested dimensions. Your recommendations will be evaluated for acceptance or you will be instructed to re-design the master carton based on your inner pack dimensions. **These dimensions must be approved by Amscan prior to purchasing packaging materials.**

Pallet Loads

Palletized loads are not to exceed the maximum height of 54" including the pallet. Any items requiring pallet stacks higher than 54" must get approval from the Amscan Distribution Center prior to shipping. Only GMA standard wooden pallets 40" x 48" grade B or higher should be used. TOPS shows recommended pallet designs based on calculated master carton dimensions. Please refer to this pallet design to ensure proper pallet configuration. A variance of 1" in one or more dimensions of the master carton may not allow for the desired pallet configuration. Please notify the Tops Engineer if you cannot fit at least the specified master carton quantity on a pallet. There should be no overhang front to back; there can be some overhang side-to-side but no more than 1" unless otherwise approved. All pallet loads should be secured and wrapped appropriately for the product to arrive at the Distribution Center intact. Double stacked pallet loads are acceptable for domestic shipments, unless damages are occurring. Amscan may exercise the right to require vendors to single stack, add corner supports, slip-sheets, or other securing methods for future shipments, this will minimize your damages and enable us to lessen the double handling of product. In the event shipments arrive at the DC and are not compliant with

Section – 3b (Wholesale)

Pallet load specifications, damaged or require restacking, vendors will be charged back for additional handling and/or the shipment refused.

Existing product with TOPS specifications

Please check your files thoroughly. If for any reason, on a specific item number you need any additional copies of the TOPS form, please let the TOPS Engineer know immediately. You will need to verify this list and let the TOPS Engineer know of any discrepancies or additional information needed within the next thirty (30) days. In any case where there is differing information on the Amscan purchase order, please contact your product manager and the TOPS Engineer to confirm the correct quantities.

Existing product without TOPS specifications

On any other product you are shipping to us, please continue shipping as you have been. Any changes you wish to make on existing product must be communicated to and approved by Amscan.

We are reviewing all current product in our distribution center. Any item which is an issue due to weight or size causing us undue material handling may be reviewed and reassessed. In that case, a TOPS form will be forwarded to you.

We are charging you as our business partner, with the responsibility of understanding and complying with Amscan's TOPS program on all new product moving forward. This pertains to all product sold to Amscan.

How to read a TOPS form

Once a TOPS form has been created, it will be emailed to you by the TOPS Engineer. You will need to review the TOPS form and advise the TOPS Engineer that you agree to the packing that is shown in the form. If you do not agree to the packing method, contact the TOPS Engineer to resolve any problems before the item is shipped to avoid any penalties.

TOPS examples are shown on the next three pages. The first page is in English units of measure (inches and pounds) and the second page is in Metric units of measure (millimeters and kilograms).

Section **A** shows the packing of the eaches in the inner carton and identifies the number of eaches per inner. The dimensions are also listed. In the example, the eaches are packed in a poly-bag inner. If the eaches are in a corrugate inner box, this will be visible in the picture.

Section **B** shows the packing of the inners in the master carton and lists the number of inners per master. The dimensions are also listed. The master carton will always be shown as corrugate carton. Please note the orientation of the inners in the master.

Section **C** - This section is only for vendors shipping product to us on pallets and for warehouse use.

Section **D** is a summary of the carton information. "Carton (OD)" is the measurements of inner carton. "Shipper (OD)" is the measurements of the master carton. (Ln = Length, Wd=Width, Ht=Height, and Grs=Gross Weight)

Notes: Any additional packing notes are listed in this section. If the inner is a poly-bag, this will be noted in this section. This section will list all of the items that this form applies to.



Section – 3b (Wholesale)

The third page shows an example where the number of eaches in the inner is equal to the number of eaches in the master. Since there are no inner cartons, only the master carton is shown. This carton should have a master carton label with a 300 series (inner carton) barcode.

Please contact the TOPS Engineer for any questions concerning packing requirements that are not listed in the TOPS form.

TOPS Engineer

Nettie Thompson

E-mail : nthomps@amscan.com

Phone: 845-572-2151

TOPS Manager

Paula Kochon

E-mail : pkochon@amscan.com

Phone: 845-469-9116 ext. 2133

EXAMPLE OF ACTUAL TOPS FORMS

Section – 3b (Wholesale)

123456-PARTY ITEM

Tops Engineering

8/5/2005

A.

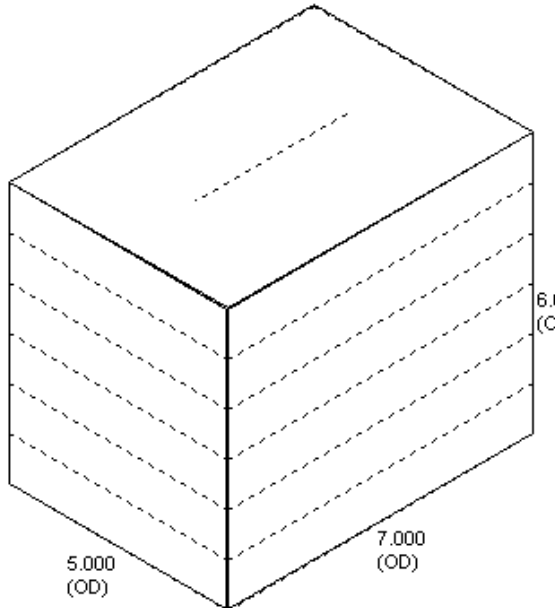

6 EACHES PER INNER

B.

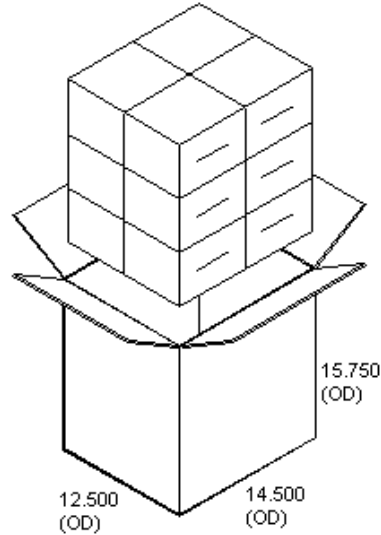

12 INNERS PER MASTER

C.

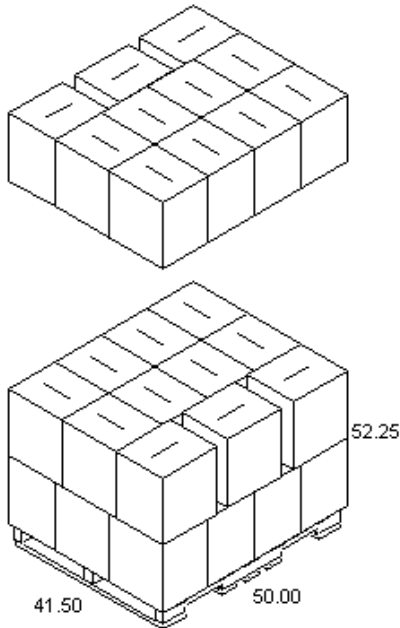

D.

GMA (Notched) 48.00x40.00x5.00

	Carton (OD)	Shipper (OD)	Unit Load (Incl. Pal)
Ln:	7.000 in	14.500 in	50.00 in
Wd:	5.000 in	12.500 in	41.50 in
Ht:	6.000 in	15.750 in	52.25 in
Net:	0.000 lb	0.000 lb	0.000 lb
Grs:	2.547 lb	31.619 lb	1093.439 lb
Cube:	210.00 in ³	1.6520 ft ³	62.7423 ft ³
	Height Vert	Height Vert	
Carton:		72	2376
Carton:		12	396
Shipper:			33
Area Efficiency:		97.2 %	103.8 %
Cubic Efficiency:		96.4 %	96.2 %
Cases per layer:			11
Layers/load:			3
Pattern:		2x2x3	Interlock
RSC Area:		10.59 ft ²	350 ft ²

Notes: Inner is a polybag. Close and securely tape the polybag to prevent the eaches from falling out. This form applies to items 123456 and 123457. All measurements are approximate.

3:41 pm

Nettie Thompson, Page 2

Vendor Acceptance of Design: _____ Date: _____

Section – 3b (Wholesale)

123456-PARTY ITEM

Tops Engineering

8/5/2005

A.

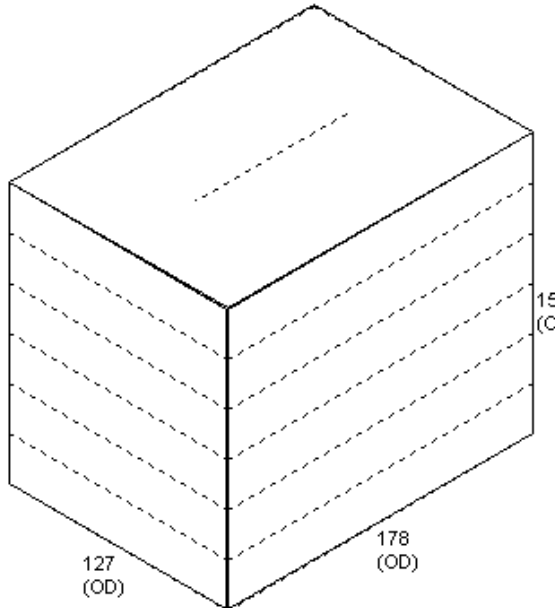

6 EACHES PER INNER

B.

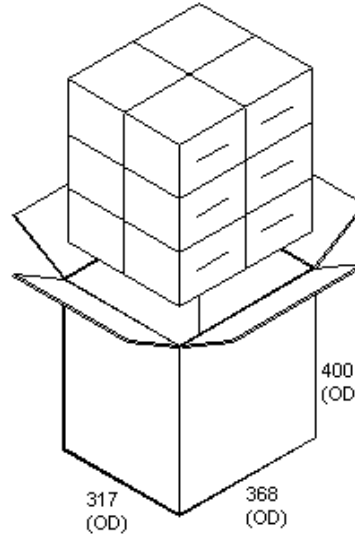

12 INNERS PER MASTER

C.

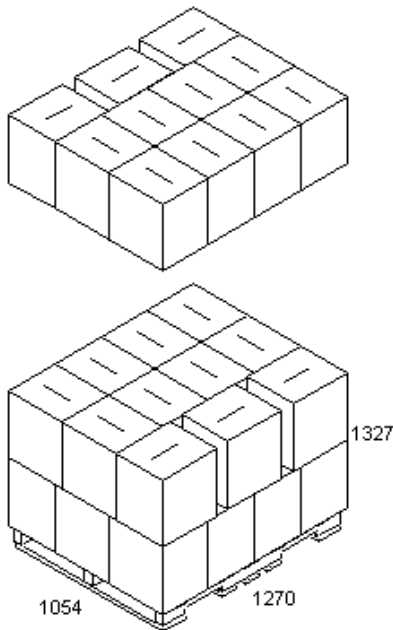

D.

GMA (Notched) 1219x1016x127

	Carton (OD)	Shipper (OD)	Unit Load (Incl. Pal)
Ln:	177.80 mm	368 mm	1270 mm
Wd:	127.00 mm	317 mm	1054 mm
Ht:	152.40 mm	400 mm	1327 mm
Net:	0.00 kg	0.000 kg	0.000 kg
Grs:	1.16 kg	14.342 kg	495.973 kg
Cube:	3.4 l	0.0468 m ³	1.7767 m ³
	Height Vert	Height Vert	
Carton:		72	2376
Carton:		12	396
Shipper:			33
Area Efficiency:		97.2 %	103.8 %
Cubic Efficiency:		96.4 %	96.2 %
Cases per layer:			11
Layers/load:			3
Pattern:		2x2x3	Interlock
RSC Area:		0.98 m ²	32 m ²

Notes: Inner is a polybag. Close and securely tape the polybag to prevent the eaches from falling out. This form applies to items 123456 and 123457. All measurements are approximate.

8:43 pm

Nettie Thompson, Page 2

Vendor Acceptance of Design: _____ Date: _____

Section – 3b (Wholesale)



Tops Engineering

12345-PARTY ITEM INNER=MASTER

Date Printed : 4/10/2007
Last Saved : 4/10/2007

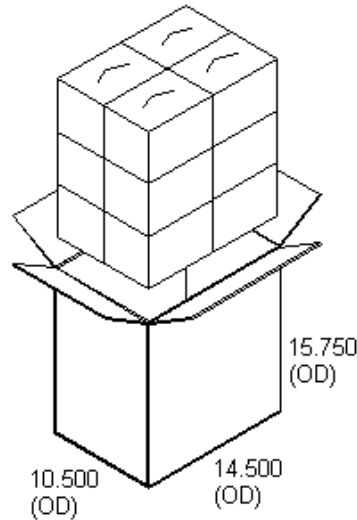

12 EACHES PER INNER, INNER CARTON = MASTER CARTON

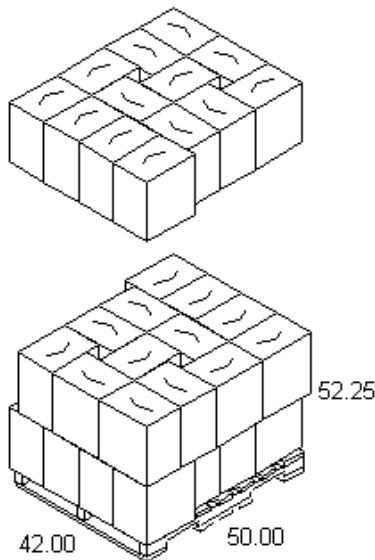

GMA (Notched) 48.00x40.00x5.00

	Carton (OD)	Shipper (OD)	UnitLoad (Incl. Pal)
Ln:	7.000 in	14.500 in	50.00 in
Wd:	5.000 in	10.500 in	42.00 in
Ht:	5.000 in	15.750 in	52.25 in
Net:	0.000 oz	0.000 lb	0.000 lb
Gr:	32.000 oz	24.911 lb	1036.547 lb
Cube:	175.00 in ³	1.3877 ft ³	63.4983 ft ³
	Height Vert	Height Vert	
Carton:		12	468
Shipper:			39
Area Efficiency:		96.9 %	103.1 %
Cubic Efficiency:		96.1 %	95.5 %
Cases per layer:			13
Layers/load:			3
Pattern:		2x2x3	Diagonal
RSC Area:		9.11 ft ²	355 ft ²

Notes: The inner/master must be a strong double walled corrugate carton. All measurements are approximate.

Vendor Acceptance of Design: _____ Date: _____

Quality Control guidelines

In addition to our TOPS Program, Quality Control is another issue of paramount importance.

The following are Quality Control guidelines all Vendors must adhere to. While many of these guidelines seem like good, practical common sense, the daily abuse encountered at all of Amscan Distribution Centers warrants the reiteration of the guidelines below. Failure to comply with any of the below requirements will result in charge backs (see section 8 Reimbursement and Waiver Policy).

Labeling Requirements

- Labeling is checked on the master, inner, and eaches.
- Julian Date Coding is required on the master carton, inner pack and eaches.
- Labeling for master carton, inner pack and eaches must all have a scannable bar code.
- Each label has its own set of specifications. Refer to the separate sections for label requirements.

UPC/Bar Code Requirements

- UPC's are checked for scannability and for the correct readable digits printed below the bar (human readable).
- Bar Codes are scanned for correctness. All bar codes must scan and verify against ANSI standards with a grade of "C" or better.
- It is the vendor's responsibility to ensure correct scannability of all bar coding.

Packaging

- Packaging is checked to make sure that inners per master, eaches per inner, and eaches per master are correct according to Amscan's specifications.
- Packaging is checked to make sure correct packaging is used for each product if required (example: bubble wrap, corrugated inserts, special packaging if required / necessary).
- If poly-bags are to be used for inners, they must be a minimum of a 3 mil polyethylene bag.
- No strapping to be used on master cartons (do not strap 2 master cartons together).
- No staples to be used on master cartons.
- No sub masters are ever to be used.

Quality/Artwork

- Product is checked against the approved sample by the Product Manager or catalog copy.
- Item packaging is checked for new artwork and color schemes.
- Any quality defects are the responsibility of the maker. Chargebacks will be issued for any product which requires re-working or replacement.

Dimensions & Weight

- Measurements and weights are checked by the Cubiscan team and must meet all Amscan and TOPS requirements.
- No master carton should exceed the weight of 40 lbs. You must have approval from warehouse management prior to shipment being made if the weight of the master carton exceeds 40lbs.
- **MINIMUM MASTER CARTON SIZE:** 12" Length x 12" Width x 12" Height (prior approval is needed for any master carton deviating from the minimum carton size)
- **MAXIMUM MASTER CARTON SIZE:** 20" Length x 17" Width x 16" Height. (prior approval is needed for any master carton deviating from the maximum carton size)
- Final weights and dimensions of master cartons must be supplied to Amscan no later than 2 weeks prior to shipment.
- For items where the number of pieces in the inner is equal to the number of pieces in the master, the dimension requirements do not apply.

Master Carton

- Carton should always be made of durable, double-walled, shippable corrugate.
- Masters weighing up to 20 lbs, the minimum requirements are a 200 lbs per square inch (14.1 kg per square cm) bursting test or a 32 lbs per inch (5.7 kg per cm width) edge crush test.
- Masters weighing over 20 lbs, the minimum requirements are a 200 lbs per square inch (14.1kg per square cm) bursting test or a 48 lbs per inch (8.6 kg per cm width) edge crush test.
- You may not mix SKUs in a Master.
- **MASTER CARTON PACKS:** This should be done in an even number amount of inners. (i.e.: 4, 6, 12, 18, 36, etc.) Variances must be approved prior to shipment. We will not accept 2 inners per master. These items should either be changed to 3 inners per master or the inner should equal the master.

CONEG: Packaging Requirement

Manufacturers and suppliers of packaging and packaging components are required by law to furnish a certificate of compliance to customers upon request (refer to the introduction section). This applies only to companies who actually put their products in the package and does not apply to the retailer or the individual consumer. The public and state also have access to these certificates.

Should there be any problems after cartons are received, or there is non-compliance with the above criteria, a redesign will be done to comply. Watch this very carefully so that this process and potential charge backs can be avoided. Failure to meet the Quality Control guidelines will result in penalties as listed in Section 8 (Reimbursement And Waiver Policy) and Section 9 (Terms and Conditions).

Traceability

Children’s products will need permanent distinguishing marks on the product, to the extent practicable, to identify the manufacturer, location, date of production and other necessary information for all goods manufactured on or after 8/14/09.

Amscan Labels

Master Carton Labels

Amscan uses a sophisticated warehouse management system. The labeling of all master cartons according to the following guidelines will assist in maintaining accurate inventory levels at our distribution centers and will make it easier to service our customers. All efforts to meet these specifications must be made. Any questions regarding this should be handled with Kim O’Shea at fax number: 845-572-2178.

Master Carton Label Guidelines

- White labels with Black print are to be used unless specifically directed otherwise.
- Bar Code is interleaved 2 of 5, 14 digits or standard subset, 6 symbology.
- Bar Code must be scannable.
- Width of the narrow bar and space between bars to be a minimum of .015” (or 15mil).
- Minimum bar code height is ½”
- The bar code must be printed on the label to allow at least ¼” white zone around the entire perimeter of the bar code.
- Label Size: 6” x 4” minimum; 6” x 6” maximum. (If label size is larger than the master carton, smaller labels may be used upon approval.)
- Use 2 labels per carton on adjacent sides
- Do not place label over sealing tape where box flaps join.
- Labels MUST be in type, NO handwritten labels
- The following information must be on all Master Carton labels:
 - Amscan Item Number
 - Unit of Measure Conversion:
 - EA/IP = Eaches per Inner pack (retail units per selling unit)
 - IP/MC = Inner pack per Master Carton (selling units per purchasing unit)
 - Total number of eaches in the Master Carton
 - Amscan Item Description
 - Amscan Purchase Order Number
 - Your Amscan Vendor Number
 - Country of Origin
 - Amscan name and locations
 - The 14 digit interleaved 2 of 5 Bar Code with the horizontal lines all printed.
 - Human readable digits of the Bar Code printed directly underneath bars
 - Production code printed below the Bar Code – (Julian Date Code) Example - June 1, 2009 to read as follows 09152.

Master Carton Label Placement

The location of the Interleaved 2 of 5 (SCC 14) Bar Code on each side is as follows:

- Bottom of the bars must be be 1.25" (+/-0.25") from the bottom of the carton.
- The clear areas on the sides of the bar code must be at least 0.75" from both edges of the carton.
- Interleaved 2 of 5 (SCC-14)
- See diagrams below for label placement

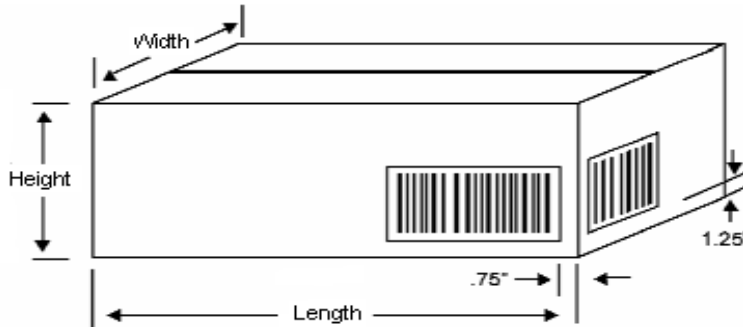

Master Carton Label Example

58011
 10 INNERS X 12 PKGS = 120/MSTR
 PANSIES 9 oz CUP

PO# 999999 VENDOR # 999999
 MADE IN USA Amscan Inc.

Elmsford NY 10523 USA
 Canada Dorval PQ H9P 2T8
 England Milton Keynes MK10 0DA

50048419078680
09152

* 500-Series bar code denotes this carton is a Master.

When the number of pieces in an inner carton equals the number of pieces in the master carton or the distribution will be done only by the complete Master Carton, the barcode should be the 300 series with all master carton information as shown on the example below.

123456

1 Inner X 12 eaches = 12/master

4" X 6" vertical window frame

PO#55555

Vendor #999

Made in China

----- Amscan Inc.

Elmsford, NY 10523 USA
Canada Dorval PQ H9P 2T8
England Milton Keynes MK10 0DA

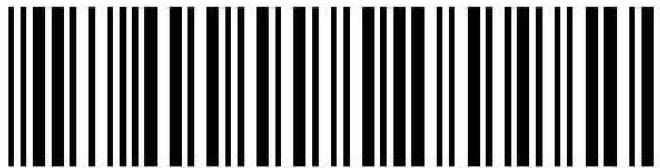

30048419648209

09152

Inner Carton Labels

Inner Carton Label Guidelines

- White labels with Black print are to be used unless specifically directed otherwise
- Bar Code must be scannable
- Label Size: 4 5/8" Wide x 3 1/2" High (If label size is larger than the inner carton, smaller labels may be used upon approval.)
- Place label on the inner carton so that the inner label is showing when the master carton is opened. If the side that is facing out when the master carton is opened is too small to fit the label, the largest size may be used.
- The following information must appear on the label:
 - Amscan Item Number
 - Number of packages in the inner
 - Amscan product description
 - Amscan name and locations
 - Bar Code, interleaved 2 of 5, 14 digits
 - Human readable digits of the Bar Code printed directly underneath bars
 - Production code printed below the Bar Code – (Julian Date Code) Example - June 1, 2009 to read as follows 09152.

Inner Carton Label Placement

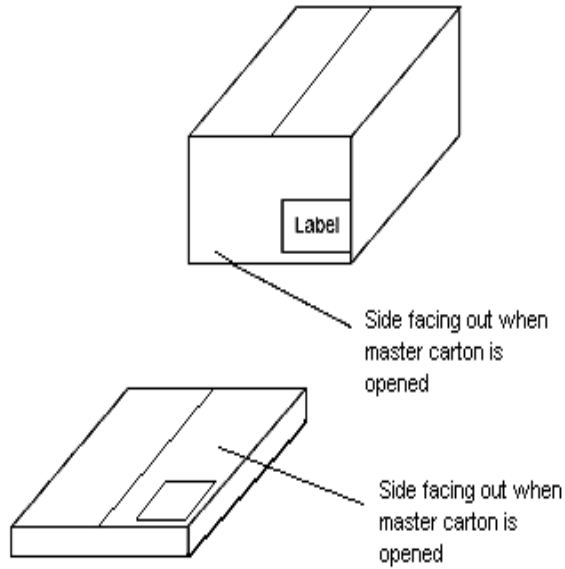

Inner Carton Label Example

390505 **6 PKG**
45MM PSYCHEDLIC BOUNCE BALL HC
Amscan Inc. Elmsford NY 10523 USA
Canada Dorval PQ H9P 2T8
England Milton Keynes MK10 0DA



30048419614143
09152

* 300 – Series bar code denotes this carton is an Inner.

Section – 3b (Wholesale)

Eaches Labels

The correct printing of clear UPCs is of primary importance due to market sensitivity. If an incorrect UPC is printed, or the UPC is un-scannable, there will be a chargeback without warning due to the ramifications of the error.

All barcodes appearing on the label printed for Amscan’s use shall meet the specifications contained herein.

In most cases, Amscan provides the UPC artwork (included with the each packaging artwork) to our vendors. Whether or not Amscan supplies eaches label artwork, the vendor should pay specific attention to the following guidelines.

Eaches Label Guidelines

- White labels are to be used unless specifically directed otherwise
- Print in black
- All UPC's should be in standard UPC-A format and scan at the grade level of "C" or better
- Barcode must be scannable
- Label size needs to be an appropriate size for the item (no over hang)
One label is to be used unless the item/each come in a box, container, or display. In this case the box, container, or display AND the piece must each have the label.
- The following information needs to be on the labels
 - Amscan item #
 - Your Amscan Vendor Number
 - Country of origin
 - UPC/barcode
 - Human readable version of the bar field must appear directly below the barcode
 - Amscan name and locations (if applicable)
 - Production code printed below or to the side the Bar Code – (Julian Date Code)
 - Example – June 1, 2009 to read as follows 09152.

Eaches Label Examples

EXAMPLE OF AMSCAN ITEM UPC LABEL

Sample UPC has been enlarged for viewing

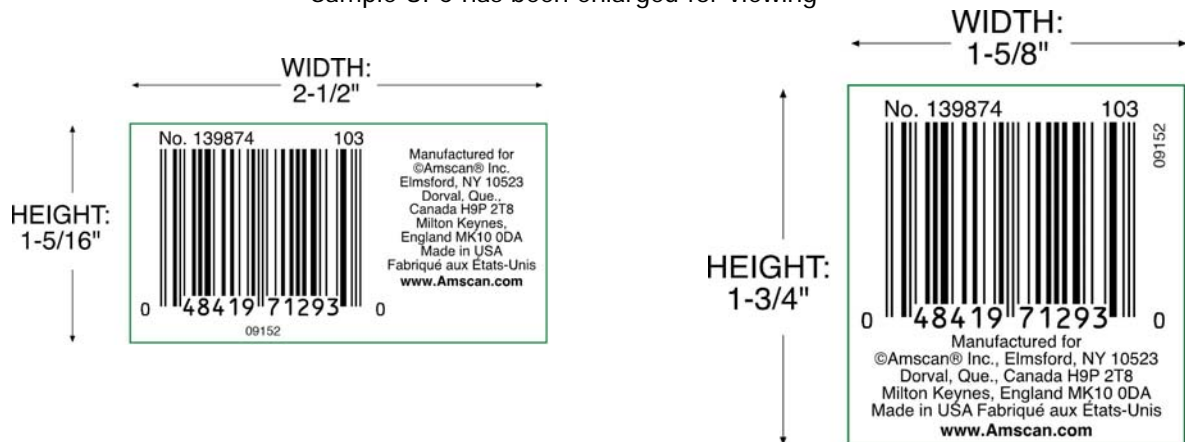

EXAMPLE OF GRASSLANDS ROAD ITEM UPC LABEL

Sample UPC has been enlarged for viewing

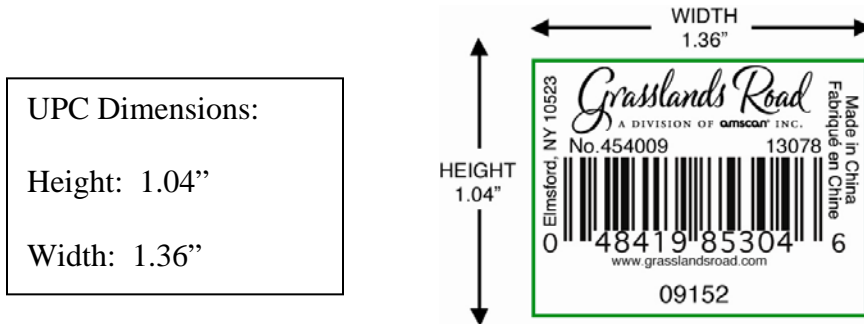

PACKAGING/LABELING FOR CANDY PRODUCTS

DATE CODE REQUIREMENT

For all candy products, we have instituted a specific date code requirement to identify the production date of the candy. This 10 digit identification number is referred to as the Lot Number.

The Lot Number consists of the calendar date of production placed between 2 pairs of numbers as follows:

Position #s start from left to right

- Positions 9 & 10: will list as 99 and will not change
- Positions 7 & 8: represents the month
- Positions 5 & 6: represents the day
- Positions 3 & 4: represents the last 2 days of the year
- Positions 1 & 2: will list as 00 (a constant number for now – however, this could potentially change if needed in the future)

An example of the Lot Number with the calendar date of January 1, 2008 would be listed as:

9901010800

An example of the Lot Number with the calendar date of April 25, 2008 would be listed as:

9904250800

Master Carton Lot Number

The Lot Number must be printed directly onto the Master Carton as large as possible. It must be printed on the top right hand corner on each side of the Master Carton. Please refer to the following example.

i.e. LOT # 9901010800



Inner Carton Lot Number

The Lot Number must be printed on the inner carton label as large as possible underneath the inner UPC code. Please refer to the following example.

i.e. LOT # 9901010800



Package Lot Number

The lot Number must be printed directly onto the package at the lower right corner of the package as legible as possible. Please refer to the following example.

i.e. 9912010700

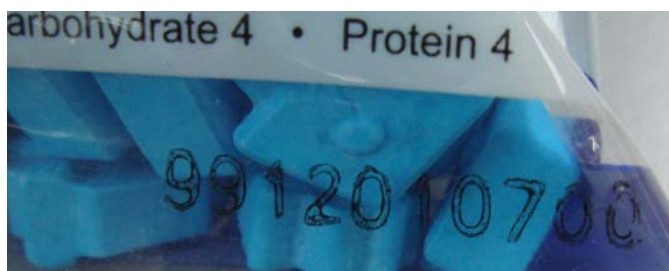

Manual calculation of the check digit for Amscan labels

Symbology for Inner and Master Label

Both use the Interleaved 2 of 5 (I 2/5) symbology with 14 digits of numeric data. The data looks like this:

_____ 13 _____ 12 _____ 11 _____ 10 _____ 9 _____ 8 _____ 7 _____ 6 _____ 5 _____ 4 _____ 3 _____ 2 _____ 1 _____ CH

where

digit #	definition
13	for the Inner, it is always a 3; for the Master, it is always a 5
12	always a zero
11 – 1	left most 11 digits from the UPC #
CH	check the digit calculated based on the other 13 digits

Calculation of the check digit:

1. Sum of the digits in the ODD positions and multiply the result by 3
2. Sum the digits in the EVEN positions and add to the above result
3. Find the digit to add to the result of 2. Above so that the new number ends in zero. That digit is the checksum digit.

Example: 43030.01 7" PLSTC PLATE 20 CT-REGL BLUE UPC 012795107581

Inner Box Bar Code

3 0 0 1 2 7 9 5 1 0 7 5 8

1. $3 + 0 + 2 + 9 + 1 + 7 + 8 = 30$
 $30 * 3 = 90$
2. $0 + 1 + 7 + 5 + 0 + 5 = 18$
3. $90 + 18 = 108$
 $108 + CH = 110; CH = 110 - 108 = 2$

Therefore, the Inner Box Bar Code is: 30012795107582

Master Box Bar Code

5 0 0 1 2 7 9 5 1 0 7 5 8

1. $5 + 0 + 2 + 9 + 1 + 7 + 8 = 32$
 $32 * 3 = 96$
2. $0 + 1 + 7 + 5 + 0 + 5 = 18$
3. $96 + 18 = 114$
 $114 + CH = 120; CH = 120 - 114 = 6$

Therefore, the Master Carton Box Bar Code is: 50012795107586