

Party City Holdings, Inc (PCHI)

Vendor Standards Manual (VSM)



Revised January 2017



Table of Contents

<u>Section</u>	<u>Title</u>	<u>Page #</u>
	Introduction	4
	2017 Vendor Standards Manual (VSM) Acknowledgement	6
1acd	Merchandise Information – Retail: Party City, Party America, Party City Canada, Halloween City	7
1b	Merchandise Information – Wholesale: Amscan, Anagram International, Grasslands Road	13
2acd	Electronic Data Interchange (EDI) – Retail: Party City, Party America, Party City Canada, Halloween City	18
3ac	Packaging and Packing Instructions – Retail: Party City, Party America, Halloween City	29
3b	Packaging and Packing Instructions – Wholesale: Amscan, Anagram International, Grasslands Road	38
3d	Packaging and Packing Instructions – Retail: Party City Canada	56
4acd	Product Safety Quality Assurance – Retail: Party City, Party America, Party City Canada, Halloween City	66
4b	Product Safety Quality Assurance – Wholesale: Amscan, Anagram International, Grasslands Road	71
5bd	Imports - Wholesale: Amscan, Anagram International, Grasslands Road	90
	Exports – Wholesale/Retail Canada: Amscan, Anagram International, Grasslands Road, Party City Canada	104
	Bypass – Wholesale: Amscan, Anagram International, Grasslands Road	110
6ac	Transportation Routing Guide – Retail: Party City, Party America, Halloween City	125



6b	Transportation Routing Guide – Wholesale: Amscan, Anagram International, Grasslands Road	134
7acd	Accounts Payable – Retail: Party City, Party America, Party City Canada, Halloween City	139
7b	Accounts Payable – Wholesale: Amscan, Anagram International, Grasslands Road	145
8	Reimbursement and Waiver Policy	149
9	Terms and Conditions	158
10	Code of Business Practices	167
11	Contact Information	170
12	Personalization and Custom Invitation – Retail: Party City	177
13	Partycity.com Web Fulfillment – Retail: Party City	180
	Appendix	183

Introduction

Within this Vendor Standards Manual (VSM) you will find a set of performance expectations. Rather than being all-inclusive, our expectations are intended to better define elements of your role in servicing our organization. They do not replace good business practices, legal requirements or the need to use common sense when managing our business. The Vendor Standards Manual covers vendor requirements for Party City Holdings, Inc. (PCHI) and its subsidiaries which include both corporate and franchise retail locations. These standards will be supplemented from time to time with changes emailed to the vendor contact on record.

Vendor Participation Agreement (VPA)

PCHI maintains a vendor database containing payment terms and contact information. Contact information includes a primary contact person as well as contacts in sales, accounts receivable, marketing, logistics, quality control and electronic data interchange (EDI). Each contact must include first and last name, address, phone, fax, and email address. It is the responsibility of each vendor to ensure all information contained in this database is accurate by completing a Vendor Participation Agreement.

The VPA form review will occur once a year. However, if no changes are required, the most current VPA remains in effect until mutually cancelled or replaced by a more recent revision.

Changes to Vendor Information

Documentation must be on company letterhead and signed by a senior officer of your company. All changes must be received 14 days prior to their effective date.

Changes would include, but are not limited to:

- Change in Company Name or address (Remittance, shipping, or Return to Vendor addresses)
- Start, change or termination of a factoring relationship
- Change in company ownership: If a change in ownership occurs and the new owner is not currently in our vendor file as an authorized vendor, the company will be considered a new vendor and may be required to complete a *New Vendor Package (NVP)*.
- Change in legal structure
- Bankruptcy Filings

The letter communicating changes must contain the following information:

- Your company name and PCHI vendor number
- Statement of the change being communicated
- Signature of a senior officer or agent

Do not send any vendor updates or changes to store locations. Store personnel cannot approve or process any vendor changes.

Changes related to factoring relationships must include:

- Written or emailed confirmation from the factor terminating the relationship
- Written or emailed confirmation from the new factor (if applicable)
- Effective date and authorization to release payment to the new factor



For Party City (retail), changes should be emailed to vendorrelations@partycity.com or faxed to 973-983-4915 with a follow-up email to the lead Merchant.

For Amscan (wholesale), changes should be emailed to vendorrelations@amscan.com or faxed to 914-784-4302

For Anagram International, changes should be emailed to vendorrelations@anagramintl.com or faxed to 952-949-6491

PCHI reserves the right to hold payments pending receipt of this documentation.

Non-Merchandise

For all Non-Merchandise related issues, standards and guidelines can be found in a separate manual distributed by the Construction/Facilities team. Freight collect vendors must still adhere to guidelines set in the Transportation Routing Guide, Section 6 of this manual.

Please Note:

PCHI is both a wholesale and retail organization. For your convenience, the sections are divided in the following manner:

Section A - is for vendors that ship directly to our US retail locations

Section B - is for vendors shipping to our wholesale locations

Section C - is for our vendors shipping to Halloween City (HC)

Section D - is for vendors that ship to our Canada retail locations (Party City Canada)



PCHI Notification and Acknowledgement of 2017 Vendor Standards Manual (VSM)

Name of Parent Company: _____

Name of all Subsidiaries: _____

Some aspects of the VSM do not pertain to Sub-Vendors, many aspects do. Sub-Vendors should read the Vendor Standards Manual. The VSM applies to all vendor/sub-vendors shipping to all Party City Holdings Inc (PCHI) including its subsidiaries and affiliates which consist of, among others, entities doing business under Party City, Party America, Halloween City, Party City Canada, Anagram International, Grasslands Road and Amscan tradenames.

_____ (Company Name) understands it is our responsibility to complete a Vendor Participation Agreement (VPA) and return to Party City or Amscan in a timely fashion. Vendor is to furnish PCHI with up to date information. Vendor should submit all changes to vendor information on company letterhead signed by an executive. For Party City, changes should be emailed to vendorrelations@partycity.com or faxed to 973-983-4915. For Amscan, changes should be emailed to vendorrelations@amscan.com or faxed to 914-784-4302. For Anagram International, changes should be emailed to vendorrelations@anagramintl.com or faxed to 952-949-6491.

_____ (Company Name) understands it is our responsibility to provide PCHI with a *Certificate of Insurance* and furnish PCHI with the latest certificate, records, and all applicable documentation. We will replace the Certificate of Insurance if changes or expiration occur. Please refer to the Terms and Conditions, Section 9.

_____ (Company Representative) warrants that he/she is authorized to bind _____ (Company Name) to the representations contained herein and acknowledges that PCHI is relying on this representation to move forward.

_____ (Company Name) has read, understands, and agrees to the Terms and Conditions, Section 9 and all other applicable sections of the VSM.

Authorized Company Representative (Print Name): _____

Title: _____

Signature: _____

Date: _____

Contact Information: _____

All vendors that ship direct to Party City retail locations must fax or email this acknowledgement form to 973.983.4915 or vendorrelations@partycity.com.

All vendors that ship to Amscan/Grasslands Road must fax or email this acknowledgment form to 914.784.4302 or vendorrelations@amscan.com.

All vendors that ship to Anagram International must fax or email this acknowledgement form to 952.949.6491 or vendorrelations@anagramintl.com.

Section – 1a,c,d (Retail)

Merchandise Information

Overview – Party City (includes Party City, Party America, Party City Canada, and Halloween City)

This section outlines the general guidelines for Purchase Order (PO) requirements, product requirements, and UPC usage requirements.

All forms referenced in this section can be found in the Appendix. The New Item Form is available on the internet at www.partycityvendors.com.

Changes to Product Information

Any changes (i.e. to the pricing, product, discontinuation, UPCs, item#, case packs, inner packs, product dimensions, shipping case dimensions, or packaging) must be stated in writing or e-mail and presented to the appropriate Merchandising Manager for approval. Notification of everyday item changes must occur 60 days prior to the effective date. Notification of seasonal item changes must occur 60 days prior to the expected order placement date.

PO Requirements

Our goal is to offer merchandise that presents value and is consistently in stock at a price to satisfy our customers. Vendor must verify the accuracy of, and adhere to, all data on all POs, Corporate, Canadian, and Franchise.

If you have questions regarding a Corporate PO, contact the following department for each specific instance:

PO Contacts

- Planning and Allocation Manager -- Every Day/Replenishment orders- quantities or in-store dates
- Merchandise Manager -- All Seasonal orders- quantities or in-store dates; All item specific issues including incorrect costs, UPC's, case pack, vendor item numbers, etc...
- New store orders -- Email ckalman@partycity.com
- Franchise stores -- All franchise PO questions regarding quantities or dates - (Item specific issues, contact Merchandise Manager)

Vendors must utilize the “**Ship To Bill To (S2B2)**” file to determine if an order is for a corporate, Canadian or franchise store. If you are not receiving periodic updates via email broadcast, email Caryl Kalman at ckalman@partycity.com to be added to the distribution list.

Purchase Order Confirmation (Corporate, Canadian, and Franchise):

Vendors must be capable of receiving Party City POs via Electronic Data Interchange (EDI) transmittals. All vendors must be able to process EDI documents. For more information on EDI, reference Section 2.

Section – 1a,c,d (Retail)

In order to achieve our goal of having the right merchandise at the right time, we must ensure our vendors ship the exact merchandise and quantities ordered on a PO. Listed in this section are ways we can achieve our goal:

- Vendor must be in receipt of a valid PO prior to shipping any product. The PO number must not be modified in any way.
- Party City PO number is unique for each order and should not be in vendor system more than once. Vendor's system must prevent duplicate PO's in their system. Duplicate PO's will be subject to reimbursement as listed in the Reimbursement and Waiver Policy, Section 8. All rewrites will generate a new PO number.
- When shipping, each carton must contain contents for one PO number only.
- Each invoice must include only one PO number; however, a single PO can have multiple invoices.
- **If any item specific information is not correct upon receipt of PO, including item#, case pack, UPC or cost you must contact the Merchandise Manager immediately. Vendor must invoice with the PO cost and Party City will pay the lowest cost between the PO and the invoice. POs with case pack or cost errors must be cancelled and rewritten.**
- Terms and Conditions, contained in Section 9, apply to all POs. The terms and conditions may be supplemented or amended by specific terms and conditions incorporated on a specific PO.
- Vendor must be aware of expected in-store delivery dates, pre-paid or collect, ship to bill to, or other conditions which may vary based on the source of the PO (corporate or franchise). Vendor must execute the terms and conditions (including the ship to location on the PO) on each individual PO.

Changes to PO Information

Changes to a PO can include changes to line item quantity, delivery date, etc. These changes will be reflected through a cancelled PO and issuance of a new PO. If you are unable to fill an everyday PO, contact the Planning & Allocation (P&A) Manager via e-mail for a cancellation or extension, seven days prior to the first ship date for approval. Requested changes to seasonal POs must be communicated in writing to the Merchandise Manager within seven calendar days of the PO request. Verbal agreements are not acceptable. In-store deliveries received after the Vendor Cancellation Date will be subject to penalties as listed in the Reimbursement and Waiver Policy, Section 8.

An authorized Party City representative will submit all Party City initiated PO changes, including cancellations, to the vendor in writing via e-mail. Party City does not send the 860 – PO cancel/change document. Associates in the Merchandising Department and Planning and Allocation Department are authorized to make changes to POs. PO changes include PO cancellation requests. If a line item(s) needs to be changed, the PO will be cancelled and a new PO will be generated.

Party City will not accept shipment of substitute items unless pre-approved in writing by a Merchandise Manager AND followed by a new PO for the substituted items. Substitute items will be subject to penalties as listed in the Reimbursement and Waiver Policy, Section 8.

Section – 1a,c,d (Retail)

UPC Codes

All vendors are required to join GS1 US, formerly known as the Uniform Code Council (UCC), in order for products to be UPC source marked. A scannable UPC must be securely attached or clearly printed on every item or item package. All Halloween costumes must be UPC coded by size (and color where appropriate) for all orders.

Party City recommends you never reuse UPC codes. If unavoidable, you must wait a minimum of 48 months before re-use and notify Party City.

Item UPC Label Guidelines

The correct printing of clear UPC's is of primary importance due to market sensitivity. If an incorrect UPC is printed or the UPC is un-scannable, there will be no initial warning due to the ramifications of the error and chargebacks will be issued as listed in the Reimbursement and Waiver Policy, Section 8.

All barcodes appearing on the label printed for Party City's use shall meet the specifications contained herein.

- White labels are to be used unless specifically directed otherwise
- Print in black
- All UPC's should be in standard UPC-A format and scan at the grade level of "C" or better
- Barcode must be scannable
- Label size needs to be an appropriate size for the item
- One label is to be used unless the item/each come in a box, container, or display. In this case the box, container, or display AND the piece must each have the label.
- Small items that cannot fit a full label should have a butterfly label (same label as used for jewelry items) or hang tag.
- Placement of UPC label should not interfere with operating or product care instructions, as well as any other pertinent product information

Product Samples

Product samples must be sent within 72 hours of a Merchandise Manager's request. **All samples must be clearly marked with the vendor item number, recipient's name, and/or description.** All samples are to be shipped prepaid (regardless of VPA freight terms) to the attention of the requesting Merchandise Manager at Party City or Halloween City using one of the below addresses:

**Party City Corporation
25 Green Pond Road, Suite 1
Rockaway, NJ 07866**

**Halloween City
35901 Veronica
Livonia, MI 48150**

Party City & Halloween City will not pay for samples, shipping charges, import charges, or return samples (select sample returns can be done on a limited basis with the written pre-approval from a Merchandise Manager and call tags or package return label). Product samples, if late, may be subject to penalties as

Section – 1a,c,d (Retail)

listed in the Reimbursement and Waiver Policy, Section 8. In addition, incorrect Plan-O-Gram (POG) dimensions may be subject to penalties as listed in the Reimbursement and Waiver Policy, Section 8.

New Store Merchandise Requirements

Party City continually plans to open new stores. Vendor partner support in opening new stores is critical to our success.

New Store Orders

- Shipping a new store PO indicates the vendor’s agreement to the requirements and terms as outlined in the VSM.
- Our goal for all new store POs is a fill rate of 100%. Purchase orders are generally written far enough in advance to accomplish complete fill.
- If the initial order has a fill rate below 100%, the new store will accept one back order before canceling the PO. Back order must arrive before the end of the arrival window. Fill rate measurements will be calculated on combined shipments tendered during the arrival pick up window.
- Some orders may require small quantities of certain items to be shipped loose in larger boxes. When this happens vendor should ship all like items for a PO in the same box, packed together, to the degree possible. This minimizes damages and improves receiving accuracy at our stores.
- Orders not meeting our fill rate requirements will be subject to penalties as listed in the Reimbursement and Waiver Policy, Section 8.
- New store orders (identified by “NS” as the Dept/buyer code) must NOT deliver earlier than the 1st Delivery Date. This includes orders for new stores, relocations and conversions. Early freight attempted to deliver prior to 1st Delivery date is subjected to delivery refusal with freight returned to vendor or receipt by a non-PC employee and unpaid invoices.

Corporate Everyday and Replenishment/Re-Order

POs will contain the following dates. No back orders are allowed on Everyday and Replenishment/Re-Order POs.

Everyday and Replenishment PO Dates (Party City Only)			
Data Field on Party City Faxed/PDF PO	Definition	Data Fields on EDI 850 PO	850 Code
PO Date	Date PO created by Party City	PO Date	
1st Delivery Date	The date specified by Party City of when the merchandise is expected to be delivered to the Party City location.	Do not deliver before date	064
Vendor Cancel Date	The date specified by Party City when PO will be cancelled if merchandise is not delivered to store by	Cancel if not delivered by	061

- The first date in the arrival window is equivalent to the **“1st In-Store Delivery Date”**. The second date in the arrival window is equivalent to the **“Vendor Cancel if not Delivered by Date”**. It is the vendor’s responsibility to ship or tender orders in a timely manner to ensure product arrives

Section – 1a,c,d (Retail)

within the window. Orders received after the In-Store Date will be subject to chargeback. For delivery reimbursement charges, refer to Reimbursement and Waiver Policy, Section 8.

- Shipments must be consolidated so deliveries to the same location do not ship on consecutive days of a week. Orders not meeting our minimum fill rate or not consolidated will be subject to penalties as listed in the Reimbursement and Waiver Policy, Section 8.
- Vendor must ship replenishment orders within 72 hours of receipt to arrive at the store within the requested delivery window.
- All unshipped individual sku line item order quantities will be "cancelled" off the PO upon receipt of the invoice. This will allow us to reorder unshipped quantities within the next PO cycle. Note: 860 EDI documents will not be sent for this transaction. Do not send more than one invoice per PO over multiple days. If you ship from more than one warehouse, resulting in more than one invoice, you must notify the P&A Manager prior to sending the invoice.

Seasonal and New Store Orders

POs will contain the following dates. Party City will accept back order shipments on Seasonal POs with Merchant approval. New Store POs we will accept one back order shipment only.

Seasonal and New Store Corporate PO Dates (Party City Only)			
Data Field on Party City Faxed/PDF PO	Definition	Data Fields on EDI 850 PO	850 Code
PO Date	Date PO created by Party City	PO Date	
1st Delivery Date	The date specified by Party City of when the merchandise is expected to be delivered to the Party City location.	Do not deliver before date	064
Vendor Cancel Date	The date specified by Party City when PO will be cancelled if merchandise is not delivered to store by	Cancel if not delivered by	061

- All Seasonal shipments must conform to the specified Party City Seasonal-receiving window, unless otherwise noted on the PO. Franchise POs may frequently request a date different than a corporate arrival window. However, if **"ASAP"** or if no date is provided on a franchise PO, use the corporate receiving window. Shipments arriving outside of the window are subject to a reimbursement charge. If you are going to miss the receiving window you must contact your Party City Merchandise Manager or P&A Manager.
- Every new store will have an arrival window for receiving merchandise. The first date in the arrival window is equivalent to the **"1st In-Store Delivery Date"**. The second date in the arrival window is equivalent to the **"Vendor Cancel if not Delivered by Date"**. The arrival window will begin approximately 3 to 4 weeks prior to a new store opening to the public. It is the vendor's responsibility to ship or tender orders in a timely manner to ensure product arrives within the window. Orders received after the In-Store Date (arrival window) will be subject to charge-backs. For delivery reimbursement charges, refer to Reimbursement and Waiver Policy, Section 8.
- Shipments must be consolidated so deliveries to the same location do not ship on consecutive days of a week. Orders not meeting our minimum fill rate will be subject to penalties as listed in the Reimbursement and Waiver Policy, Section 8.
- Vendor must ship in-season replenishment orders within 72 hours of receipt to arrive at the store within the requested in-store delivery window.
- Stores will not accept cash on delivery (COD) shipments unless prior written arrangements are made.

Section – 1a,c,d (Retail)

- Stores, including franchise, are not liable to receive or pay for any merchandise tendered past the arrival window dates.
- For the purposes of calculating vendor minimums, the total cost (or weight) of all POs destined for a single location will be used. For example, the total combined weight or cost of multiple orders with the same ship date will be considered as meeting the vendor minimum as a group, each individual PO will not need to meet minimums.
- In the event the quantity ordered does not match the quantity shipped on a PO, the quantity ordered on a PO will be used to calculate the vendor minimum (backorders will not be required to meet min).

Halloween City Orders

- All Halloween City shipments must conform to the specified arrival date as noted on the PO. If you are going to miss the arrival date, you must contact the Planning & Allocation (P&A) Manager. Shipments arriving after the arrival date are subject to a reimbursement charge.
- Orders not meeting our minimum fill rate will be subject to penalties as listed in the Reimbursement and Waiver Policy, Section (8). In the event the quantity ordered does not match the quantity shipped on a PO, the quantity ordered on a PO will be used to calculate the vendor minimum.
- Halloween City Stores and Distribution Centers will not accept cash on delivery (COD) shipments.

Refer to Reimbursement and Waiver Policy, Section 8, of the VSM for a full listing of reimbursement charges.



Section – 1b (Wholesale)

Merchandise Information

Overview

This section outlines the general guidelines for Party City Holdings, Inc. (PCHI) wholesale consisting of Amscan, Anagram International, and Grasslands Road unless stated otherwise. The guidelines included in this section are Purchase Order (PO) requirements, UPC usage requirements, and new product quoting and approval process.

PO Requirements

Vendor must verify the accuracy of, and adhere to, all data on all POs that are faxed or sent electronically. If you have any questions regarding your PO, contact the appropriate division's Inventory Department.

Purchase Order Confirmation

Currently our Inventory Department sends a number of POs (both everyday and seasonal) to our vendors. An email confirming receipt of all POs must be sent within 48 hours to the appropriate division's Inventory department.

The confirmation must include following:

- PO #
- Item #
- Quantity
- Cost
- Ship date

Purchase Order Shipments

- Vendor must be in receipt of a valid PCHI PO, including a PO number, prior to shipping any product. The PO number must not be modified in any way.
- Terms and Conditions, contained in Section 9, apply to all POs. The terms and conditions may be supplemented or amended by specific terms and conditions incorporated on a specific PO.
- Vendor must be aware of expected ship dates and specific shipping contract instructions (per the Transportation Routing Guide). Vendor must execute against the terms and conditions (including the ship to location on the PO) on each individual PO.

Changes to Vendor Information

Documentation must be e-mailed or faxed, and signed by a senior officer of your company. All changes must be received 14 days prior to their effective date. Changes would include, but are not limited to:

- Change in remittance address
- Change in company name



Section – 1b (Wholesale)

- Change in company ownership: If a change in ownership occurs and the new owner is not currently in our vendor file as an authorized vendor, the company will be considered a new vendor and will be required to complete a New Vendor Package - NVP.
- Change in legal structure
- Bankruptcy Filings
- Change in "Return to Vendor" address
- Change in Shipping address

The letter communicating changes must contain the following information:

- Your company name and Amscan vendor number
- Statement of the change being communicated
- Signature of a senior vendor officer or agent

Written notification of changes must be emailed to the following:

Amscan Inc./Grasslands Road: vendorrelations@amscan.com

Anagram International: vendorrelations@anagramintl.com

Do not send any vendor updates or changes to the Product Managers as they cannot approve or process any vendor changes.

PCHI reserves the right to hold payments pending receipt of this documentation.

Changes to Product Information

Any changes (i.e. to the pricing, product, UPCs, case packs, inner packs, product dimensions, shipping case dimensions, or packaging) must be emailed to the appropriate Product Manager for approval. A copy of the product packaging changes must be emailed to the appropriate wholesale entity below:

Amscan Inc./Grasslands Road: Nettie Frohnhoefer, nthomps@amscan.com

Anagram International: Helen Phillips, hphillips@anagramintl.com

Vendor may be held responsible for additional handling and shipping fees for any changes made on or after the ship date.

Changes to PO Information

Any changes to the Purchase Order ship date needs the approval of the Inventory manager who issued the Purchase Order.

Purchase Order Cancellation

PCHI reserves the right to cancel a Purchase Order or request expedited shipping if the PO ship date is not met at vendor's expense.



Section – 1b (Wholesale)

UPC Usage Requirements

Accurate item information is critical for PCHI to service our customers and effectively manage inventory. A scannable UPC must be securely attached or clearly printed on every item or item package, inner pack and master carton.

New Product Quoting Process

Vendors are required to submit all new product quotes to the PCHI Product Development team on the appropriate standard Product Quote form. (see Appendix for Product Quote form for Amscan and Grasslands Road)

Product Development, Product/Package Approval Process

Depending upon Product Development Team – Please see Section I for Amscan and Anagram International; Section II for Grasslands Road

I. Amscan/Anagram International Product Development Approval Process

In an effort to better facilitate the development and sourcing process a coloring system to guide the vendors through the development/sourcing at different stages has been established. Vendors are required to follow these requirements when making a submission. Unacceptable or inappropriate labeling, quantity, or samples will be rejected and resubmission will be required.

White Tag

At this stage vendors are required to submit preliminary samples close to our design concepts or formats. Samples may be submitted in substitute color, material, size or even construction. All samples must have a white manila tag or with a white label attached with an accompanying quote. The quote must be sent on the Amscan/Anagram International standard template where vendors are required to fill in the necessary columns. Samples processed through the Hong Kong office will have the samples and costs sent to product managers for screening and selection by Amscan. Samples not processed through the Hong Kong office are to go directly to the appropriate product manager in the United States.

In some cases where there is a potential safety hazard, vendor may be requested to submit existing testing report for review. Items including cosmetic or firework power composition require a Material Safety Data Sheet (MSDS) be sent for review prior to sending samples for selection.

Yellow Tag

At this stage product managers will confirm sample and cost with final vendor selection. Artwork will be sent directly to vendors via the FTP site or by Compact Disc, dependent on vendor's request. Upon receipt of the artwork, vendors are to confirm final quote based on the artwork specifications. Vendor must immediately communicate and explain any cost variations. Vendors must follow the mechanical art for both product and package in order to proceed with creation of samples for final approval. It is expected all vendors will submit samples no more than 2 weeks upon receipt of the artwork. Vendors are to label the samples with yellow manila tag or yellow label.

If the Hong Kong office is involved with the development of an item, they will help review the yellow tag samples and confirm the sample matches item specification prior to sending samples to product managers for final approval. Rejected samples will require the vendor to re-submit the sample.



Section – 1b (Wholesale)

During the same time period samples will be requested for Plan O Grams and testing. The Plan O Gram requests are 12 pieces for bulk and 3 sets for packaged items. For testing, the requirement is six pieces; refer to the Quality Assurance section for more information. These samples do not need to be Yellow Tagged but need to be marked for its intended purpose upon sending.

When yellow tag samples are approved by product managers in the U.S. office, an approval/comment sheet will be sent to vendors via email. This document will specify one of the three statuses for the product or package:

- **Approved** – product/package is approved as is and the vendor can proceed with production.
- **Approved With Changes** – the vendor must make the requested changes detailed in the proof sheet and may then proceed with production without first sending a new sample for approval. This is only when time is of the essence and another round of samples/proof sheets will slow production and jeopardize the delivery window.
- **Requires Changes** – the vendor must make the requested changes detailed in the proof sheet and submit another sample for approval. **The product/package is not yet approved for production.**

When the Hong Kong office initiates the development of an item, they will sign and send back to the vendor one piece of an approved sample for vendor to follow for production and inspection reference.

Green Tag

At this stage, vendors are to go into production and are also required to take one full case from the production line for review and send to:

Amscan: the Hong Kong Office
Anagram International: Minneapolis, MN

Vendor is to label the samples with green manila tags or green labels for submission. The green tag samples will be compared against the approved yellow tag samples and checked for any variance that may occur during production stage. For production samples with a variance falling within an acceptable limit, the Hong Kong office will sign and return one unit of a green tag sample to vendors as an inspection reference. If the variance falls beyond the acceptable limit, the U.S. office will provide final determination and advise of the results back to vendors. No initial shipment of an item is allowed without the green tag approval.

Our target is to finalize the testing with pass result prior to initial production. Vendor is obliged to make sure the product meets all US Federal safety regulations. No shipment is allowed without a pass testing report from an approved testing facility (i.e.: MTS or SGS), refer to section 4 Quality Assurance. The only exception to this is for items that do not have a testing protocol and do not need to be tested for compliance with the CSPC. We will advise if an item does not require testing.

Inner Sample

For the initial shipment of an item, one full inner must be sent to the U.S. office to the attention of the appropriate product manager, at the time of production.



Section – 1b (Wholesale)

II. Grasslands Road Product Development Approval Process:

A. Product development, from concept to delivery, is facilitated through the Product Development teams to all vendors, working with the HK office as liaison. Product is approved for design once all specs are met. Each vendor is to work with the Product Development team, Packaging team and HK Merchandiser throughout the entire development process. This may involve repeat sampling until the design is approved. PPS samples will be signed by the HK Merchandiser and approved by the Product Manager and Product Designer. The vendors are to follow the PPS samples as reference to execute the production run. The Product Development teams and HK Merchandiser will address all product execution issues prior to producing the product. As product is approved for packaging once the item is quote approved and all packaging specs have been met.

B. Grasslands Road Packaging Production Approval Process:

Stage 1:

Artwork is sent via FTP or courier to the Hong Kong office to corresponding merchandising manager. The manager reviews artwork for any discrepancies. If changes are needed they will contact the New York office and notify them of any problems. The printed art and CD which contains the digital art, is forwarded to the vendor for production. Once the Vendor receives the art, they have two (2) days to review the art and forward all questions to the packaging department in New York.

Stage 2:

The vendor has three (3) weeks to produce a packaging sample, which is then sent to the Hong Kong office for review. If, at this point there are no major discrepancies, the samples are sent to the New York office for review. If the vendor needs more than the allotted three (3) weeks, notification via e-mail must be made to the New York office within the first week. Once samples are received by the New York office, an approval/comment sheet will be sent to the vendor via e-mail. This document will specify three statuses for the packaging:

- **Approved** – packaging is approved as is and the vendor can proceed with production.
- **Requires Changes** – the vendor must make the requested changes and submit another sample for approval. The packaging is not yet approved for production.
- **Approved with changes** – the vendor must make the requested changes and may proceed with production without first sending a new sample for approval. This is only when time is of the essence and another round of samples will slow production and jeopardize the delivery date. Vendor must send New York office a sample for their records.

Stage 3:

Vendor goes into production, pulls ten (10) samples out of production and sends them to the New York office. The approved sample will become the target for all produced pieces, if the variance between the target and the production sample falls beyond an acceptable range, the New York office will provide final determination and advise of the results back to the vendor.

Our target is to finalize the testing with pass result prior to initial production. Vendor is obliged to make sure the product meets all US Federal safety regulations. No shipment is allowed without a pass testing report from an approved testing facility (i.e.: MTS or SGS), refer to section 4 Quality Assurance. The only exception to this is for items that do not have a testing protocol and do not need to be tested for compliance with the CSPC. We will advise if an item does not require testing.

Sample Costs

PCHI will not pay for samples or any shipping charges.

Section – 2a,c,d (Retail)

Electronic Data Interchange

Overview – Party City (includes Party City, Party America, Party City Canada and Halloween City)

Electronic Data Interchange (EDI), with our trading partners establishes standardization of information for accurate product flow from our trading partners to our customers. It is a standard format for exchanging business data between different companies using AS2 communication for direct connects, networks, such as Value Added Networks or the Internet. The American National Standards Institute (ANSI) formed the Accredited Standards Committee (ASC) X12 to define EDI standards of communication. All Party City EDI transactions are ANSI X12 version 4010.

All trading partners must be capable of exchanging information via Electronic Data Interchange (EDI). All Party City Corporate stores and most Franchise stores will use EDI. Franchise stores will continue to receive paper invoices.

All EDI Guidelines and mapping requirements are available on the Party City Vendor Website at <http://www.partycityvendors.com/>.

There are several EDI software providers who can help provide the tools to transmit data via EDI. Party City does not require a sole source solution, but offers alternatives to facilitate cost-effective electronic trade. For more information, you may contact either Nancy Higgins or Patty Madden who can be reached at the phone numbers or email addresses listed below.

All trading partners must communicate any modifications of their EDI or back office systems to Party City's EDI team, in writing, 60 days before such modifications are implemented. Trading partners must work with Party City's EDI Team to validate all documents affected by modifications. Failure to communicate any modifications may incur reimbursement charges as outlined in this guide. Refer to Section 8, Reimbursement and Waiver Policy.

For EDI requirements you may contact members of the Party City EDI Team:

Nancy Higgins	EDI Specialist	973-453-8641	nhiggins@partycity.com
Patty Madden	EDI Specialist	973-453-8765	pmadden@partycity.com

Benefits

EDI eliminates supply chain inefficiencies by:

- Improving Data Integrity: The automated exchange of information improves data integrity by reducing human error and ensures data is complete, consistent and accurate.
- Reducing Operational Costs: The long-term return on investment, due in part to decreased operational expenditures and misallocated resources, offsets the initial start-up and ongoing costs of EDI.
- Improving Customer and Trading Partner Relations: The electronic transfer of time sensitive documents results in expedient delivery of product to store shelves, improving customer satisfaction and increasing sales.

Section – 2a,c,d (Retail)

Methods of Communication

There are three methods of communication to send and receive EDI data between Party City and our trading partners. There is a short description below of these methods. The trading partner must decide which one is applicable to their business or system capabilities. AS2 is Party City's required method of electronic trading of business documents.

1. Direct Connection - AS2

Direct connection with a trading partner eliminates kilo character charges and the costly expense of subscribing to a VAN. However, direct connection adds responsibilities otherwise covered by a VAN, such as: security to limit system access, and the ability to handle a variety of protocols and transmission rates. AS2 is the required method for direct connection. The trading partner is responsible for their AS2 license fees. Trading partners must provide a current AS2 certificate for communicating using AS2. It is the trading partner's responsibility to provide their updated certificate upon certificate expiration.

2. Value Added Network (VAN)

A Value Added Network (VAN) eliminates the need to interface with each trading partner individually. The transfer of information is analogous to correspondence one might exchange through a post office box or slot. The network accepts messages from all participants and stores them in the appropriate slots, where only the assigned users may access them. A trading partner subscribing to a VAN need only interface with the trading partner's assigned mailbox. A VAN will count kilocharacters per transaction and charge the subscriber (trading partner) for transactions being sent as well as received. **If a trading partner chooses to use a VAN, the trading partner is responsible for all kilocharacter charges for data sent and received.**

3. Internet

A web-based solution generally involves manual or automatic data entry onto a web form provided by a third party. Party City strongly encourages non-EDI capable trading partners to fully evaluate a web-based solution. It is a cost efficient, easy to implement, secure EDI solution minimizing ongoing transactional kilocharacter charges associated with a traditional EDI VAN provider.

Each of the aforementioned communication methods can be integrated with the trading partner's current system or exist as a stand-alone system. *Integrated systems* are able to pass data received into other applications without manual intervention. Reduced manual entry is one of the greatest Returns on Investment (ROI) of EDI. *Stand-alone systems* primarily receive data and require the trading partner to manually enter the data into other applications.

If a trading partner chooses to utilize a VAN or direct connection, software is required to translate the trading partner's internal data into the EDI format and to translate data received from a trading partner. The software also performs editing and control functions to ensure the data meets the ASC X12 specifications. A trading partner may choose to use any of the following translation software options:

- Commercial translation packages
- Core business turnkey application software including EDI translation
- Value Added Networks/service providers

Section – 2a,c,d (Retail)

EDI Mapping Guidelines

The EDI Mapping guidelines, located on our website at <http://www.partycityvendors.com/>, provide the requirements for each EDI transaction set and detail specifications of the data exchanged between Party City and our trading partners. Party City mandates all trading partners follow the published EDI Mapping Guidelines for each of the EDI transaction sets. Deviations from the guidelines are not acceptable. Deviations from the guidelines may result in EDI transmission failure and may incur reimbursement charges as outlined in this guide. Refer to Section 8, Reimbursement and Waiver Policy, for more information.

EDI Transaction Sets

Per the EDI standards, each supported document, as listed below, is given an identifier known as a Transaction Set. For instance, a Purchase Order document is referred to as "PO 850."

Party City requires all trading partners to be able to receive or send the following EDI Transaction Sets:

Outbound/Inbound from Trading Partner's Point of View	EDI Transaction Set Number	Document Description
Inbound	850	Purchase Order
Inbound	864	Text Message
Outbound	856	Advance Ship Notice
Outbound	810	Invoice
Outbound/Inbound	997	Functional Acknowledgement

The following websites provide useful information about EDI and the Standards:

- www.disa.org Data Interchange Standards Association
- www.gs1us.org Uniform Code Council
- www.ansi.org American National Standards Institute

Section – 2a,c,d (Retail)

850 Purchase Order

The 850 transaction set is used to place purchase orders. The transaction set will not be used to convey purchase order changes or purchase order acknowledgment information. The 850 PO transaction set contains all information contained on a hard copy PO. The quantity ordered will always be in selling units of measure. In addition, the 850 PO will contain the terms (payment and shipping) the trading partner must use for the order. Invoicing with terms other than those contained on the 850 (PO) will be subject to reimbursement charges. Invoices and ASN's must reflect selling units of measure as they appear on the Purchase Order. If this is not accurate, the invoices and ASN's will be subject to reimbursement charges. Refer to Section 8, Reimbursement and Waiver Policy section, for more information.

POs are transmitted Monday thru Sunday, between the hours of 5 AM and 2 AM EST. Trading partners are required to transmit a 997 Functional Acknowledgement for all 850s within 24 hours of receipt.

The following are the Data fields for the 850 PO:

850 (PURCHASE ORDER) DATA FIELDS	
Header Fields	Detail Fields
<ul style="list-style-type: none"> • PO Number • Buyer Code (Department Code) • AP Terms • PO Notes - 60 Char. • PO Date • Ship to - Store Name • Ship to - Store Number • Ship to - Ship Address • Ship to - City, State, Zip • Ship Via - usually TRG • Bill to Name and Address • Do not deliver before date – <u>This is NOT the ship date</u> • Cancel if not delivered by date • Vendor Number • Vendor Name • FOB - CC for Collect or PP for Prepaid 	<ul style="list-style-type: none"> • PO Line Number • UPC • Case Pack ID • SKU • Vendor Product Description • Qty Ordered - selling units • UOM • Unit Price - up to 4 decimals • Retail Price • Total Purchase Order Amt

Please note, any issues with your Party City PO in regards to the following should be addressed by a member of the respective Merchandising team within 24 hours of receipt of documents:

- Pricing/Cost
- Vendor Item Number
- Vendor UPC
- Orders not meeting minimums
- Unavailability of product
- Cancelled POs
- Delivery date issues

The EDI team should only be notified if there is an EDI transmission error.

Section – 2a,c,d (Retail)

The Department code is sent on the 850 in the PER Segment. The descriptions for those Department codes are:

Dept Code	Department code description
CSTK	CASE STACK PRESENTATION
36CH	CHINESE NEW YEAR
31	CHRISTMAS
44CH	CHRISTMAS CANDY
36CI	CINCO DE MAYO
22	COMMUNION
55	COSTUME ACCESSORIES
55BK	COSTUME ACCESSORIES BULK
27	COSTUME SHOP
27BK	COSTUME BULK
21	EASTER
44EA	EASTER CANDY
EVERY	EVERYDAY
28	FALL
FEDRP	FRANCHISE STORE INITIATED ED REPLENISHMENT ORDERS
23	GRADUATION
23BK	GRADUATION BULK
26	HALLOWEEN
26BK	HALLOWEEN BULK
44HA	HALLOWEEN CANDY

Dept Code	Department code description
30	HANUKKAH
44HK	HANUKKAH CANDY
WEB	INTERNET STORE
56	MARDI GRAS
56BK	MARDI GRAS BULK
NS	NEW STORES
32	NEW YEARS
36PA	PASSOVER
24	PATRIOTIC
24BK	PATRIOTIC BULK
36PU	PURIM
REPLN	REPLENISH
7	SPRING
20	ST PATRICK'S DAY
25	SUMMER
25BK	SUMMER BULK
18	SUPERBOWL
29	THANKSGIVING
44VA	VAL CANDY
19	VALENTINES

Special Use Buyer Codes			
FEDAY	AMSCAN ONLY - FRANCHISE ED REPL	XBUK	ED BYPASS
FEDSO	AMSCAN ONLY - FRANCHISE SOLIDS REPL	GBUK	ED PROMOTIONS

Section – 2a,c,d (Retail)

864 Text Message

Purpose: This Document contains the format and establishes the data content of the Text Message Transaction Set (864) for use within the context of an Electronic Data Interchange (EDI) environment. The transaction set can be used to provide users with a capability to electronically move messages, contracts, explanations, and other one-time communications. It is the intent of this transaction set to provide electronic communication (messages) for people, not for computer processing. The transaction set's purpose for Party City is to provide communication to the recipient in some human-readable form to relay information regarding Product Safety Requirements. The recipient's network will dictate what capabilities are available for delivery of the information.

ISA	Interchange Control Header
GS	Functional Group Header
ST	Transaction Set Header
BMG	Beginning Segment For Text Message
DTM	Date/Time Reference
N1	Loop Name
N1	Name
REF	Reference Identification
MIT	Loop Message Identification
MIT	Message Identification
MSG	Message Text
SE	Transaction Set Trailer
GE	Functional Group Trailer
IEA	Interchange Control Trailer

Section – 2a,c,d (Retail)

856 Advance Ship Notice

The 856 transaction is used to provide Party City with advance data on the shipments of products so Party City may better plan workloads and receipt processing. The ship notice may be sent no later than the time the shipment leaves the trading partner’s shipping area. The ship notice must reflect exactly the product and quantities by carton being sent on the truck as it leaves the trading partner shipping area. Party City requires one PO be associated with each ASN, however, you may have multiple ASN’s associated to one PO. The ship notice **must arrive electronically before the physical shipment arrives at the store**. Refer to the Packaging and Packing Instructions section 3 for GS1-128 label requirements for the 856 (ASN). Please take note, batching processes may delay receipt of an ASN to Party City. Shipments received without an ASN are subject to penalties as listed in the Reimbursement and Waiver Policy, Section 8. The ship notice does not exceed the scope of the bill of lading (BOL), nor does it replace the bill of lading. All small parcel shipments must contain tracking numbers.

NOTE: All United States vendors shipping to Party City Canada stores will ship goods to the consolidation warehouse address indicated on the Party City Bill To Ship To list for Canadian stores. The ASN carton label will indicate the consolidation warehouse in Box 2 of the carton label, and the mark for address will appear in Box 10 of the carton label.

In order to systematically match an ASN receiving transaction to its corresponding invoice, the Ref SI segment is a mandatory segment used to identify a received carton from a specific ASN shipment to its exact intended invoice. This is particularly useful in situations where there are multiple shipments/invoices against a single PO. The Ref SI segment must be the same for the ASN (856) and the Invoice (810) and must be unique to each shipment.

For example:

ASN Data		
PO #	ASN Carton #	ASN Ref Si
1234567	12340000000000000001	1234567A
1234567	12340000000000000002	1234567A
1234567	12340000000000000003	1234567A
1234567	12340000000000000005	1234567B
1234567	12340000000000000006	1234567B
1234567	12340000000000000007	1234567C
1234567	12340000000000000008	1234567C

Invoice Data	
Invoice #	ASN Ref Si
98766	1234567A
98766	1234567A
98766	1234567A
98777	1234567B
98777	1234567B
98888	1234567C
98888	1234567C

All cartons associated with an ASN must have the Party City approved GS1-128 label that matches the carton ID on the ASN. Missing or incorrect carton labels are subject to significant reimbursement charges as defined in the Reimbursement and Waiver Policy, Section 8.

ASNs must be received and processed by Party City prior to shipment arrival at receiving facility. If trading partner’s ASN has not been acknowledged, trading partner must follow up immediately to ensure the EDI document has been received at Party City prior to shipments arriving at the Party City location.

Section – 2a,c,d (Retail)

The following are the Data Fields on the 856 Advanced Ship Notice (ASN):

856 (ASN) DATA FIELDS	
Header Fields	Detail Fields
<ul style="list-style-type: none"> • Vendor Number • Vendor Name • Shipment Number • Shipment Date • Shipped Date • Carrier Details • FOB Shipment Method of Payment • FOB Description • Ship Point Zip Code • Scheduled Receipt Date • Pro Number or Tracking Number • Bill of Lading Number • Invoice Number - optional • Number of Cartons • Weight • SCAC Code • Ship to Store Number • Ship to Address • PO Number • Shipment to Invoice ID (REF*SI) • PO Date • FOB - CC for Collect or PP for Prepaid 	<ul style="list-style-type: none"> • Carton Number (Pack Level) • Line Number • Vendor Item Number • UPC • QTY – as appears on PO • Unit of Measure – selling unit of measure

Section – 2a,c,d (Retail)

810 Invoices

The 810 Invoice is used for the billing of goods shipped. All Corporate purchase orders received via EDI, must be invoiced using the 810 EDI transaction containing the following information:

The Ref Si segment in the ASN must match the REF SI segment on the Invoice and must be unique to each shipment. Each Invoice will have the Ref SI populated to match to its specific ASN shipment. That Ref SI field identifier should only be used for a PO one time and be included on the ASN and the Invoice. A new Ref SI number will be needed for any subsequent shipments against a PO and included on both the ASN and the Invoice.

All Franchise invoices must be manually sent to the Franchisee.

810 (Invoice) Data Fields	
Header Fields:	Detail Fields
<ul style="list-style-type: none"> • Invoice Date • Invoice number • PO Date • PO Number • Shipment to Invoice ID (REF*SI) • Ship to Name • Ship to Store Number • Vendor Name • Vendor Number • Terms Discount Percent • Terms Discount Due Date • Terms Net Due Date • Terms Description (Exact Description from 850 Document) • Terms Discount Days • Terms Net Days • Invoice Notes • Transaction Set Purpose Code • Date Shipped • FOB Method • FOB Description • Bill of Lading/ PRO Number • SCAC Code 	<ul style="list-style-type: none"> • Line Sequence Number • Quantity – as appears on PO • Selling Unit of Measure (UOM) • Unit Price • Vendor Item Number • UPC • Allowance or Charge Indicator • Allowance Code • Allowance/Charge Amount • Method of Handling • Total Invoice Amount – including charges and allowances • Invoice Amount – before charges and allowances • Transportation Code • Number of Units Shipped • Routing • Weight

NOTE: For United States vendors shipping to the consolidation warehouse for Party City Canada stores, all shipments must be accompanied by a manual invoice in addition to the electronic 810. The manual invoices may either be emailed to buffalo@ameri-connect.com or faxed to 716-892-9213. Manual invoices MUST be emailed at the time of shipment to avoid delays in Canada Customs clearing.

Transmission Errors

When errors are detected on inbound EDI documents, our trading partner will be notified. After notification, our trading partner is required to correct and re-send the documents within 24 hours. Our trading partner must notify Party City the corrected documents have been re-sent.

Section – 2a,c,d (Retail)

997 Functional Acknowledgement

Functional Acknowledgements (FA) are required for each functional group transmitted. The FA must be sent by the receiver of the functional group, to the sender, by the close of the next business day after receipt. The FA transaction provides a positive response informing the sender if the contents of the transmission are syntactically correct. *Failure to transmit acknowledgements within specified time will result in reimbursement charges being assessed in accordance with the Reimbursement and Waiver Policy Section 8.* If there is a problem with a transmission, the vendor must contact the Party City EDI team by close of business on the next business day after receipt of transmission to identify issues if they exist. The FA is not an acknowledgement of any application data such as terms, discounts, SKU or UPC numbers.

Failure to transmit acknowledgements or notify the EDI team of any issues within the specified time may result in reimbursement charges being assessed in accordance with the Reimbursement and Waiver Policy in Section 8.

Getting Started

Exchange of EDI and AS2 information

The first step in setting up the trading partner relationship is the EDI TP Questionnaire that is located on our website at <http://www.partycityvendors.com/>, under the section EDI Specifications and Guidelines. This form must be filled out and sent to the EDI Team at Party City, Nancy Higgins, nhiggins@partycity.com or Patty Madden, pmadden@partycity.com. If EDI is outsourced, please consult your provider when completing the AS2 portion of the form. Please note the AS2 certificate is part of the information exchange.

A test schedule will need to be established to meet the two week requirement for completion of testing AS2 connectivity, 850, 810, 856, and 997 and providing a copy of the GS1-128 label.

A complete system test is required with the trading partner and Party City verifying the accuracy of the exchange of data. This test also determines compliance with any unique conditions that have been mutually agreed upon by the partners.

From a technical standpoint, the purpose of the complete system test is to verify the following capabilities:

- The ability to send and receive transmissions to and from the trading partner
- The translation of documents to and from trading partner
- The ability to process the output from the translation process
- The generation of the Functional Acknowledgment (997)
- GS1-128 Label compliance

The testing process will consist of Party City sending an 850 (PO) to verify the data is correct and the mapping is able to translate the data correctly. The 850 (PO) must be accepted and the 997 Functional Acknowledgement returned to Party City. Additionally, Party City requires each PO/shipment be accompanied by the 856 (ASN) and the 810 (Invoice) EDI documents and the GS1-128 label that would be attached to each carton matching data sent via EDI in the 856 transmission.



Section – 2a,c,d (Retail)

Testing is complete after all parties have agreed to the successful exchange of data and verification of the data and the GS1-128 label. The EDI live date will be then established to trade documents in production.

Once in production, chargebacks for non-compliance will be assessed for failure to transmit any documents via EDI, **in accordance with the Reimbursement and Waiver Policy in Section 8.**

Section - 3a,c (Retail)

Packaging & Packing Instructions

Overview – Party City (includes Party City, Party America, and Halloween City)

As business partners driving mutually beneficial supply chain efficiencies, this section contains detailed instructions on packaging, carton labeling and marking, and shipment documentation for merchandise shipped to Party City. Party City is committed to working with our vendor partners to improve product packaging/handling and to increase automation efforts.

It is expected all vendors will comply with the requirements set forth in this Vendor Standards Manual. Non-compliance will result in reimbursements to Party City for processing expenses incurred due to non-compliance. Reimbursements are outlined in Reimbursement and Waiver Policy, Section 8.

All labels applied directly to product must include a removable adhesive so product is not damaged. Placement of labels should not block the UPC or otherwise interfere with operating or product care instructions, as well as any other pertinent product information. For more information regarding item packaging, see *Item UPC Label Guidelines* within Merchandise Information, Section 1.

Packaging Instructions for Merchandise

In order to expedite the receiving of cartons and maintain a high level of accuracy in processing, the following guidelines have been established:

- Only one PO per carton is permitted.
- Each selling unit must contain a valid, scannable, Universal Product Code (UPC) clearly visible and affixed.
- Carton weight should not exceed 45 pounds, unless the product itself weighs more than 45 pounds. If so, a sticker indicating the product exceeds 45 pounds must be attached and clearly visible.
- Seal shipping cartons with tape or light adhesive. Do not use staples or bands.
- Package merchandise in new sturdy cartons capable of withstanding normal shipping and handling.
- PO should be shipped utilizing the least number of cartons while maintaining shipping container integrity and not incurring additional freight charges.
- Do not use loose fill in shipments such as foam chips, shredded paper or straw like material without obtaining prior written approval from the Party City/Amscan Logistics Department. If approval is obtained, clearly identify on the cases with loose fill, in clear writing, that **"loose fill is contained within"**.
- Location address, including store number, and PO number are to be CLEARLY marked on the outside of each carton. A Party City approved GS1-128 label is required for all DSD shipments for corporate stores.
- When multiple carton shipments are made, cartons are to be marked 1 of X, 2 of X, X of X...
- Packing slip is to be enclosed in or affixed to the lead or last carton. If it is enclosed within a carton, the carton must be clearly labeled indicating the packing slip is enclosed. Clearly labeled is defined as a label with a minimum size of 2" x 3" and lettering of at least a size 22 font. Multiple PO's shipped on the same day must be packed individually.

Section - 3a,c (Retail)

Unless granted advance written approval from the Party City/Amscan Logistics Department, shipments not meeting the minimal requirements may be refused upon delivery and returned to the vendor at the vendor's expense. When shipping small packages consolidate to the largest carton size available to minimize # of cartons shipped. Only master cartons should have the GS1-128 label, containing information for all inner cartons.

CONEG: Packaging Requirement

Manufacturers and suppliers of packaging and packaging components are required by law to furnish a certificate of compliance to customers upon request (refer to the introduction section). This applies only to companies who actually put their products in the package and does not apply to the retailer or the individual consumer. The public and state also have access to these certificates.

Should there be any problems after cartons are received, or there is non-compliance with the above criteria, a redesign will be done to comply. Watch this very carefully so that this process and potential chargebacks can be avoided. Failure to meet the Quality Control guidelines will result in penalties as listed in Reimbursement And Waiver Policy, Section 8 and Terms and Conditions, Section 9.

Traceability

Children's products will need permanent distinguishing marks on the product, to the extent practicable, to identify the manufacturer, location, date of production and other necessary information for all goods manufactured on or after 8/14/09.

Marking/Labeling of Cartons

Party City's EDI Team will oversee the approval of the GS1-128 label. Vendors must follow these guidelines for labeling cartons:

Prior to ASN Certification, vendors must include the following on their labels:

- Store Number
- Purchase Order Number
- Store Name and Address
- When multiple carton shipments are made, cartons are to be marked 1 of X, 2 of X, X of X.
- All master cartons must be clearly marked with a label no smaller than 2" x 3" and no larger than 3" x 4" containing the department description, such as: Halloween, Valentine's Day, Replenishment, Everyday, etc. For example, Halloween merchandise should read, "HALLOWEEN" on the outside of the carton. The font must be no smaller than 48 point font and must fit on the label used.

Upon ASN Certification, vendors are responsible for the following:

Effective for all shipments on the date of ASN certification, carton labels for all Party City shipments must be a 4" x 6" GS1-128 shipping label. Each vendor is responsible for supplying GS1-128 labels (as outlined later in this section). These labels may be made in-house with bar-code software or vendors may outsource this responsibility. Party City reserves the right to make future label changes should it be deemed necessary.

Section - 3a,c (Retail)

ASN Certified vendor labels must include the following:

- All Party City Purchase Order (PO) numbers must not be modified and must be human readable.
- All Party City SKUs must be human readable.
- The quantity must always be human readable. The quantity must reflect the number of selling units. For example, if shipping 24 units of an item, the quantity would be 24. No decimals are used.
- The Party City department number must be human readable. The Department No. is provided on all Party City POs. If unclear of the Department No., contact the Party City Planning and Allocations team to identify the Department No.
- GS1-128 labels must be placed on the lower right hand corner of the longest side of the master carton approximately two inches from the carton edges. There should be no labels on the inner cartons. All ASN information for inner cartons should be contained under the label on the master carton.
- Each carton must only have one GS1-128 label
- When multiple carton shipments are made, cartons are to be marked 1 of X, 2 of X, X of X...
- All merchandise must be clearly marked with the department description, such as: Halloween, Valentine's Day, Replenishment, Everyday, etc. For example, Halloween merchandise should read, "HALLOWEEN" in box 5 of the GS1-128 label. The font must be no smaller than 48 point font and must fit on the label used. Refer to the label format examples in this section for more information. If unclear of the department, contact the Party City Planning and Allocations team.

The department information is sent on an 850 EDI PO in the PER Segment as a Department Code. The descriptions for those Department codes are:

Dept Code	Department code description	Dept Code	Department code description
CSTK	CASE STACK PRESENTATION	30	HANUKKAH
36CH	CHINESE NEW YEAR	44HK	HANUKKAH CANDY
31	CHRISTMAS	WEB	INTERNET STORE
44CH	CHRISTMAS CANDY	56	MARDI GRAS
36CI	CINCO DE MAYO	56BK	MARDI GRAS BULK
22	COMMUNION	NS	NEW STORES
55	COSTUME ACCESSORIES	32	NEW YEARS
55BK	COSTUME ACCESSORIES BULK	36PA	PASSOVER
27	COSTUME SHOP	24	PATRIOTIC
27BK	COSTUME BULK	24BK	PATRIOTIC BULK
21	EASTER	36PU	PURIM
44EA	EASTER CANDY	REPLN	REPLENISH
EVERY	EVERYDAY	7	SPRING
28	FALL	20	ST PATRICK'S DAY
FEDRP	FRANCHISE STORE INITIATED ED REPLENISHMENT ORDERS	25	SUMMER
23	GRADUATION	25BK	SUMMER BULK
23BK	GRADUATION BULK	18	SUPERBOWL
26	HALLOWEEN	29	THANKSGIVING
26BK	HALLOWEEN BULK	44VA	VAL CANDY
44HA	HALLOWEEN CANDY	19	VALENTINES
Special Use Buyer Codes			
FEDAY	AMSCAN ONLY - FRANCHISE ED REPL	XBUK	ED BYPASS
FEDSO	AMSCAN ONLY - FRANCHISE SOLIDS REPL	GBUK	ED PROMOTIONS

Section - 3a,c (Retail)



Label Format

Labels must include the following information and must be in the format specified by Party City. Remember to include the field identifier numbers when bar-coding.

BOX 1	FROM	Vendor name and address where the merchandise ships from
BOX 2	TO	"Party City", store number, address and zip code that merchandise is being sent to or the destination as specified on the PO. *May be waived for HC. This will be communicated and documented.
BOX 3	SHIP TO POST	Ship to zip code must be human readable and bar-coded.
BOX 4	CARRIER INFORMATION	SCAC code and one of the following: Tracking number, PRO number, Bill of Lading (BOL) number. *May be waived for HC. This will be communicated and documented.
BOX 5	DENOTE DEPARTMENT DESCRIPTION	The vendor must input the department description. Department Code is obtained from the PO.
BOX 6	DEPARTMENT	Party City department in which the vendor product is categorized. Department information is obtained from PO.
BOX 7	SKU UPC DESCRIPTION OR MIXED	The Party City SKU number must be human readable. Should also contain UPC and the Party City Item description. If more than one SKU per carton, the SKU should read "MIXED", UPC should be blank, and the Description should be blank.
BOX 8	PO NUMBER PARTY CITY VENDOR NUMBER	The PO# appearing on the Party City PO. PO# must be human readable. The vendor number is the Party City assigned vendor number.
BOX 9	QUANTITY	The quantity must be human readable. The quantity is the total number of selling units in a carton. Field must be blank if more than one SKU in carton.
BOX 10	MARKED FOR	Final destination of the merchandise. The store number is four digits in length, must be human readable. Must use the full address of the final destination. Please use larger font for store no. (48). *May be waived for HC. This will be communicated and documented.
BOX 11	SSCC-18 STANDARD GS1-128 BAR CODE	Carton serial number, which must be unique and never repeated on any cartons or shipments. This must be human readable and bar-coded for a total of 20 digits. "00" is the application identifier. Position 18- must use "0" to indicate the shipping container is a case or carton. Position 17 – "0" indicates your company has a unique number assigned by the UCC. Positions 16 through 11 - indicate the unique number assigned to your company by the UCC. Positions 10 through 2 – indicate the sequential numbering of cartons, unique for each carton and not repeated for 2 years. Position 1 – Modulo 10 check digit.

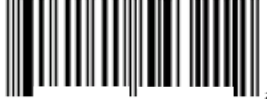

Section - 3a,c (Retail)

Party City GS1-128 Label Format
Carton Label Requirements
Single SKU Label Format
For Direct to Store Shipments

Box 1	From: XYZ Party Supply 123 Party Place Anytown, NJ 07866	To: Party City Store #0012 321 Main St. Anytown, NJ 07866	Box 2
Box 3	07866 	Carrier Information	Box 4
Box 5	<h1>Halloween</h1>		
Box 6	Dept. 26	SKU: 12345	Box 7
Box 8	PO #: 123456789	UPC: 021300147097	
	Vendor #: 111	Description: Party City Item	
Box 9	Quantity 0024	#0012 321 Main St Anytown, NJ 07866	Box 10
	 (00) 0 06 14141 123456789 0		Box 11

Section - 3a,c (Retail)



Party City GS1-128 Label Format
Carton Label Requirements
Multi - SKU Label Format
For Direct to Store Shipments

Box 1	From: XYZ Party Supply 123 Party Place Anytown, NJ 07866	To: Party City Store #0012 321 Main St. Anytown, NJ 07866	Box 2
Box 3	07866 	Carrier Information	Box 4
Box 5	<h1>Halloween</h1>		
Box 6	Dept. 26	SKU: MIXED	Box 7
Box 8	PO #: 123456789	UPC:	
	Vendor #: 111	Description:	
Box 9	Quantity	#0012 321 Main St Anytown, NJ 07866	Box 10
	 (00) 0 06 14141 123456789 0		Box 11

Section - 3a,c (Retail)



**Party City GS1-128 Label Format
Carton Label Requirements**

Single SKU Label Format
For "Ship To - Marked For" Shipments
(By-Pass or Consolidation)

Box 1	From: XYZ Party Supply 123 Party Place Anytown, NJ 07866	To: Party City Store #0999 123 State St. Anytown, PA 06543	Box 2
Box 3	06543 	Carrier Information	Box 4
Box 5	<h1>Halloween</h1>		
Box 6	Dept. 26	SKU: 12345	Box 7
Box 8	PO #: 123456789	UPC: 021300147097	
	Vendor #: 111	Description: Party City Item	Box 10
Box 9	Quantity 24	#0012 321 Main St Anytown, NJ 07866	
	 (00) 0 06 14141 123456789 0		Box 11

Section - 3a,c (Retail)

Party City GS1-128 Label Format
Carton Label Requirements
Multi-SKU Label Format
For "Ship To - Marked For" Shipments
(BY-Pass or Consolidation)

Box 1	From: XYZ Party Supply 123 Party Place Anytown, NJ 07866	To: Party City Store #0999 321 Main St. Anytown, NJ 07866	Box 2
Box 3	06543 	Carrier Information	Box 4
Box 5	Halloween		
Box 6	Dept. 26	SKU: MIXED	Box 7
Box 8	PO #: 123456789	UPC:	
	Vendor #: 111	Description:	
Box 9	Quantity	#0012 321 Main St Anytown, NJ 07866	Box 10
	 (00) 0 06 14141 123456789 0		Box 11

Section - 3a,c (Retail)

Packing Slips

Party City requires a packing slip for all shipments. Only 1 packing slip per PO # shipped. The packing slip must contain the following information:

- Party City PO number
- Party City Store Number
- Number of cartons
- Item descriptions, SKU # (only if EDI certified)
- Item quantities
- Grand total units

For common carrier shipments, insert packing slips into a removable pouch and place on the outside of a "Lead Carton" (1 of X) or "Last Carton" (X of X) for each shipment. Indicate "Lead Carton" on carton or place in a "Packing Slip Enclosed" preprinted pouch. In addition, the packing slip can be placed inside a "Lead Carton" or "Last Carton" where the carton is clearly labeled "Packing Slip Enclosed" on the outside of the carton. The carton containing the packing slip must be placed on the top layer of the pallet with the clearly marked "Packing Slip Enclosed" area facing out. Each Bill of Lading must be marked with the actual carton count.

For parcel shipments, the carton labeled 1 of X is the "Lead Carton," and the carton labeled X of X is the "Last Carton." Follow the instructions described above for packing slip placement.



Section – 3b (Wholesale)

Packaging & Packing Instructions

Overview

This section outlines the packaging and packing requirements for Party City Holdings Inc (PCHI) wholesale consisting of Amscan, Anagram International, and Grasslands Road unless stated otherwise.

TOPS and its importance

Packaging is designed using Total Optimization Packaging Software (TOPS). Every new product is put through the TOPS program to determine the most efficient use of space (dimensions), as well as effective carton weight. For existing products, the inner pack dimensions and weight may be used to develop new master carton packaging. The program will generate several inner and master carton packaging options and pallet designs based on desired parameters.

Five key reasons why it is important for you to follow the requested packaging:

1. If the master carton is too large, it will not fit into our storage racks. The inners will have to be hand-stacked or the master will have to be cut in half in order to fit on the shelves. This can cause damage to the product. Our storage racks have an opening of 17". For this reason, the width of the master carton must be under 17".
2. If the flap orientation is not as requested, the side of the master carton will be cut open in order to remove the inners in the storage racks, which can lead to damaged product.
3. Master carton weight cannot be above 40 lbs. For safety and efficiency, the weight and inner carton quantity may need to be reduced. **Please contact the TOPS Engineer, Nettie Frohnhoefer, before purchasing the master cartons if the weight will exceed 40 lbs.**
4. Inner pack quantity must be as requested.
5. Packaging too large for the product may result in crushed cartons when stacked which in turn will cause wasted space, higher freight costs, and possibly damages.

For most products, only one each is available for packaging design. In this case, we will generate estimated packaging dimensions and weights. This packaging is developed as a guideline to illustrate our desired inner pack quantity and orientation in the master carton. Flap orientation of the master carton is important. A 1" variance in any dimension on the master carton is acceptable. Penalties will be assessed with variances over 1" if the dimensions are not approved by warehouse management. If your packaging is not within this tolerance, please contact the TOPS Engineer with your suggested dimensions. Your recommendations will be evaluated for acceptance or you will be instructed to re-design the master carton based on your inner pack dimensions. **These dimensions must be approved by Amscan prior to purchasing packaging materials so that potential changes can be made to the packaging starting with the first purchase order.** In any case where there is differing information on the Amscan purchase order, please contact your product manager and the TOPS Engineer to confirm the correct quantities.

Pallet Loads – Applies to Domestic shipments only

Palletized loads are not to exceed the maximum height of 54" including the pallet. Any items requiring pallet stacks higher than 54" must get approval from the Amscan Distribution Center Receiving Manager, Bill Bennett, prior to shipping. Only GMA standard wooden pallets 40" x 48" grade B or higher should be used. TOPS shows recommended pallet designs based on calculated master carton dimensions. Please refer to this pallet design to ensure proper pallet configuration.



Section – 3b (Wholesale)

A variance of 1" in one or more dimensions of the master carton may not allow for the desired pallet configuration. Please notify the Tops Engineer if you cannot fit at least the specified master carton quantity on a pallet. There should be no overhang front to back; there can be some overhang side-to-side but no more than 1" unless otherwise approved. All pallet loads should be secured and wrapped appropriately for the product to arrive at the Distribution Center intact. Double stacked pallet loads are acceptable for domestic shipments, unless damages are occurring. Amscan may exercise the right to require vendors to single stack, add corner supports, slip-sheets, or other securing methods for future shipments; this will minimize your damages and enable us to lessen the double handling of product. In the event shipments arrive at the DC and are not compliant with Pallet load specifications, damaged or require restacking, vendors will be charged back for additional handling and/or the shipment refused.

Existing product without TOPS specifications

On any other product you are shipping to us, please continue shipping as you have been. Any changes you wish to make on existing product must be communicated to and approved by Amscan.

We are reviewing all current product in our distribution center. Any item which is an issue due to weight or size causing us undue material handling may be reviewed and reassessed. In that case, a TOPS form will be forwarded to you.

We are charging you as our business partner, with the responsibility of understanding and complying with Amscan's TOPS program on all new product moving forward. This pertains to all product sold to Amscan.

TOPS for Grasslands Road items

Due the fragile nature of Grasslands Road items, these will not go through the TOPS program. The vendor can make a more accurate estimate than the TOPS Engineer of how much additional packing material will be needed. The number of inners per master that the vendor recommends when quoting will be used when the purchase orders are placed. Once the drop test is performed, the vendor should email the master carton dimensions and weights to the TOPS Engineer. Once they are approved, the vendor should proceed with ordering materials. **Packaging materials should not be purchased until the dimensions have been approved.** If the dimensions are not approved, the TOPS Engineer will make suggestions for changes to the inners per master so that the master dimensions will fall within Amscan requirements. Once these changes are agreed to by the product manager and the vendor, a revised PO can be issued. After the dimensions are approved, if any changes need to be made, the vendor must inform the TOPS Engineer, relevant product manager, and merchandiser.



Section – 3b (Wholesale)

How to read a TOPS form

Once a TOPS form has been created, it will be emailed to you by the TOPS Engineer. You will need to review the TOPS form and advise the TOPS Engineer that you agree to the packing that is shown in the form. If you do not agree to the packing method, contact the TOPS Engineer to resolve any problems before the item is shipped to avoid any penalties.

TOPS examples are shown on the next three pages. The first page is in English units of measure (inches and pounds) and the second page is in Metric units of measure (millimeters and kilograms).

Section **A** shows the packing of the eaches in the inner carton and identifies the number of eaches per inner. The dimensions are also listed. In the example, the eaches are packed in a polybag inner. If the eaches are in a corrugate inner box, this will be visible in the picture.

Section **B** shows the packing of the inners in the master carton and lists the number of inners per master. The dimensions are also listed. The master carton will always be shown as corrugate carton. Please note the orientation of the inners in the master.

Section **C** is only for vendors shipping product to us on pallets and for warehouse use. All foreign vendors can disregard this section.

Section **D** is a summary of the carton information. "Carton (OD)" is the measurements of inner carton. "Shipper (OD)" is the measurements of the master carton. (Ln = Length, Wd=Width, Ht=Height, and Grs=Gross Weight)

Notes: Any additional packing notes are listed in this section. If the inner is a polybag, this will be noted in this section. This section will list all of the items that this form applies to.

The third page shows an example where the number of eaches in the inner is equal to the number of eaches in the master. Since there are no inner cartons, only the master carton is shown. This carton should have a master carton label with a 300 series (inner carton) barcode.

Please contact the appropriate TOPS Engineer for any questions concerning packing requirements that are not listed in the TOPS form.

Amscan TOPS Engineer

Nettie Frohnhoefer
E-mail : tops@amscan.com
Phone: 845-572-2151

Amscan TOPS Manager

Paula Kochon
E-mail : pkochon@amscan.com
Phone: 845-469-9116 ext. 2133

Anagram International TOPS Engineer

Cory Evans
E-Mail: cevens@anagramintl.com
Phone: 952-949-5692

Anagram International TOPS Manager

Tina Outlaw
E-Mail: toutlaw@anagramintl.com
Phone: 952-949-5636

EXAMPLE OF ACTUAL TOPS FORMS

	<p>123456-PARTY ITEM</p>	<p>Date Printed : 1/27/2012 Last Saved : 1/27/2012</p>																																																																																
<p>Tops Engineering</p>																																																																																		
<p>A.</p>	<p>B.</p>																																																																																	
<p>C.</p>	<p>D.</p> <table border="1" style="width: 100%; border-collapse: collapse;"> <thead> <tr> <th></th> <th>Carton (OD)</th> <th>Shipper (OD)</th> <th>Unit Load (Incl. Pal)</th> </tr> </thead> <tbody> <tr> <td>GMA (Notched) 48.000x40.000x5.000</td> <td></td> <td></td> <td></td> </tr> <tr> <td>Ln:</td> <td>7.000 in</td> <td>14.500 in</td> <td>48.000 in</td> </tr> <tr> <td>Wd:</td> <td>5.000 in</td> <td>10.500 in</td> <td>40.000 in</td> </tr> <tr> <td>Ht:</td> <td>6.000 in</td> <td>18.750 in</td> <td>48.500 in</td> </tr> <tr> <td>Net:</td> <td>0.000 lb</td> <td>0.000 lb</td> <td>0.000 lb</td> </tr> <tr> <td>Grs:</td> <td>2.643 lb</td> <td>32.728 lb</td> <td>948.646 lb</td> </tr> <tr> <td>Cube:</td> <td>210.000 in³</td> <td>1.652 ft³</td> <td>53.889 ft³</td> </tr> <tr> <td></td> <td>Height Vert</td> <td>Height Vert</td> <td></td> </tr> <tr> <td>Prod.Vol:</td> <td>0.000 in³</td> <td>0.000 in³</td> <td>0.000 ft³</td> </tr> <tr> <td>Carton:</td> <td></td> <td>12</td> <td>324</td> </tr> <tr> <td>Shipper:</td> <td></td> <td></td> <td>27</td> </tr> <tr> <td>Area Efficiency:</td> <td></td> <td>96.9 %</td> <td>92.3 %</td> </tr> <tr> <td>Cubic Efficiency:</td> <td></td> <td>96.2 %</td> <td>81.9 %</td> </tr> <tr> <td>Prod.Eff:</td> <td>0.0 %</td> <td>0.0 %</td> <td>0.0 %</td> </tr> <tr> <td>Cases per layer:</td> <td></td> <td></td> <td>9</td> </tr> <tr> <td>Layers/load:</td> <td></td> <td></td> <td>3</td> </tr> <tr> <td>Pattern:</td> <td></td> <td>2x2x3</td> <td>Triblock</td> </tr> <tr> <td>Max UL High:</td> <td></td> <td></td> <td>4</td> </tr> <tr> <td>Clamp Direction:</td> <td></td> <td></td> <td>N/A</td> </tr> </tbody> </table>			Carton (OD)	Shipper (OD)	Unit Load (Incl. Pal)	GMA (Notched) 48.000x40.000x5.000				Ln:	7.000 in	14.500 in	48.000 in	Wd:	5.000 in	10.500 in	40.000 in	Ht:	6.000 in	18.750 in	48.500 in	Net:	0.000 lb	0.000 lb	0.000 lb	Grs:	2.643 lb	32.728 lb	948.646 lb	Cube:	210.000 in ³	1.652 ft ³	53.889 ft ³		Height Vert	Height Vert		Prod.Vol:	0.000 in ³	0.000 in ³	0.000 ft ³	Carton:		12	324	Shipper:			27	Area Efficiency:		96.9 %	92.3 %	Cubic Efficiency:		96.2 %	81.9 %	Prod.Eff:	0.0 %	0.0 %	0.0 %	Cases per layer:			9	Layers/load:			3	Pattern:		2x2x3	Triblock	Max UL High:			4	Clamp Direction:			N/A
	Carton (OD)	Shipper (OD)	Unit Load (Incl. Pal)																																																																															
GMA (Notched) 48.000x40.000x5.000																																																																																		
Ln:	7.000 in	14.500 in	48.000 in																																																																															
Wd:	5.000 in	10.500 in	40.000 in																																																																															
Ht:	6.000 in	18.750 in	48.500 in																																																																															
Net:	0.000 lb	0.000 lb	0.000 lb																																																																															
Grs:	2.643 lb	32.728 lb	948.646 lb																																																																															
Cube:	210.000 in ³	1.652 ft ³	53.889 ft ³																																																																															
	Height Vert	Height Vert																																																																																
Prod.Vol:	0.000 in ³	0.000 in ³	0.000 ft ³																																																																															
Carton:		12	324																																																																															
Shipper:			27																																																																															
Area Efficiency:		96.9 %	92.3 %																																																																															
Cubic Efficiency:		96.2 %	81.9 %																																																																															
Prod.Eff:	0.0 %	0.0 %	0.0 %																																																																															
Cases per layer:			9																																																																															
Layers/load:			3																																																																															
Pattern:		2x2x3	Triblock																																																																															
Max UL High:			4																																																																															
Clamp Direction:			N/A																																																																															
<p>Notes: Inner is a 3 mil polyethylene bag. Close and securely tape the polybag to prevent the eaches from falling out. Master carton must be able to pass a 200 lbs/in² bursting test or a 48 lbs per inch edge crush test. All measurements are approximate.</p>																																																																																		
<p>NETTIE FROHNHOEFER</p>																																																																																		

Section – 3b (Wholesale)

Tops Engineering

123456-PARTY ITEM

Date Printed : 1/27/2012
Last Saved : 1/27/2012

A.

6 EACHES PER INNER POLYBAG

B.

12 INNERS PER MASTER CARTON

C.

D.

GMA (Notched) 1219x1016x127

	Carton (OD)	Shipper (OD)	UnitLoad (Incl. Pal)
Ln:	178 mm	368 mm	1219 mm
Wd:	127 mm	267 mm	1016 mm
Ht:	152 mm	476 mm	1232 mm
Net:	0 kg	0 kg	0 kg
Gr:	1 kg	15 kg	430 kg
Cube:	3 l	0 m3	2 m3
	Height Vert	Height Vert	
Prod.Vol:	0 l	0 l	0 m3
Carton:		12	324
Shipper:			27
Area Efficiency:		96.9 %	92.3 %
Cubic Efficiency:		96.2 %	81.9 %
Prod.Eff:	0.0 %	0.0 %	0.0 %
Cases per layer:			9
Layers/load:			3
Pattern:		2x2x3	Triblock
Max UL High:			4
Clamp Direction:			N/A

Notes: Inner is a 3 mil polyethylene bag. Close and securely tape the polybag to prevent the eaches from falling out. Master carton must be able to pass a 200 lbs/in² bursting test or a 48 lbs per inch edge crush test. All measurements are approximate.

NETTIE FROHNHOEFER



Tops Engineering

123456-PARTY ITEM

Date Printed : 1/27/2012

Last Saved : 1/27/2012

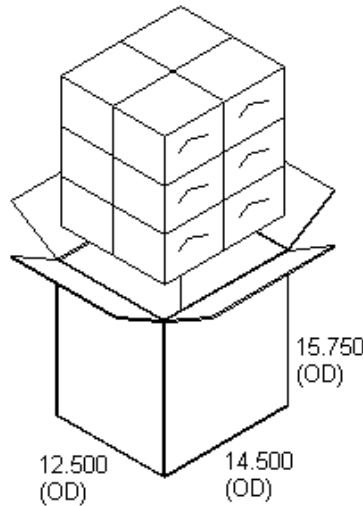

12 EACHES PER INNER, INNER CARTON = MASTER CARTON

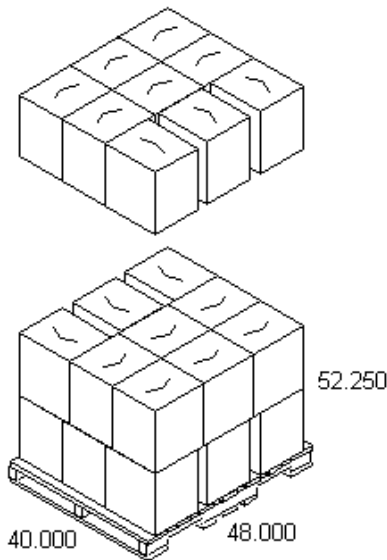

GMA (Notched) 48.000x40.000x5.000

	Carton (OD)	Shipper (OD)	Unit Load (Incl. Pal)
Ln:	7.000 in	14.500 in	48.000 in
Wd:	5.000 in	12.500 in	40.000 in
Ht:	6.000 in	15.750 in	52.250 in
Net:	0.000 oz	0.000 lb	0.000 lb
Gr:	16.000 oz	13.059 lb	417.603 lb
Cube:	210.000 in ³	1.652 ft ³	58.056 ft ³
	Width Vert	Height Vert	
Prod. Vol:	0.000 in ³	0.000 in ³	0.000 ft ³
Carton:		12	324
Shipper:			27
Area Efficiency:		97.2 %	85.0 %
Cubic Efficiency:		96.4 %	81.9 %
Prod. Eff:	0.0 %	0.0 %	0.0 %
Cases per layer:			9
Layers/load:			3
Pattern:		2x2x3	Interlock
Max UL High:			4
Clamp Direction:			N/A

Notes: Master carton must be a sturdy, reshippable, double walled corrugate. Master carton must be able to pass a 200 lbs/in² bursting test or a 32 lbs per inch edge crush test. All measurements are approximate.

Quality Control guidelines

In addition to our TOPS Program, Quality Control is another issue of paramount importance.

The following are Quality Control guidelines all Vendors must adhere to. While many of these guidelines seem like good, practical common sense, the daily abuse encountered at all of Amscan Distribution Centers warrants the reiteration of the guidelines below. Failure to comply with any of the below requirements will result in chargebacks (see section 8 Reimbursement and Waiver Policy).

Labeling Requirements

- Labeling is checked on the master, inner, and eaches.
- Julian Date Coding is required on the master carton, inner pack and eaches.
- Labeling for master carton, inner pack and eaches must all have a scannable bar code.
- Each label has its own set of specifications. Refer to the separate sections for label requirements.

UPC/Bar Code Requirements

- UPC's are checked for scannability and for the correct readable digits printed below the bar (human readable).
- Bar Codes are scanned for correctness. All bar codes must scan and verify against ANSI standards with a grade of "C" or better.
- It is the vendor's responsibility to ensure correct scannability of all bar coding.
- For the master carton label bar code, the minimum bar code height is 1.5". The bar code must be printed on the label to allow at least 1/2" white zone around the entire perimeter of the bar code.

Packaging

- Packaging is checked to make sure that inners per master, eaches per inner, and eaches per master are correct according to Amscan's specifications.
- Packaging is checked to make sure correct packaging is used for each product if required (example: bubble wrap, corrugated inserts, special packaging if required / necessary).
- If polybags are to be used for inners, they must be a minimum of a 3 mil polyethylene bag and it must be securely sealed shut so the product cannot fall out.
- No strapping to be used on master cartons (do not strap 2 master cartons together).
- No staples to be used on master cartons or on inner cartons.
- No sub masters are ever to be used.
- If the inner is a display carton, securely tape the display carton closed on three sides.
- **Inner cartons must be securely taped closed.**
- Cartons are not to be cut down without approval from the warehouse.
- **Any additional packaging material used to protect the product must be inside of the inner cartons. It cannot be surrounding the inner cartons in the master cartons.**

Quality/Artwork

- Product is checked against the approved sample by the Product Manager or catalog copy.
- Item packaging is checked for new artwork and color schemes.
- Any quality defects are the responsibility of the maker. Chargebacks will be issued for any product which requires re-working or replacement.

Section – 3b (Wholesale)

Dimensions & Weight

- Measurements and weights are checked by the Cubiscan team and must meet all Amscan and TOPS requirements.
- No master carton should exceed the weight of 40 lbs. You must have approval from warehouse management prior to shipment being made if the weight of the master carton exceeds 40lbs.
- **MINIMUM MASTER CARTON SIZE:** 12" Length x 12" Width x 12" Height (prior approval is needed for any master carton deviating from the minimum carton size)
- **MAXIMUM MASTER CARTON SIZE:** 20" Length x 17" Width x 16" Height. (prior approval is needed for any master carton deviating from the maximum carton size)
- Contact the TOPS Engineer, Nettie Frohnhoefer, for approval for dimensions and weights that deviate from these requirements.
- Final weights and dimensions of master cartons must be supplied to Amscan no later than 2 weeks prior to shipment.
- For items where the number of pieces in the inner is equal to the number of pieces in the master (**full case items**), the dimension requirements do not apply.

Master Carton

- Carton should always be made of durable, double-walled, shippable corrugate.
- Masters weighing up to 20 lbs, the minimum requirements are a 200 lbs per square inch (14.1 kg per square cm) bursting test or a 32 lbs per inch (5.7 kg per cm width) edge crush test.
- Masters weighing over 20 lbs, the minimum requirements are a 200 lbs per square inch (14.1kg per square cm) bursting test or a 48 lbs per inch (8.6 kg per cm width) edge crush test.
- You may not mix SKUs in a Master.
- **MASTER CARTON PACKS:** We will not accept 2 inners per master. These items should either be changed to 3 or more inners per master or the inner should equal the master depending on the size of the item.
- There should be no excess space in the master carton when the cartons are packed.

CONEG: Packaging Requirement

Manufacturers and suppliers of packaging and packaging components are required by law to furnish a certificate of compliance to customers upon request (refer to the introduction section). This applies only to companies who actually put their products in the package and does not apply to the retailer or the individual consumer. The public and state also have access to these certificates.

Should there be any problems after cartons are received, or there is non-compliance with the above criteria, a redesign will be done to comply. Watch this very carefully so that this process and potential chargebacks can be avoided. Failure to meet the Quality Control guidelines will result in penalties as listed in Section 8 (Reimbursement And Waiver Policy) and Section 9 (Terms and Conditions).

Traceability

Children's products will need permanent distinguishing marks on the product, to the extent practicable, to identify the manufacturer, location, date of production and other necessary information for all goods manufactured on or after 8/14/09.



Section – 3b (Wholesale)

Amscan Labels

Master Carton Labels

Amscan uses a sophisticated warehouse management system. The labeling of all master cartons according to the following guidelines will assist in maintaining accurate inventory levels at our distribution centers and will make it easier to service our customers. All efforts to meet these specifications must be made. Any questions regarding this should be handled with Kim Aldrich at fax number: 845-572-2178.

Master Carton Label Guidelines

- White labels with Black print are to be used unless specifically directed otherwise.
- Bar Code is interleaved 2 of 5, 14 digits or standard subset, 6 symbology.
- Bar Code must be scannable.
- Width of the narrow bar and space between bars to be a minimum of .015" (or 15mil).
- The width of the wide bar and space must be twice as large as the narrow bar and space.
- Minimum bar code height is 1.5".
- The bar code must be printed on the label to allow at least 1/2" white zone around the entire perimeter of the bar code.
- Label Size: 6" x 4" minimum; 6" x 6" maximum. (If label size is larger than the master carton, smaller labels may be used upon approval.)
- Use 2 labels per carton on adjacent sides
- Do not place label over sealing tape where box flaps join.
- Labels MUST be in type, NO handwritten labels
- Do not print the information directly onto the carton. A label must be used.
- The font used must be a minimum of 14 pt font for everything except the Amscan locations, which must be at least 9 pt font.
- The following information must be on all Master Carton labels:
 - Amscan Item Number
 - Unit of Measure Conversion: (This information must match the quantities listed on the Amscan purchase order)
 - EA/IP = Eaches per Inner pack (retail units per selling unit)
 - IP/MC = Inner pack per Master Carton (selling units per purchasing unit)
 - Total number of eaches in the Master Carton
 - Amscan Item Description
 - Amscan Purchase Order Number
 - Your Amscan Vendor Number
 - Country of Origin
 - Amscan name and locations
 - Amscan Inc.
 - Elmsford, NY 10523 USA
 - Toronto, ON, Canada M3J 2E8
 - England, Milton, Keynes MK10 0DA
 - The 14 digit interleaved 2 of 5 Bar Code with the horizontal lines all printed.
 - Human readable digits of the Bar Code printed directly underneath bars
 - Production code printed below the Bar Code – (Julian Date Code) Example - February 21, 2013 to read as follows 13052.

Master Carton Label Placement

The location of the Interleaved 2 of 5 (SCC 14) Bar Code on each side is as follows:

- Bottom of the bars must be be 1.25" (+/-0.25") from the bottom of the carton.
- The clear areas on the sides of the bar code must be at least 0.75" from both edges of the carton.
- Interleaved 2 of 5 (SCC-14)
- See diagrams below for label placement

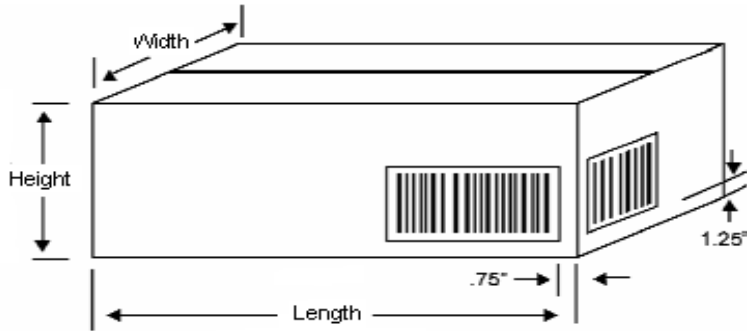

Master Carton Label Example

670585
12 EA X 8 IP = 96 EA/MC
DEC SWIRL VALUE BDAY FEVER
PO# 123456 **VENDOR # 505**
MADE IN CHINA **AMSCAN Inc.** Elmsford NY 10523 USA
Toronto, ON, Canada M3J 2E8
England Milton Keynes MK10 0DA



50013051313239
13052

*** 500-Series bar code denotes this carton is a Master.**



Section – 3b (Wholesale)

When the number of pieces in an inner carton equals the number of pieces in the master carton or the distribution will be done only by the complete Master Carton, the barcode should be the 300 series with all master carton information as shown on the example below.

469042
16 EA X 1 IP = 16 EA/MC
DEC LANTERN GID FIREFLY ITGXII
PO# 173793 VENDOR # 837
MADE IN CHINA AMSCAN Inc. Elmsford NY 10523 USA
Toronto, ON, Canada M3J 2E8
England Milton Keynes MK10 0DA



30013051306848
13052

Section – 3b (Wholesale)

The master carton label for a Kit is shown in the example below. The unit of measure should include KIT instead of EA. A KIT is several different each UPCs under one item number.



*** 500-Series bar code denotes this carton is a Master. Kits can also have 1 IP/MC and have a 300-series bar code on the master label.**

Inner Carton Labels

Inner Carton Label Guidelines

- White labels with Black print are to be used unless specifically directed otherwise
- Bar Code must be scannable
- Label Size: 4 5/8" Wide x 3 1/2" High (If label size is larger than the inner carton, smaller labels may be used upon approval.)
- Place label on the inner carton so that the inner label is showing when the master carton is opened. If the side that is facing out when the master carton is opened is too small to fit the label, the largest size may be used.
- The following information must appear on the label:
 - Amscan Item Number
 - Number of packages in the inner
 - Amscan product description
 - Amscan Purchase Order Number
 - Country of Origin
 - Your Amscan Vendor Number
 - Amscan name and locations:

Section – 3b (Wholesale)

Amscan Inc.

- Elmsford, NY 10523 USA
 - Toronto, ON, Canada M3J 2E8
 - England, Milton, Keynes MK10 0DA
- Bar Code, interleaved 2 of 5, 14 digits
 - Human readable digits of the Bar Code printed directly underneath bars
 - Production code printed below the Bar Code – (Julian Date Code) February 21, 2013 to read as follows 13052.

Inner Carton Label Placement

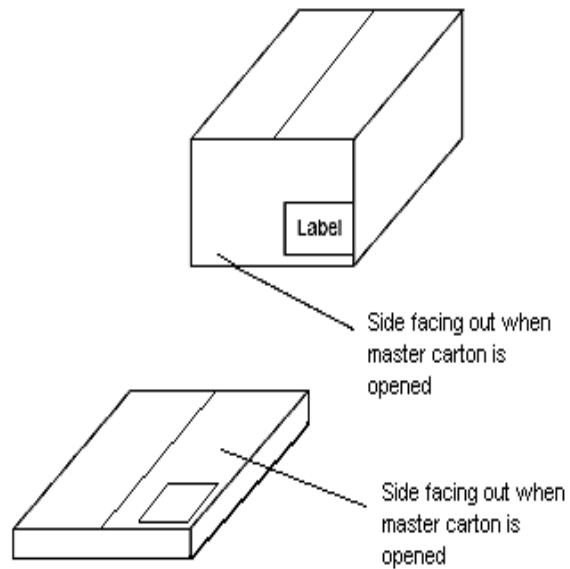

Inner Carton Label Example

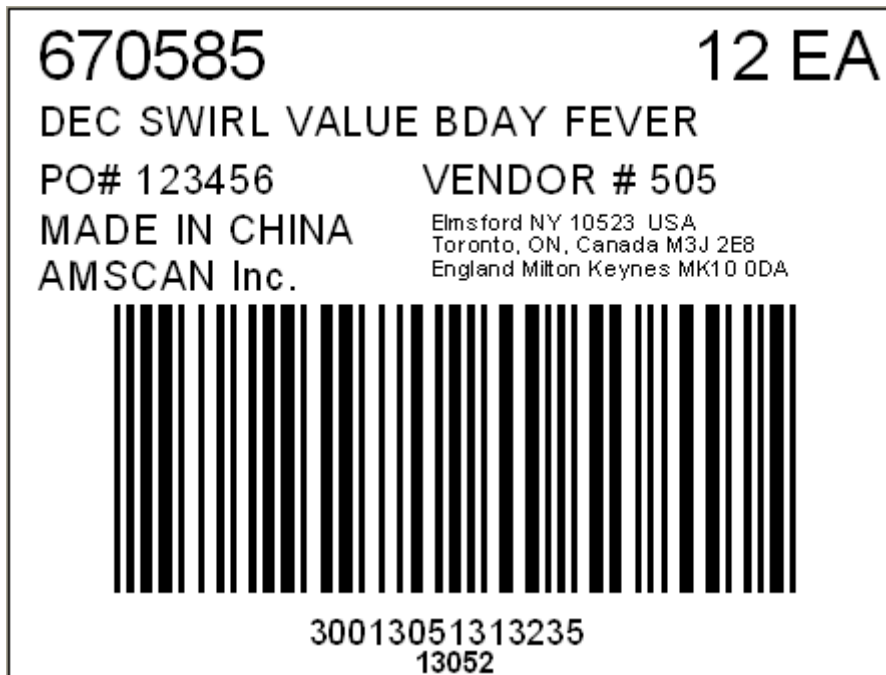

*** 300 – Series bar code denotes this carton is an Inner. Eaches Labels**

The correct printing of clear UPCs is of primary importance due to market sensitivity. If an incorrect UPC is printed, or the UPC is un-scannable, there will be a chargeback without warning due to the ramifications of the error.

All barcodes appearing on the label printed for Amscan’s use shall meet the specifications contained herein.

In most cases, Amscan provides the UPC artwork (included with the each packaging artwork) to our vendors. Whether or not Amscan supplies eaches label artwork, the vendor should pay specific attention to the following guidelines.

Eaches Label Guidelines

- White labels are to be used unless specifically directed otherwise
- Print in black
- All UPC's should be in standard UPC-A format and scan at the grade level of "C" or better
- Barcode must be scannable
- Label size needs to be an appropriate size for the item (no overhang)
- One label is to be used unless the item/each come in a box, container, or display. In this case the box, container, or display AND the piece must each have the label.
- The following information needs to be on the labels
 - Amscan item #
 - Your Amscan Vendor Number
 - Country of origin
 - UPC/barcode
 - Human readable version of the bar field must appear directly below the barcode

Section – 3b (Wholesale)

- Amscan name and locations (if applicable)
- Production code printed below or to the side the Bar Code – (Julian Date Code)
- Example – June 1, 2009 to read as follows 09152.

Eaches Label Examples

EXAMPLE OF AMSCAN ITEM UPC LABEL

Sample UPC has been enlarged for viewing

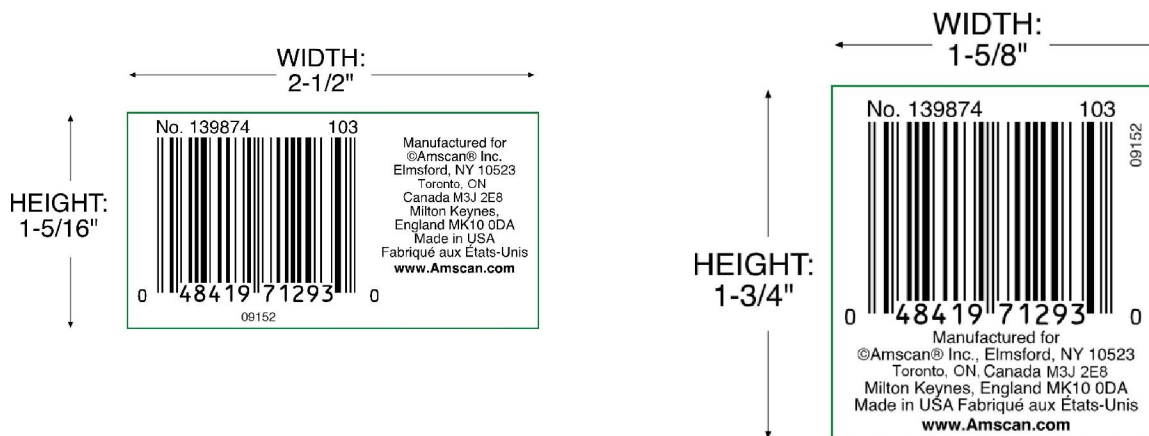

EXAMPLE OF GRASSLANDS ROAD ITEM UPC LABEL

Sample UPC has been enlarged for viewing

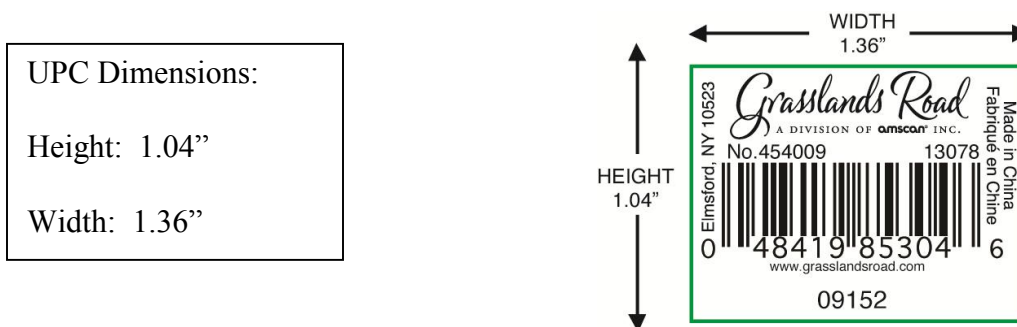

PACKAGING/LABELING FOR CANDY PRODUCTS

DATE CODE REQUIREMENT

For all candy products, we have instituted a specific date code requirement to identify the production date of the candy. This 10 digit identification number is referred to as the Lot Number.

The Lot Number consists of the calendar date of production placed between 2 pairs of numbers as follows:

Position #s start from left to right

- Positions 9 & 10: will list as 99 and will not change
- Positions 7 & 8: represents the month
- Positions 5 & 6: represents the day
- Positions 3 & 4: represents the last 2 days of the year
- Positions 1 & 2: will list as 00 (a constant number for now – however, this could potentially change if needed in the future)

An example of the Lot Number with the calendar date of January 1, 2008 would be listed as:
9901010800

An example of the Lot Number with the calendar date of April 25, 2008 would be listed as:
9904250800

Master Carton Lot Number

The Lot Number must be printed directly onto the Master Carton as large as possible. It must be printed on the top right hand corner on each side of the Master Carton. Please refer to the following example.

i.e. LOT # 9901010800



Section – 3b (Wholesale)

Inner Carton Lot Number

The Lot Number must be printed on the inner carton label as large as possible underneath the inner UPC code. Please refer to the following example.

i.e. LOT # 9901010800



Package Lot Number

The lot Number must be printed directly onto the package at the lower right corner of the package as legible as possible. Please refer to the following example.

i.e. 9912010700

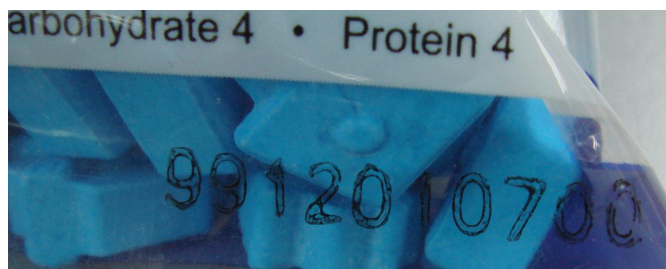



Section – 3b (Wholesale)

Manual calculation of the check digit for Amscan labels

Symbology for Inner and Master Label

Both use the Interleaved 2 of 5 (I 2/5) symbology with 14 digits of numeric data. The data looks like this:

13	12	11	10	9	8	7	6	5	4	3	2	1	CH
----	----	----	----	---	---	---	---	---	---	---	---	---	----

where

digit #	definition
13	for the Inner, it is always a 3; for the Master, it is always a 5
12	always a zero
11 – 1	left most 11 digits from the UPC #
CH	check the digit calculated based on the other 13 digits

Calculation of the check digit:

1. Sum of the digits in the ODD positions and multiply the result by 3
2. Sum the digits in the EVEN positions and add to the above result
3. Find the digit to add to the result of 2. Above so that the new number ends in zero. That digit is the checksum digit.

Example: 43030.01 7" PLSTC PLATE 20 CT-REGL BLUE UPC 012795107581

Inner Box Bar Code

3 0 0 1 2 7 9 5 1 0 7 5 8

1. $3 + 0 + 2 + 9 + 1 + 7 + 8 = 30$

$30 * 3 = 90$

2. $0 + 1 + 7 + 5 + 0 + 5 = 18$

3. $90 + 18 = 108$

$108 + CH = 110$; $CH = 110 - 108 = 2$

Therefore, the Inner Box Bar Code is: 30012795107582

Master Box Bar Code

5 0 0 1 2 7 9 5 1 0 7 5 8

1. $5 + 0 + 2 + 9 + 1 + 7 + 8 = 32$

$32 * 3 = 96$

2. $0 + 1 + 7 + 5 + 0 + 5 = 18$

3. $96 + 18 = 114$

$114 + CH = 120$; $CH = 120 - 114 = 6$

Therefore, the Master Carton Box Bar Code is: 50012795107586



Section - 3d (Retail – Canada Only)

Packaging & Packing Instructions

Overview – Party City Canada (includes Party City in Canada ONLY)

As business partners driving mutually beneficial supply chain efficiencies, this section contains detailed instructions on packaging, carton labeling and marking, and shipment documentation for merchandise shipped to Party City Canada. Party City Canada is committed to working with our vendor partners to improve product packaging/handling and to increase automation efforts.

It is expected all vendors will comply with the requirements set forth in this Vendor Standards Manual. Non-compliance will result in reimbursements to Party City Canada for processing expenses incurred due to non-compliance. Reimbursements are outlined in Reimbursement and Waiver Policy, Section 8.

All labels applied directly to product must include a removable adhesive so product is not damaged. Placement of labels should not block the UPC or otherwise interfere with operating or product care instructions, as well as any other pertinent product information. For more information regarding item packaging, see section 1, *Item UPC Label Guidelines*.

Packaging Instructions for Merchandise

In order to expedite the receiving of cartons and maintain a high level of accuracy in processing, the following guidelines have been established:

- Only one PO per carton is permitted.
- Each selling unit must contain a valid, scannable, Universal Product Code (UPC) clearly visible and affixed.
- Carton weight should not exceed 45 pounds, unless the product itself weighs more than 45 pounds. If so, a sticker indicating the product exceeds 45 pounds must be attached and clearly visible.
- Seal shipping cartons with tape or light adhesive. Do not use staples or bands.
- Package merchandise in new sturdy cartons capable of withstanding normal shipping and handling.
- PO should be shipped utilizing the least number of cartons while maintaining shipping container integrity and not incurring additional freight charges.
- Do not use loose fill in shipments such as foam chips, shredded paper or straw like material without obtaining prior written approval from the Logistics Department. If approval is obtained, clearly identify on the cases with loose fill, in clear writing, that **"loose fill is contained within"**.
- Location address, including store number, and PO number are to be CLEARLY marked on the outside of each carton. A Party City Canada approved UCC 128 label is required for all shipments.
- When multiple carton shipments are made, cartons are to be marked 1 of X, 2 of X, ... X of X.



Section - 3d (Retail – Canada Only)

- Packing slip is to be enclosed in or affixed to the lead or last carton. If it is enclosed within a carton, the carton must be clearly labeled indicating the packing slip is enclosed. Clearly labeled is defined as a label with a minimum size of 2" x 3" and lettering of at least a size 22 font. Multiple PO's shipped on the same day must be packed individually.

Unless granted advance written approval from the Party City Canada Logistics Department, shipments not meeting the minimal requirements may be refused upon delivery and returned to the vendor at the vendor's expense. When shipping small packages consolidate to the largest carton size available to minimize # of cartons shipped. Only master cartons should have the GS1-128 label, containing information for all inner cartons.

CONEG: Packaging Requirement

Manufacturers and suppliers of packaging and packaging components are required by law to furnish a certificate of compliance to customers upon request (refer to the introduction section). This applies only to companies who actually put their products in the package and does not apply to the retailer or the individual consumer. The public and state also have access to these certificates.

Should there be any problems after cartons are received, or there is non-compliance with the above criteria, a redesign will be done to comply. Watch this very carefully so that this process and potential chargebacks can be avoided. Failure to meet the Quality Control guidelines will result in penalties as listed in Section 8 (Reimbursement And Waiver Policy) and Section 9 (Terms and Conditions)

Traceability

Children's products will need permanent distinguishing marks on the product, to the extent practicable, to identify the manufacturer, location, date of production and other necessary information for all goods manufactured on or after 8/14/09.

Marking/Labeling of Cartons

Party City Canada's EDI Team will oversee the approval of the GS1-128 label. Vendors must follow these guidelines for labeling cartons:

Prior to ASN Certification, vendors must include the following on their labels:

- Store Number
- Purchase Order Number
- Store Name and Address
- When multiple carton shipments are made, cartons are to be marked 1 of X, 2 of X, etc...
- All master cartons must be clearly marked with a label no smaller than 2" x 3" and no larger than 3" x 4" containing the department description, such as: Halloween, Valentine's Day, Replenishment, Everyday, etc. For example, Halloween merchandise should read, "HALLOWEEN" on the outside of the carton. The font must be no smaller than 48 point font and must fit on the label used.



Section - 3d (Retail – Canada Only)

Upon ASN Certification, vendors are responsible for the following:

Effective for all shipments on the date of ASN certification, carton labels for all Party City Canada shipments must be a 4" x 6" GS1-128 shipping label. Each vendor is responsible for supplying GS1-128 labels (as outlined later in this section). These labels may be made in-house with bar-code software or vendors may outsource this responsibility. Party City Canada reserves the right to make future label changes should it be deemed necessary.

ASN Certified vendor labels must include the following:

- All Party City Canada Purchase Order (PO) numbers must not be modified and must be human readable.
- All Party City Canada SKUs must be human readable.
- The quantity must always be human readable. The quantity must reflect the number of selling units. For example, if shipping 24 units of an item, the quantity would be 24. No decimals are used.
- The Party City Canada department number must be human readable. The Department No. is provided on all Party City Canada POs. If unclear of the Department No., contact the Party City Canada Merchandise team to identify the Department No.
- GS1-128 labels must be placed on the lower right hand corner of the longest side of the master carton approximately two inches from the carton edges. There should be no labels on the inner cartons. All ASN information for inner cartons should be contained under the label on the master carton.
- Each carton must only have one GS1-128 label
- When multiple carton shipments are made, cartons are to be marked 1 of X, 2 of X, etc...
- All merchandise must be clearly marked with the department description, such as: Halloween, Valentine's Day, Replenishment, Everyday, etc. For example, Halloween merchandise should read, "HALLOWEEN" in box 5 of the UCC 128 label. The font must be no smaller than 48 point font and must fit on the label used. Refer to the label format examples in this section for more information. If unclear of the department, contact the Party City Canada Merchandise team.

The department information is sent on an 850 EDI PO in the PER segment as a Department Code. The descriptions for those Department codes are:



Section - 3d (Retail – Canada Only)

Dept Code	Department code description	Dept Code	Department code description
CSTK	CASE STACK PRESENTATION	30	HANUKKAH
36CH	CHINESE NEW YEAR	44HK	HANUKKAH CANDY
31	CHRISTMAS	WEB	Internet Store
44CH	CHRISTMAS CANDY	56	MARDI GRAS
36CI	CINCO DE MAYO	56BK	Mardi Gras Bulk
22	COMMUNION	NS	NEW STORES
55	COSTUME ACCESSORIES	32	NEW YEARS
55BK	COSTUME ACCESSORIES BULK	36PA	PASSOVER
27	COSTUME SHOP	24	PATRIOTIC
27BK	COSTUME BULK	24BK	PATRIOTIC BULK
21	EASTER	36PU	PURIM
44EA	EASTER CANDY	REPLN	REPLENISH
EVERY	EVERYDAY	7	SPRING
28	FALL	20	ST PATRICK'S DAY
FEDRP	Franchise store initiated ED replenishment orders	25	SUMMER
23	GRADUATION	25BK	SUMMER BULK
23BK	GRADUATION BULK	18	SUPERBOWL
26	HALLOWEEN	29	THANKSGIVING
26BK	HALLOWEEN BULK	44VA	VAL CANDY
44HA	HALLOWEEN CANDY	19	VALENTINES
Special Use Buyer Codes			
FEDAY	Amscan Only- FRANCHISE ED REPL	XBUK	ED BYPASS
FEDSO	Amscan Only- FRANCHISE SOLIDS REPL	GBUK	ED PROMOTIONS

Label Format

Labels must include the following information and must be in the format specified by Party City Canada. Remember to include the field identifier numbers when bar-coding.⁴

BOX 1	FROM	Vendor name and address where the merchandise ships from
BOX 2	TO	Party City Canada, store number, address and postal code that merchandise is being sent to or the destination as specified on the PO.
BOX 3	SHIP TO POST	Ship to postal code must be human readable and bar-coded.
BOX 4	CARRIER INFORMATION	SCAC code and one of the following: Tracking number, PRO number, Bill of Lading (BOL) number.
BOX 5	DENOTE DEPARTMENT DESCRIPTION	The vendor must input the department description. Department Code is obtained from the PO.
BOX 6	DEPARTMENT	Party City Canada department in which the vendor product is categorized. Department information is obtained from PO.
BOX 7	SKU UPC DESCRIPTION OR MIXED	The Party City Canada SKU number must be human readable. Should also contain UPC and the Party City Canada Item description. If more than one SKU per carton, the SKU should read "MIXED", UPC should be blank, and the Description should be blank.





Section - 3d (Retail – Canada Only)

BOX 8	PO NUMBER PARTY CITY CANADA VENDOR NUMBER	The PO# appearing on the Party City Canada PO. PO# must be human readable. The vendor number is the Party City Canada assigned vendor number appearing on the PO.
BOX 9	QUANTITY	The quantity must be human readable. The quantity is the total number of selling units in a carton. Field must be blank if more than one SKU in carton.
BOX 10	MARKED FOR	Final destination of the merchandise. The store number is two or three digits in length, must be human readable. Must use the full address of the final destination. Please use larger font for store no. (font size 48).
BOX 11	SSCC-18 STANDARD GS1-128 BAR CODE	Carton serial number, which must be unique and never repeated on any cartons or shipments. This must be human readable and bar-coded for a total of 20 digits. "00" is the application identifier. Position 18- must use "0" to indicate the shipping container is a case or carton. Position 17 – "0" indicates your company has a unique number assigned by the UCC. Positions 11 through 16 - indicate the unique number assigned to your company by the UCC. Positions 2 through 10 – indicate the sequential numbering of cartons, unique for each carton and not repeated for 2 years. Position 1 – Modulo 10 check digit.



Section - 3d (Retail – Canada Only)



Party City Canada GS1-128 Label Format
Carton Label Requirements
Single SKU Label Format
For Direct to Store Shipments

Box 1	From: XYZ Party Supply 123 Party Place Anytown, NJ 07866	To: Party City Canada Store #01 1225 Finch Ave. Toronto, ON, M3J 3B5	Box 2
Box 3	M3J 3B5 	Carrier Information	Box 4
Box 5	<h1>Halloween</h1>		
Box 6	Dept. 26	SKU: 12345	Box 7
Box 8	PO #: 123456789	UPC: 021300147097	
	Vendor #: 111	Description: Party City Canada Item	
Box 9	Quantity 0024	#01 1225 Finch Ave. Toronto, ON, M3J 3B5	Box 10
	 (00) 0 06 14141 123456789 0		Box 11



Section - 3d (Retail – Canada Only)



Party City Canada GS1-128 Label Format
Carton Label Requirements
 Multi - SKU Label Format
 For Direct to Store Shipments

Box 1	From: XYZ Party Supply 123 Party Place Anytown, NJ 07866	To: Party City Canada #01 1225 Finch Ave Toronto, ON, M3J 3B5	Box 2
Box 3	M3J 3B5 	Carrier Information	Box 4
Box 5	<h1>Halloween</h1>		
Box 6	Dept. 26	SKU: MIXED	Box 7
Box 8	PO #: 123456789	UPC:	
	Vendor #: 111	Description:	
Box 9	Quantity	#01 1225 Finch Ave. Toronto, ON, M3J 3B5	Box 10
	 (00) 0 06 14141 123456789 0		Box 11



Section - 3d (Retail – Canada Only)



Party City Canada GS1-128 Label Format
Carton Label Requirements
Single SKU Label Format
For 3PL Warehouse Shipments

Box 1	From: XYZ Party Supply 123 Party Place Anytown, NJ 07866	To: Party City Canada DC 2775 Broadway Buffalo, NY 14227	Box 2
Box 3	14210 	Carrier Information	Box 4
Box 5	<h1>Halloween</h1>		
Box 6	Dept. 26	SKU: 12345	Box 7
Box 8	PO #: 123456789	UPC: 021300147097	
	Vendor #: 111	Description: Party City Canada Item	
Box 9	Quantity 0024	#01 1225 Finch Ave. Toronto, ON, M3J 3B5	Box 10
	 (00) 0 06 14141 123456789 0		Box 11



Section - 3d (Retail – Canada Only)

Party City Canada GS1-128 Label Format
Carton Label Requirements
Multi - SKU Label Format
For 3PL Warehouse Shipments

Box 1	From: XYZ Party Supply 123 Party Place Anytown, NJ 07866	To: Party City Canada DC 2775 Broadway Buffalo, NY 14227	Box 2
Box 3	14210 	Carrier Information	Box 4
Box 5	<h1>Halloween</h1>		
Box 6	Dept. 26	SKU: MIXED	Box 7
Box 8	PO #: 123456789	UPC:	
	Vendor #: 111	Description:	
Box 9	Quantity	#01 1225 Finch Ave. Toronto, ON, M3J 3B5	Box 10
	 (00) 0 06 14141 123456789 0		Box 11



Section - 3d (Retail – Canada Only)

Packing Slips

Party City Canada requires a packing slip for all shipments. Only 1 packing slip per PO # shipped. The packing slip must contain the following information:

- Party City Canada PO number
- Party City Canada Store Number
- Number of cartons
- Item descriptions, SKU # (only if EDI certified)
- Item quantities
- Grand total units

For common carrier shipments, insert packing slips into a removable pouch and place on the outside of a "Lead Carton" (1 of X) or "Last Carton" (X of X) for each shipment. Indicate "Lead Carton" on carton or place in a "Packing Slip Enclosed" preprinted pouch. In addition, the packing slip can be placed inside a "Lead Carton" or "Last Carton" where the carton is clearly labeled "Packing Slip Enclosed" on the outside of the carton. The carton containing the packing slip must be placed on the top layer of the pallet with the clearly marked "Packing Slip Enclosed" area facing out. Each Bill of Lading must be marked with the actual carton count.

For parcel shipments, the carton labeled 1 of X is the "Lead Carton," and the carton labeled X of X is the "Last Carton." Follow the instructions described above for packing slip placement.

Section – 4a,c,d (Retail)

Product Safety and Quality Assurance

Overview – Party City (includes Party City, Party America, Party City Canada and Halloween City)

Vendors shipping product directly to any retail entity of PCHI (The Company), including Party City, Party America, and Halloween City locations, shall be required to have previously tested their products to meet all applicable local, state and federal regulations at the time of sale. All test results shall be made available upon request and sent to sp.retailtestreports@amscan.com and copied to Hsin Chen at hchen@amscan.com, Jamie Yang at jyang@partycity.com and Jared Briden at jbriden@partycity.com before shipment. It is expected that all vendors will have testing information within the past calendar year or season, as applicable, on file for their product and be compliant with respect to the terms and conditions outlined in the Vendor Standards Manual (Section 9). In the event testing results are not available, the retail entity will require that your product be sent to a third party, independent testing laboratory which is approved by the Consumer Product Safety Commission to test products in accordance with the Consumer Product Safety Improvement Act of 2008 (CPSIA), for testing at your expense. This applies to all items that are shipped to US stores and that do not bear the Amscan brand and/or Amscan USA address, regardless of whether or not the item is shipped directly to PCHI retail stores by the vendor or is distributed by Amscan.

The Consumer Product Safety Improvement Act of 2008 and the Consumer Product Safety Acknowledgement is also on the Party City Vendor Website and needs to be signed and returned.

Certification and Testing Documentation

Vendors must certify based on a test of each product they supply The Company's retail outlets or upon a reasonable testing program that all product The Company's retail outlets purchases complies with all rules, bans, standards, or regulations applicable to that product under the Consumer Product Safety Act of 2008, any other Act enforced by the Consumer Product Safety Commission (CPSC), and all U.S. FDA Codes of Federal Regulations (CFR). Upon request by The Company's retail outlets, vendors must supply to The Company's retail outlets via email at pcps.testreports@amscan.com all certification and testing documentation for any products they supply The Company's retail outlets within two business days. GCC's and CPC's may be emailed to pcps.gcc@amscan.com.

In accordance with the new laws put forth by the Consumer Product Safety Improvement act of 2008 (CPSIA) a General Certificate of Compliance (GCC) will need to be provided with shipments of toys and children's items, and some other applicable products such as general purpose lighters, wearing apparel, and art materials. You need to submit the GCC with the shipping documents for items imported into the country and also send via email a copy (for all applicable items) to the Amscan database at the email addresses listed at the bottom of the GCC document enclosed at the end of this Section 4a,c.

The GCC needs to be included with every shipment into the United States and every applicable item needs to have at least one GCC on file.

Section – 4a,c,d (Retail)

Product Safety and Quality Assurance

CPSIA and Safety Requirement Guidelines

The Consumer Product Safety Improvement Act of 2008 (CPSIA) changed the safety requirements of many items sold by The Company's retail outlets. As part of The Company's commitment to fully comply with CPSIA, it is mandatory that products supplied to The Company's retail entities by its vendors covered under the Consumer Product Safety Improvement Act of 2008 (the Act) be in compliance with all requirements of this legislation. This includes, but is not limited to, the following areas of the Act:

- Children's products containing lead and the lead paint rule. (Title I – Section 101 of the Act)
- Mandatory third party testing for certain children's products and certification requirements. (Title I – Section 102 of the Act)
- Tracking labels for children's products. (Title I – Section 103 of the Act). A children's product must contain a permanent, distinguishing mark on the product and its packaging, to the extent practical, that will enable the manufacturer and ultimate purchaser to ascertain the manufacturer, location and date of production of the product, and cohort information including: Item# - Vendor# - Year Made – Country of Origin. This information shall be included on each individual children's product manufactured on or after August 14, 2009, as practicable, Traceability information shall use a minimum font size of 1/32 inches based on lower case "h" as a guide to help determine if applying traceability information in accordance with Title I – Section 103 of the Act is practicable.
- Labeling requirements for children's toys and games, and the vendors obligation to provide the necessary cautionary statement information required by the Act. (Title I – Section 105 of the Act)
- Mandatory toy safety standards. (Title I – Section 106 of the Act)
- Prohibition on sale of certain products containing specified phthalates. (Title I – Section 108 of the Act)

Food and Products that come into contact with Food

Vendors that supply PCHI with food and products that come into contact with food are required to comply will all U.S. FDA (Food and Drug Administration) regulations, including **the Food Safety Modernization Act (FSMA)**, U.S. FDA CFR Title 21, **including but not limited to Part 117**, and Proposition 65 regulations. For those facilities that produce food, the following documentation, with satisfactory result(s) is required, but not limited to: i) factory contact & address, ii) GMP food facility certification audit, or equivalent, iii) product test report(s) in accordance applicable test protocols, iv) packaging claims and independent, third party substantiation, v) certificate(s) of insurance, vi) product and process inspection plan in accordance with FDA or equivalent methodology, vii) current social compliance audit per PCHI Code of Conduct requirements, viii) current FDA bioterrorism registration certificate, and ix) applicable country certification(s) required by local or national law.

Glassware

Vendors that supply The Company's retail outlets with printed or painted glassware products are required to comply with all U.S. FDA regulations, including U.S. FDA CFR Title 21, and Proposition 65 regulations.

Certification and Testing Documentation

Vendors must certify based on a test of each product they supply The Company's retail outlets or upon a reasonable testing program that all product The Company's retail outlets purchases complies with all rules, bans, standards, or regulations applicable to that product under the Consumer Product Safety Act of 2008, any other Act enforced by the Consumer Product Safety Commission (CPSC), and all U.S. FDA Codes of Federal Regulations (CFR). Upon request by The Company's retail outlets, vendors must supply to The Company's retail outlets via fax at 973-983-4736 all certification and testing documentation for any products they supply The Company's retail outlets within two business days.

Cautionary Statements

As detailed in Section 105 of the Act, vendors are required to inform The Company's retail outlets of all internet and printed material advertisement cautionary statement requirements for product they supply The Company's retail outlets. Under the Act, vendors not only are required to inform The Company's retail outlets of the any product requiring a cautionary statement, vendors must also inform The Company's retail outlets of the cautionary statement details necessary to be in compliance with the Act.

If revisions to this Act, other CPSC Acts, U.S. FDA CFR's, or future consumer safety legislation or regulation results in additional or alternate safety requirements, our vendors are required to meet those standards. This includes, but is not limited to, requirements specified in our Vendor Standards Manual and state regulations of Proposition 65, CONEG Toxics in Packaging regulations, Washington State Chemicals of High Concern to Children (CHCC), Maine Toxic Chemicals in Children's Products, Oregon's High Priority Chemicals of Concern for Children's Health, or any other applicable laws.

State Chemicals in Children's Products

There are certain chemicals which have notification and/or regulatory requirements for the states of Maine, Oregon, Vermont, New York and/or Washington in the United States. If your product(s) contain chemicals from the PCHI Chemical List (last updated on 2/1/2016, made available on Party City's Vendor Portal, and updated from time to time) that are **unintentionally** added to children's products above the Practical Quantitation Limit (PQL), which, for practicable purposes, is 100 ppm (0.01%), please inform PCHI of the chemical name and amount by weight of the chemical in the product. [Please note that the PQL is based on the test methodology used for chemical detection]. If you have testing done to levels below 100 ppm for any chemicals on the PCHI Chemical List that are **intentionally** added, then please inform us of the level to which the chemicals are being measured and the level of the chemical.

Some chemicals with a check mark on the PCHI Chemical list for SVHC also have a check mark for Maine, Oregon, Vermont, New York and/or Washington State. These chemicals, if present, need a corrective plan to find a suitable replacement. Note that Lead (Pb), Cadmium (Cd), Arsenic (As), Antimony (Sb), Mercury (Hg), Bisphenol A (BPA), Formaldehyde, and Phthalates DBP, DEHP(DOP), BBP, DINP, DNOP, DIDP, DIOP, DIBP, DPP(DPENP), DNHP(DHEXP), DCHP, DEP, and MBP (CAS#131-70-4) do not require notification since a control program as stated in this Vendor Standards Manual ("VSM") and PCHI's Guidelines for Children's and Other Products is in place to ensure that the products you supply to PCHI and its affiliated companies comply with applicable local, state, and federal regulations for these chemicals. For example, Lead in surface coating and substrate needs to be under 40 or 90 ppm, depending upon product category, and under 1 microgram using the NIOSH 9100 test according to California Proposition 65 regulations, Phthalates need to be under 1000 ppm (0.1%), and total Cadmium needs to be under 75 ppm.

CFR 1107

As part of US federal regulation 16 CFR 1107 requirements effective February 8, 2013 for children's items, PCHI needs to ensure that all items comply with applicable regulations.

In addition to the current periodic production testing, GCC or CPC, and random sampling that PCHI is already doing with your cooperation, please ensure the following:

1. You inform PCHI of any significant changes in materials, factories, processes, designs, or construction for children's items that you manufacture for PCHI. A sample Product Change Notice (PCN) form is enclosed in 4(b) section for your use or reference.
2. Your company has on file, and viewed by all, a written policy statement from a company officer stating that the exercise of undue influence on third party conformity assessment bodies is not acceptable, a letter to all appropriate staff members to receive training on this policy, and a signed statement attesting to their participation in such training.

If there are any reports of alleged undue influence, please investigate immediately and inform PCHI as soon as possible. If you have any questions on the requirements of 16 CFR 1107 or your obligations to PCHI, please contact us immediately.

CPSIA and Safety Requirement Guidelines Acknowledgement

To acknowledge your receipt of this VSM's Product Safety and Quality Assurance requirements, please indicate which PCHI retail entity you are supplying, sign and date this document to certify that all products you supply to PCHI's retail entity are in compliance, and will continue to be in compliance in the future, with the Consumer Product Safety Improvement Act of 2008, other Consumer Product Safety Commission Acts, and all applicable U.S. FDA or state regulations. Please return a copy of the signed and dated document to the fax number of the Product Safety retail entity representative. (All retail entity contacts are listed in Section 11 of this Vendor Standards Manual).

If you have any questions, please contact the respective representative of The Company's retail entity anytime.

PCHI Retail Entity _____

Vendor Signature _____

Printed Name _____

Title _____

Company Name _____

Date of Signature _____

Please refer to *Party City, Party America, and Halloween City Guidelines for Children's and Other Products* on the vendor website, www.partycityvendors.com for a summary of specific product safety requirements (Vendor Compliance Guidelines - Retail PDF). A copy of this is in the Appendix.

All vendors that ship direct to PCHI retail locations must complete and email or fax this acknowledgement form to vendorrelations@partycity.com or fax to 973-983-4915.

GENERAL CERTIFICATE OF CONFORMITY FOR CONSUMER PRODUCTS

CERTIFICATE DATE:

CERTIFIED BY:

MANUFACTURER NAME:

ADDRESS:

CITY:

STATE/PROVINCE:

COUNTRY:

PHONE#:

Importer: (Name, Address & Phone #)

Importer: (Record Keeping Contact)

Item Number	Item Description	Vendor Number	Purchase Order #	Date of Manufacture (Month/Year)	Place of Manufacture (Factory Name, Address & Phone #)	Testing Date (Month /Year)	Place of Testing/ Third Party Testing Lab (Name, Address & Phone #)

In accordance with Section 14 of the Consumer Product Safety Act, 15 U.S.C. 2063(a), the manufacturer certifies that based upon a test or a reasonable test program, the product listed above complies with all applicable consumer product safety rules, bans, regulations or standards under the Consumer Product Safety Improvement Act (CPSIA) of 2008 or any other Act enforceable by the United States Consumer Product Safety Commission, as indicated in Table 1 below (check all that apply):

Check All
That Apply

Table 1: Consumer Product Safety Rules (Children's & Other Applicable Products)

<input type="checkbox"/>	Lead in Surface Coating (Children's Product)	16 CFR 1303
<input type="checkbox"/>	Lead in Substrate (Children's Product)	CPSIA 101
<input type="checkbox"/>	Lead in Children's Metal Jewelry	CPSIA 101(a)(2)
<input type="checkbox"/>	Choking Hazard Labeling (Children's Product)	16 CFR 1500.19
<input type="checkbox"/>	Pacifiers (Children's Product)	16 CFR 1511
<input type="checkbox"/>	Rattles (Children's Product)	16 CFR 1510
<input type="checkbox"/>	Children's Products with Liquids	16 CFR 1500.14
<input type="checkbox"/>	Toys (ASTM F963)	CPSIA 106
<input type="checkbox"/>	Flammability of Solids (Children's Product)	16 CFR 1500.44
<input type="checkbox"/>	Flammability of Textiles (Adult & Child)	16 CFR 1610
<input type="checkbox"/>	Flammability of Plastic Film (Adult & Child)	16 CFR 1611
<input type="checkbox"/>	Phthalates in Toy & Childcare Items	CPSIA 108
<input type="checkbox"/>	Art Materials (LHAMA)	16 CFR 1500.14(b) (8)
<input type="checkbox"/>	Other (please specify)	<input type="text"/>
<input type="checkbox"/>	Other (please specify)	<input type="text"/>

*NOTE: Manufacturer shall email this WORD document using the naming format: **SKU#_Vendor#_Certificate Date with MMDDYYYY (For example, SKU 123456 from vendor number 999 made on November 12, 2008 would be 123456_999_11122008.doc)** to the following distribution: pcps.gcc@amscan.com



Section - 4b (Wholesale)

Product Safety and Quality Assurance

A. INTRODUCTION & OVERVIEW

The global marketplace is demanding and the regulatory environment for consumer product safety is ever changing. PCHI is committed to taking a leadership position in providing innovative, fun and safe products to consumers all over the world and we expect that our suppliers share that commitment.

PCHI (Party City Holdings Inc), and affiliated companies, including, but not limited to Amscan, and Anagram International, is dedicated to ensuring that all of its products meet or exceed federal, state and municipal requirements. To this end, PCHI conducts rigorous testing of its products both internally and with government-approved testing organizations. Any product that fails to meet governmental or PCHI's standards will not be distributed.

As part of PCHI's continuous efforts to ensure the safety, quality and integrity of our products from production and shipment through retail sale and consumer use, PCHI wants to emphasize that we treasure all our vendors and suppliers whom we trust to manufacture and ship our products. PCHI relies upon our suppliers to support PCHI policies and needs your support and full cooperation on the following:

Raw Material Testing

It is difficult to overstate the importance of using safe and good quality materials in all the products, designs and components made for PCHI. If products start with safe and good quality materials, we can be assured that the finished products will be in compliance with regulations set forth for heavy metals and other chemicals such as phthalates, lead, cadmium, mercury, antimony, arsenic, barium, cadmium, chromium, and selenium. Accordingly, it is recommended that all vendors have testing results and certificates from all their suppliers showing that the raw materials used for PCHI products are safe and compliant for all of the markets where PCHI's products are sold. This should include, but not be limited to, lead and heavy metals in the inks, plastic resins, coatings and paper stock.

Prototype Testing and Internal Design Evaluation

Some product categories are quite complicated and it is prudent to evaluate certain products and resolve safety or quality issues before starting mass production. For example, children's items, jewelry, food contact products, apparel, cosmetics, candles, art materials, scene setters, and liquid containing items typically require unique and extensive evaluation. PCHI is aware that this may impact the production start and be an additional cost for vendors. As a result, we urge vendors to send prototype samples for testing as soon as they have been finalized and have the samples tested to protocols that PCHI specifies. To have as accurate a prototype as possible, PCHI highly recommends using materials that have been tested to be in compliance with applicable standards and PCHI is readily available to help its vendors in selecting the appropriate testing protocols for all products. PCHI also encourages vendors to cooperate early in the development cycle for packaging and labeling evaluation. The earlier vendors submit the sample(s) for evaluation, the earlier they will get useful information and keep production schedules. For certain products as those categories mentioned above, PCHI does not recommend starting mass production prior to prototype samples receiving a passing grade from a CPSC-approved, independent, third party testing laboratory. From time to time, PCHI will specify that prototype testing be done for a specific item. In those cases where prototype tests are initiated by PCHI, PCHI will pay for the reasonable testing fees unless otherwise indicated.



Section - 4b (Wholesale)

Production Sample Testing

Production sample testing is a true indicator of a finished product's safety or quality level. On specific products, shipments or receipts will not be authorized prior to production sample(s) receiving a passing grade by PCHI's designated third party testing laboratory. PCHI's purchase orders, and/or an email from the local PCHI office, will indicate which items need to be tested prior to shipment. It is critical that shipment of the specified products not occur without PCHI's confirmation to you of a pass testing result on the production samples or PCHI's agreement that the product can ship without a testing report. If shipment occurs without a passing test report or PCHI approval, vendors will have full responsibility for all liabilities incurred by PCHI as noted in the purchase order. In addition, once an item passes testing, no changes can be made to that product without PCHI approval and, in certain cases, another test. Changes include, but are not limited to, change of ink or paint, change of raw material, reduction of weight, new mold design, new subcontractor used or any other significant change in the product's design, construction, appearance or materials. Depending upon factory location and other risk assessment factors, PCHI will either pick up the production sample(s), request vendors to deliver finished production sample(s) to the local PCHI office, or arrange for sample delivery based on a mutually agreed process. However, if the product fails testing and the test is proven to be valid, vendors will need to pay for each subsequent test on that item until it receives a passing result.

Environmental Packaging Regulations

In accordance with environmental regulations for 19 states in the USA, the packaging provided with PCHI products cannot contain an aggregate total of lead, cadmium, mercury and hexavalent chromium in excess of 100 ppm. This is known as the CONEG requirement (Coalition of Northeastern Governors). PCHI expects that all vendors are holding their suppliers to this requirement and PCHI will randomly test for compliance. If it is found that packaging (which includes the disposable parts of the master and inner) used for PCHI products is not in compliance, vendors will be responsible for providing complete remedy. PCHI recommends that vendors have test reports or certificates for all of the finished packaging materials which are used in PCHI products.

Lead and Heavy Metal Testing Resource

PCHI has purchased x-ray devices which can detect lead and other heavy metals in certain products or raw materials. The x-ray devices in Hong Kong, China, and Vietnam are resources available to international vendors for evaluating prototype samples, raw materials or random production samples. X-ray devices located in New York are available to domestic vendors for evaluating pre-shipment samples. If vendors decide to purchase an x-ray device, PCHI is readily available to help them with proper use for PCHI products. Please note that the x-ray device is not a substitute for third party testing, where required.

Occasionally we will need to send suspect items out for laboratory testing. Please be advised that if the laboratory testing results indicate non-compliance with applicable federal or state standards, your company will be charged by PCHI for the cost of the testing. You could also be charged for inventory handling, disposal, lost sales, legal settlement fees, and other associated expenses as indicated in our purchase orders and Section 9 of this VSM.

Phthalate Testing Resource

PCHI has purchased test equipment which can detect the presence of phthalates and other chemicals in certain products and product components. The devices are located in New York, Hong Kong, China, and Vietnam are available as a resource to vendors for evaluating prototype samples, raw materials, random production samples or other pre-commerce materials.



Section - 4b (Wholesale)

We are using the devices to randomly sample incoming, pre-commerce inventory for phthalates and other chemicals. Occasionally we will need to send suspect items out for laboratory testing. Please be advised that if the laboratory testing results indicate non-compliance with applicable federal or state standards, your company will be charged by PCHI for the cost of the testing. You could also be charged for inventory handling, disposal, lost sales, legal settlement fees, and other associated expenses as indicated in our purchase orders and Section 9 of this VSM.

Traceability with Production Date Code

PCHI has added the need for production date code information for all merchandise shipments effective January 1, 2008. By now, vendors should have cleared their on hand materials and have started using date coding which is currently in the format of "Month-day-year". Going forward, PCHI will be implementing Julian calendar date coding and will phase this in to enable a smooth transition at the factory.

For example, the Julian date code for June 1, 2010 would be 10152, where the first two digits are the year and the next three digits are the day of the year. Please refer to the enclosed Julian calendar for future date coding.

The date code should be printed underneath the UPC bar code.

The date code needs to be visible on the product "each", inner and master carton labels.

There are additional traceability requirements for Children's Products as part of the Consumer Product Safety Improvement Act of 2008 (CPSIA) that are effective for applicable products manufactured after August 14, 2009. **Wherever practicable, children's items and other applicable product categories shall contain traceability information that allows the consumer to identify or readily obtain information as to where, when, and by whom the item was manufactured.** Please refer to www.CPSC.gov, the enclosed PCHI Regulatory Guidelines, and supplemental instructions as available for the requirements.

General Certificate of Compliance (GCC)

In accordance with the new laws put forth by the Consumer Product Safety Improvement act of 2008 (CPSIA) a General Certificate of Compliance (GCC) or Children's Product Certificate (CPC) will need to be provided with shipments of toys and children's items, and some other applicable products, that are manufactured after November 11, 2008.

For PCHI, the certificate applies mostly to children's products that are primarily intended for use by children 14 years of age and under, but there are some other product categories that fall under the jurisdiction of the Consumer Product Safety Commission, such as wearing apparel and art materials. PCHI will indicate on its purchase orders which specific items need the GCC/CPC. Please refer to the GCC/CPC template at the end of this section and if you are making a product for PCHI that is included in Table 1, then a GCC/CPC is needed.

The GCC/CPC is verification that an item has passed the required tests for the US market, which are currently done when you send production samples to PCHI's Hong Kong or USA office for test submission. On the applicable items, a PASS test report will need to have been received or verified, and the GCC/CPC completed, before shipping the item. You need to submit the GCC/CPC with the shipping documents and also send via email a copy to the PCHI database at the email addresses listed at the bottom of the GCC/CPC document enclosed.



Section - 4b (Wholesale)

You can send the email certificate as soon as a "Pass" test report is either received or confirmed by the local PCHI office. It is important to have the certificate and pass test report confirmation before shipment since PCHI's brokers will not accept the booking without the proper GCC/CPC. PCHI can accept prior test reports as evidence of compliance as long as:

- 1) The materials, design, processes and factory are the same for the items sent to PCHI as the production sample(s) that were submitted for testing within the past year, and
- 2) The test report(s) contain all applicable tests. For example, toys were tested to the PCHI standards for phthalates, the most recent version of ASTM F 963, flammability, and lead in surface & substrate.

Random Testing and Inspection

Periodically PCHI, or a third party representative, will visit vendor factories to pull samples randomly from production lines and send samples for testing or conduct visual inspection to ensure the quality, compliance and safety levels during production. PCHI also is randomly testing and inspecting finished goods in our US distribution center. In accordance with our purchase order terms and conditions and stated in section 9 of this Vendor Standards Manual, vendors could be held liable for both wholesale and retail economic losses incurred by PCHI arising from vendors' products' non-compliance with applicable standards and PCHI policies, which includes all incurred expenses and costs for failed inspections and conducting re-inspection for corrected merchandise. Inspection standard shall be ANSI/ASQC Z1.4, or equivalent, typically with General Inspection Level II and 2.5% AQL, or as specified by customer requirements. Testing will be conducted on all applicable items from each purchase order received at our warehouse. Should an item be found to have lead, phthalate, and/or heavy metal levels above the acceptable limit, the entire quantity of the specified product from that purchase order will be destroyed or returned to the vendor for correction if possible. The vendor will be charged back the cost of the product, all costs associated with the shipment and delivery of the product to our warehouse, and the cost to safely destroy the product. The vendor will be required to send PCHI replacement product that meets all acceptable levels of lead and/or heavy metals. If the product is needed immediately and cannot be shipped via water, the vendor will be responsible for the air freight expense to expedite the delivery of the product. Please refer to our purchase order notes and Section 9 of this VSM for further clarification.

Note: PCHI reserves the right to require re-testing and/or product inspections when deemed necessary due to among other things, product non-conformities found during the quality assurance process, or during distribution or sale of the merchandise. All costs associated with re-testing will be the responsibility of the vendor.

PCHI expects that vendors will have questions or require further information. PCHI personnel are readily available to help vendors be in compliance with PCHI policies and the applicable market regulations.

B. PRODUCTION SAMPLE TESTING PROCESS

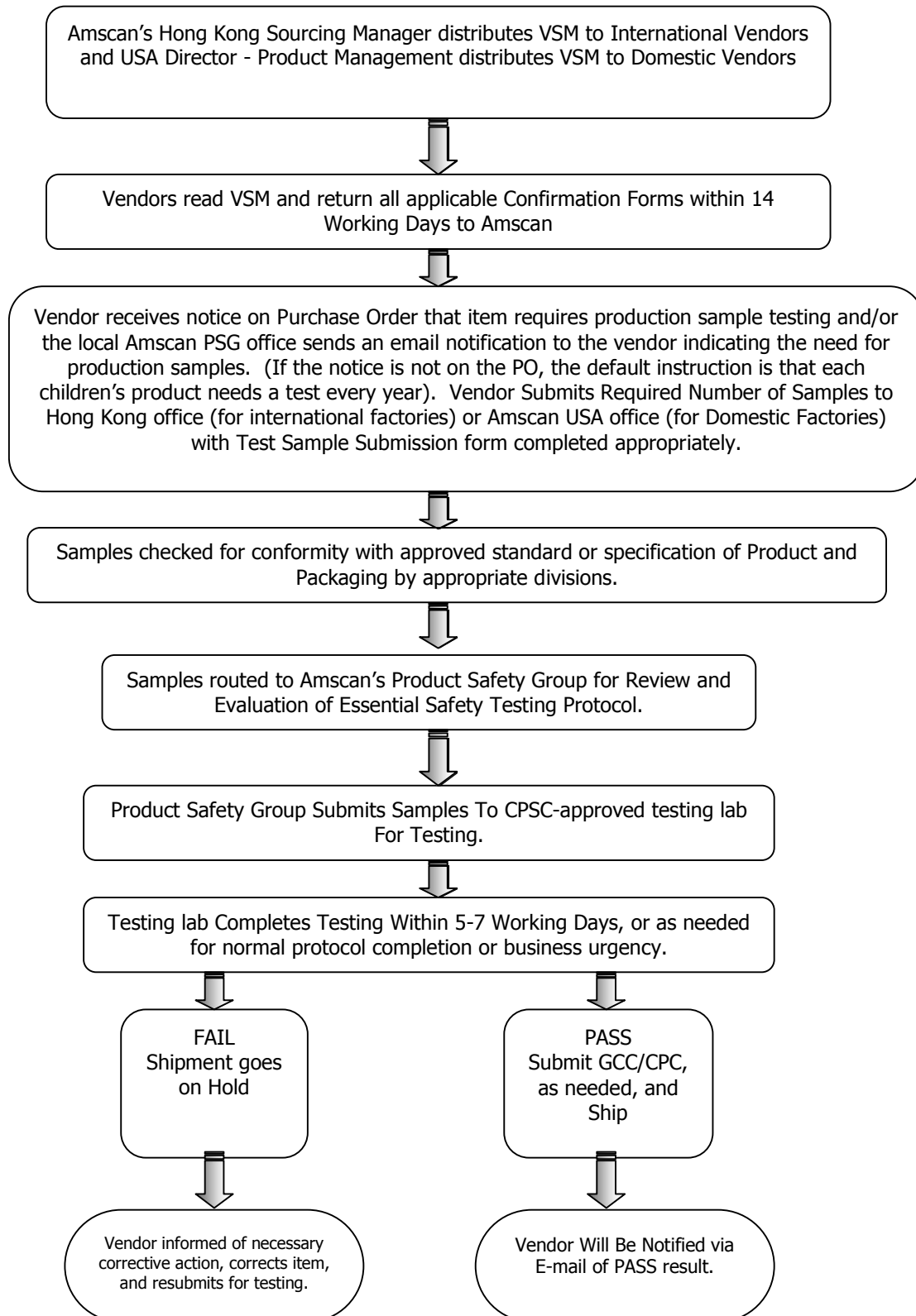



Section - 4b (Wholesale)

C. RESPONSIBILITIES

PCHI's Responsibilities

- Update suppliers/vendors on test procedures and protocols, sample submission requirements and performance standards as changes are made.
- Instruct a vendor when testing is required. The purchase order will indicate which items need to have production samples sent for testing and/or the local PCHI PSG office will send an email notification to the vendor indicating the need for production samples. For items manufactured in Asia or other countries, correspondence will be from PCHI's Hong Kong Product Safety Group. For items manufactured in the Americas, correspondence will be from PCHI's New York Product Safety Group.
- The local PCHI Product Safety and Compliance office will be responsible for subsequent review and determination of essential safety test before submission to a CPSC-approved independent, third party testing lab. Local PCHI office will submit samples. For first time testing, vendors are not required to pay testing charges for the submitted samples.
- Testing results and subsequent test reports shall be distributed to vendors through emails by PCHI's local office.
- When PCHI receives a test report from an approved testing lab where the submission has been rated FAIL, PCHI's Product Safety Group will include a recommended corrective action to accompany the FAIL test report. Shipment cannot occur until the vendor takes corrective action and receives a passing test report, or equivalent approval from PCHI. Vendors are fully responsible to pay for any fail testing fees and re-test charges should the first test fail due to proven vendors' mistakes including but not limited to the sample's inaccuracy, product non-conformity or defectiveness.

Vendor Responsibilities

Sample Submission Procedure

- All PCHI vendors (including domestic USA and international vendors) are obliged to follow PCHI testing procedures to submit production samples for testing and where applicable, relevant ingredient, component list, or MSDS (Material Safety Data Sheet) as required for conductance of the appropriate testing protocol (Please see Section 9, for when an MSDS is required). Accordingly, it is the vendor's responsibility to provide products which are compliant with all applicable voluntary and mandatory standards.
- All samples must either be sent to the appropriate PCHI local office for the purpose of centralized handling or directly to the approved testing lab. They will be checked, examined and logged upon arrival.
- If Vendors decide to send samples directly to the lab, they must use a CPSC-approved testing lab facility and confirm the applicable test protocols with the local PCHI office prior to sample submission and test request. To find out the closest testing facility to your production facility, visit the CPSC website, www.cpsc.gov.



Section - 4b (Wholesale)

- All production testing samples should be sent to the attention of appropriate PCHI local office as follows:

For Overseas (Asia) Manufacturing
Amscan Asia International Ltd
ATTN: Product Safety Group
35/F Saxon Tower
7 Cheung Shun Street
Lai Chi Kok, Kowloon
Hong Kong

For Domestic (North/South America) Manufacturing
Amscan Inc
ATTN: Product Safety Group
80 Grasslands Road
Elmsford, NY 10523

For all other contact information, please refer to Section 11.

Sample Submission Form

Vendors are required to attach a submission form during submission of testing samples to the local PCHI office. The form shall indicate the PCHI item number, Purchase Order (PO) number, item name and description, date manufactured, date sample was sent to PCHI, vendor name, factory address, and vendor contact information. If a vendor is submitting the sample(s) directly to the testing laboratory, the test request form needs to be approved by PCHI's local office.

Quality Assurance Policy

Should vendors have protocols and or their own quality assurance manual in place, vendor shall provide to PCHI, upon request, the manual applicable for all products provided to PCHI. The manual shall include, but not be limited to the following: inspection protocols, quality assurance procedures and policies, and applicable certifications.

Sample Accuracy

- Quantity - Vendors are required to submit production samples at the specific quantity pertaining to the relevant testing protocol. Insufficient samples for testing will result in delay or rejection of submission.
- Approved product specification - Vendors are obliged to submit samples in compliance with PCHI approved product specification. Any deviations to the approved standard will be rejected by the divisions and new production samples to meet approved standard will be demanded for re-submission.
- Approved retail packaging - Vendors must submit complete retail p approved by the relevant PCHI division. Retail packaging includes, but is not limited to, header card, poly-bag, blister clamshell, backer-card, gift box, window box, and instructions for use, as applicable.

Sample Integrity

Samples with retail package should be well protected to ensure the conditions of sample arrival during transit from vendors to PCHI's local office. Samples found to be damaged or broken will not be accepted for testing and new submission will be immediately required.

Sample Labeling Arrangement

Since the PCHI local office will handle testing submissions for both US and UK divisions, vendors are required to indicate for which market the samples need to be tested by labeling the box as either US, EU or US/EU for easy identification before sample dispatching.



Section - 4b (Wholesale)

Note: VENDORS MUST FOLLOW THE TESTING PROCEDURES AS OUTLINED IN THIS SECTION. FAILURE TO DO SO WILL RESULT IN VENDOR'S FULL ACCOUNTABILITY FOR THE DELAY OF TESTING SUBMISSION AND THUS SUBSEQUENT DELAY OF SHIPMENT.

Testing Costs

- For first time production sample testing, vendors are not required to pay any testing charge for any samples sent.
- Vendors are responsible for free submission of samples with sufficient quantity for testing.
- Vendors are also responsible for all shipping costs associated with the submission and return of testing sample (sample returns will be by request only).
- Vendors are fully responsible to pay for any fees associated with a failed test report and re-test charges should the first test fail due to proven vendors' mistakes including but not limited to the sample's inaccuracy, product non-conformity or defectiveness. Vendors are to follow the testing procedures as outlined in this section. Failure to do so will result in vendor's full accountability for the delay of testing submission and thus subsequent delay of shipment. PCHI reserves the right to penalize the vendors by air shipping the merchandise or chargeback the vendors for the loss of profit and from other losses resulting from product defects, product not complying with applicable standards, or product recall due to non-compliance with applicable voluntary or mandatory standards. (Please refer to Section 9, paragraph 13 for vendors' potential remedies required).

Approved Testing Lab Responsibilities

Receipt of Samples/ Samples On Hold

Approved testing lab shall notify the test requestor (PCHI's local office PSG (Product Safety Group) or the Vendor) when a test request is placed into an "on hold" status due to receipt of insufficient samples, or any other reason. If the local PCHI office PSG is the test requestor, vendors will be contacted by the local PSG to make resubmission. For purposes throughout this VSM, Approved Testing lab shall mean an independent third party testing laboratory that is approved by the US Consumer Product Safety Commission to conduct testing in accordance with CPSIA.

Testing of Samples

Conduct testing and evaluate products in accordance with PCHI testing protocol and mutually agreed practice to comply with applicable local, state and federal regulations. Approved testing lab will notify submitter prior to commencing testing if testing fees are estimated to exceed \$US 200.00, and will not proceed with testing in these cases without written approval from PSG requestor.

Reporting of Test Results

Approved testing lab will distribute the testing reports directly to sp.productreports@Amscan.com and the test requestor, i.e., Hong Kong PSG or USA PSG. Vendors will be notified of the result via e-mail by the test requestor, i.e., Hong Kong PSG or USA PSG.

Testing Lead Time

Under normal circumstances, products will be evaluated in accordance with the Test Protocols within five to seven working days based on the product type and testing required.

Under certain circumstances, it may not be possible to complete testing on an item within the established timeframe due to conditions inherent to specific test requests or due to the product itself (i.e. UL verification on an electrical product, or candles that have a claimed burn time of 200 hours).



Section - 4b (Wholesale)

In such cases the approved testing lab, prior to commencing testing, will provide an estimated completion time for the required tests.

PCHI Testing Protocols vary by each individual product and can vary by each style. Test Protocols are subject to change if the product varies from the initial product for which the Test Protocol was developed. Upon receipt of actual samples, it is at the laboratory's option to determine which, if any, additional tests are necessary and to notify the submitter of their recommendation. The laboratory shall receive written approval, from the test requestor, before commencing additional tests that may be necessary.

Test Results and Ratings

Each test report shall indicate the quantitative (numerical values, such as 90 ppm or 0.1 %) and qualitative (Pass/Fail, Comply/Does Not Comply, or equivalent) test result(s) for the parameters evaluated. The report shall also include an overall rating of the final report that is based on the following rating system:

Pass

The product meets all The Client requirements, including mandatory and voluntary standards, specified in the testing protocol.

Fail

The product does not meet all The Client requirements, including mandatory and voluntary standards, specified in the testing protocol.

For Informational Purposes Only

The product is not judged to pass or fail a specified test protocol, but is tested to determine the sample's performance relative to an industry standard.

Test Report Format

The following are the identifiable sections to an approved testing lab's test report:

Report Cover/ Executive Summary

The Report Cover gives an overview of the testing by showing the overall product rating (Pass, Fail, or For Informational Purposes Only) with a brief executive summary. The report shall then describe in detail each of the product's failed properties (if any) and any comments and/or recommended courses of action.

Protocol(s)

The Test Protocol(s) utilized for testing shall be attached with the report. The Test Protocol provides detailed information regarding the tests performed and the actual data recorded by the approved testing lab during testing.

Exhibit Page(s)

Exhibit pages are typically included with a report to show a failure. For example, if a toy failed a sharp edge test, then an exhibit page (picture) shall be included in the report showing the area of non-compliance. In cases of labeling or wording failures, Exhibit pictures shall be taken to document the exact wording and format of a product label.

Chart(s)

When appropriate, charts and/or graphs shall be included to show data in test reports.

Picture Page(s)

The last page of a test report shall contain a product image of tested item.



Section - 4b (Wholesale)

Sample Disposal/Return

Product testing is fully destructive. All samples are retained by the test laboratory for three months in the U.S. and one month in Hong Kong from the date of submission. Vendors can have samples returned to them provided they accept all costs for re-packaging and shipping and indicate return instructions on the Test Request Form at the time samples are submitted (if submitting directly to lab) or on the Sample Submission Form (accompanying the samples sent to the local PCHI office). Vendors are responsible for all shipping costs associated with the submission and return (by request only) of test samples. Neither PCHI nor the laboratory is responsible for product damage incurred as a result of shipping.

D. PRODUCT TESTING PROTOCOLS AND GUIDELINES

Testing Protocols

All production samples received by the laboratory shall be tested in accordance with an established PCHI Test Protocol which an approved testing lab can supply to the vendor for their specific product category. If at the time production samples are received, an PCHI Test Protocol does not exist, the laboratory will develop a Test Protocol within 2-3 working days. Additional time may be required for the development of Test Protocols under certain circumstances such as the research and ordering of standards.

Test Protocols are a compilation of various market (U.S., Canada, EU, etc.) regulations and industry standard requirements (i.e. tests) that the product must meet. Test Protocols will be issued by the approved testing lab and then approved for use by PCHI.

In addition, test protocols serve two primary purposes:

1. Provide information regarding what tests will be performed so vendors understand the expectations of PCHI for their products prior to testing. As some items may be slightly different, Test Protocols are to be used as a guideline only and are subject to change. A product-specific Test Protocol will be developed at the sample submission stage if necessary.
2. Test Protocols ensure consistency between laboratories around the world by providing instructions to the approved testing laboratories on what tests are required for specific PCHI products.
 - All production samples are to be tested in compliance with PCHI's safety protocol for that market, e.g. US Regulatory safety test to CPSIA, through submission to an approved testing lab.
 - PCHI's local office PSG will review all submitted production samples and determine all the appropriate tests with onward submission to an approved testing lab.
 - Should there be no appropriate test determined; the approved testing lab will provide a recommended evaluation subject to PCHI approval.
 - This final evaluation will be made based on product category, construction, materials, age grading, packaging and labeling review, and product safety requirements.
 - Vendors have the obligation to manufacture their products to meet PCHI specifications and all applicable U.S. regulatory safety test requirements for the markets in which the products will be used, including, but not limited to and as specified on the product specification or test request form, the United States, Canada and/or European Union (EU).

Section - 4b (Wholesale)

- Although product regulatory safety and quality tests vary from product to product, general compliance to the following safety regulations or regulatory body requirements is generally expected:
 - *CPSIA (Consumer Product Safety Improvement Act of 2008)*
 - *Canadian Consumer Product Safety Act (CCPSA)*
 - *Flammability*
 - *Flammable Fabrics Act*
 - *NFPA (National Fire Prevention Association)*
 - *NSF*
 - *Federal Trade Commission*
 - *ASTM International*
 - *Poison Prevention Packaging Act*
 - *Child Safety Protection Act*
 - *Consumer Product Safety Commission (CPSC)*
 - *Textile Fiber Products Identification Act*
 - *Federal Hazardous Substances Act (FHSA)*
 - *Federal Food and Drug Administration (FDA)*
 - *United States Department of Agriculture*
 - *United States Food, Drug and Cosmetic Act*
 - *California's Safe Drinking Water and Toxic Enforcement Act (Proposition 65)*
 - *Fair Packaging and Labeling Act (FPLA)*
 - *Uniform Packaging and Labeling Regulation (UPLR)*
 - *Underwriter Laboratories (UL)*
 - *Phthalate restrictions & bans – California Assembly Bill AB 1108*
 - *International Standards Organization (ISO)*
 - *American National Standards Institute (ANSI)*
 - *American Association of Textile Chemists & Colorists (AATCC)*
 - *United States Clean Air Act*
 - *California Air Resource Board for Formaldehyde in Composite Wood Products*
 - *Labeling of Hazardous Art Materials (LHAMA)*
 - *Coalition of Northeastern Governors (CONEG) Toxics in Packaging Clearinghouse (TCPH)*
 - *United States Pharmacopeia*
 - *Federal and State Mercury in Battery Regulations*
 - *Society of Glass and Ceramic Decorated Products*
 - *State and Federal Regulations for Bisphenol A Content*
 - *Canadian Hazardous Product and Labeling Acts*
 - *Victims of Trafficking and Violence Protection Act of 2000*
 - *California Transparency in Supply Chains Act of 2010*
 - *European Toy Safety Directive 2009/48/EC*
 - *EU REACH SVHC (Registration, Evaluation, Authorization and Restriction of Chemical substances, namely Substances of Very High Concern for Children's Products)*
 - *EU Timber Regulation EU 995/2010 for paper and wood products*
 - *Washington State Chemicals of High Concern to Children (CHCC)*
 - *Maine Toxic Chemicals in Children's Products*
 - *Oregon High Priority Chemicals of Concern for Children's Health*
 - *SEC Conflict Minerals Rule 17 CFR 240*
 - *16 CFR 1107 Testing & Labeling for Product Certification*
 - *Food Safety Modernization Act, including 21 CFR 117*
 - *RoHS Directive 2011/65/EU for electrics/electronics intended for Europe market*
 - *EC No. 1935/2004 for food contact items intended for European market*



Section - 4b (Wholesale)

Guidelines for Children's and Other Products

This appendix of this VSM contains *PCHI Guidelines for Children's and Other Products*, which can be used, along with PCHI product test protocols, to ensure compliance of vendor's item to all applicable local, state and federal safety regulations. The enclosed version is dated 3/17/16 and will be updated from time to time. Vendors will receive the updates, but are responsible for monitoring changes in regulations as they occur and taking necessary actions to ensure compliance with the most current regulations.

For purposes of compliance with North American regulations, the following definitions are used:

Children's Product: a consumer product designed or intended by the manufacturer primarily for children under 14 years of age.

Toy: a consumer product designed or intended by the manufacturer primarily for children under 14 years of age for use by the child when the child plays.

Child Care Article: a consumer product designed or intended by the manufacturer primarily to facilitate sleep or the feeding of children age 3 and younger, or to help such children with sucking or teething.

Toy That Can Be Placed in a Child's Mouth: applies to any part of a toy that can actually be brought to the mouth and kept in the mouth of a child so that it can be sucked or chewed. If a toy or any part of a toy in one dimension is smaller than 5 centimeters, it can be placed in the mouth.

Proposition 65: California, and possibly other states in the future, has additional requirements for lead, cadmium, arsenic, mercury, formaldehyde and phthalates in non-children's and other products that may exceed federal requirement. (please refer to <http://www.oehha.org/prop65.html> for more information about California's Proposition 65 requirements and refer to http://www.oehha.ca.gov/prop65/prop65_list/files/P65single120415.pdf for a recent list of Prop 65 chemicals. For example, lead in Cosmetics cannot exceed 5 ppm in California, where the federal limit is 10 ppm. Also, in California, lead in PVC Coated electrical Cords cannot exceed 300 ppm, where there is not currently a federal requirement for PVC coated cords.

Wherever a state requirement is more stringent than a federal requirement, PCHI requires compliance with the standard that meets both the state and federal requirements.

E. VENDOR QUALIFICATION & SOCIAL COMPLIANCE CERTIFICATION

Vendor Qualification

As part of PCHI's commitment to product quality and safety, new or potential suppliers need to be qualified to conduct business with PCHI. Prior to issuance of a purchase order, PCHI personnel will conduct a qualification survey on the following areas:

1. Business Information
2. Management & Personnel
3. Factory Facilities for Design and Manufacturing (Good Manufacturing Practices)
4. Quality Management System
5. Social Compliance Evaluation
6. Qualitative Evaluation for Management & Personnel



Section - 4b (Wholesale)

7. Design and Manufacturing Capability
8. Process and Product Quality Control
9. Final Product Traceability
10. Observations of Critical Factory Areas

The results of this survey will be reviewed with personnel from Product Management, Sourcing, and the applicable business units within PCHI to determine the viability of new vendors.

Vendor Certification for Social Compliance

As part of PCHI's commitment to responsible and ethical business practices, all PCHI suppliers shall provide a socially compliant work environment. PCHI requires its suppliers to comply with applicable local laws and the principles put forth by its customers, e.g., Disney, Mattel, Wal-Mart, or equivalent, in the following areas and summarized in PCHI's Supplier Code of Conduct referenced in Section 10 and enclosed in the Appendix of this VSM:

- Management Systems
- Child Labor
- Forced Labor
- Health & Safety
- Freedom of Association and Collective Bargaining
- Non-Discrimination
- Immigration Law Compliance
- Disciplinary Practices
- Harassment & Abuse
- Compensation & Benefits
- Hours of Work
- Environmental Compliance
- Customs Compliance
- Security
- Sub-Contracting
- Homework

A Certification Audit (done by independent, 3rd Party Auditing firm **such as Intertek, SGS, Bureau Veritas or Elevate**) that incorporates the standards of the applicable retail customer, license brand or other 3rd party in these areas will be requested, conducted and/or verified, as applicable, from time to time. Resolution of all corrective actions, as well as the cost of repeat audits necessary for compliance or to receive certification, will be the responsibility of the vendor. For purposes of a licensing program, audits are deemed to be current if they have been done within the past calendar year.



Section - 4b (Wholesale)

CPSIA and Safety Requirement Guidelines Acknowledgement

The Consumer Product Safety Improvement Act of 2008 (CPSIA) changed the safety requirements of many items sold by PCHI. As part of PCHI's commitment to fully comply with CPSIA, it is mandatory that products supplied to PCHI by its vendors covered under the Consumer Product Safety Improvement Act of 2008 (the Act) be in compliance with all requirements of this legislation. This includes, but is not limited to, the following areas of the Act:

- Children's products containing lead and the lead paint rule. (Title I – Section 101 of the Act)
- Mandatory third party testing for certain children's products and certification requirements. (Title I – Section 102 of the Act)
- Tracking labels for children's products. (Title I – Section 103 of the Act)
- Labeling requirements for children's toys and games, and the vendors obligation to provide the necessary cautionary statement information required by the Act. (Title I – Section 105 of the Act)
- Mandatory toy safety standards. (Title I – Section 106 of the Act)
- Prohibition on sale of certain products containing specified phthalates. (Title I – Section 108 of the Act)

Food and Products that come into contact with Food

Vendors that supply PCHI with food and products that come into contact with food are required to comply with all U.S. FDA (Food and Drug Administration) regulations, [the Food Safety Modernization Act \(FSMA\), U.S. FDA CFR Title 21, including but not limited to Part 117, and Proposition 65 regulations](#). For those facilities that produce food, the following documentation, with satisfactory result(s) is required, but not limited to: i) factory contact & address, ii) GMP food facility certification audit, or equivalent, iii) product test report(s) in accordance applicable test protocols, iv) packaging claims and independent, third party substantiation, v) certificate(s) of insurance, vi) product and process inspection plan in accordance with FDA or equivalent methodology, vii) current social compliance audit per PCHI Code of Conduct requirements, viii) current FDA bioterrorism registration certificate, and ix) applicable country certification(s) required by local or national law.

Certification and Testing Documentation

Vendors must certify (with a GCC as applicable) based on a test of each product they supply PCHI or upon a reasonable testing program that all product that PCHI purchases complies with all rules, bans, standards, or regulations applicable to that product under the Consumer Product Safety Act of 2008, any other Act enforced by the Consumer Product Safety Commission (CPSC), and all U.S. FDA Codes of Federal Regulations (CFR).

If revisions to this Act, other CPSC Acts, U.S. FDA CFR's, or future consumer safety legislation or regulation results in additional or alternate safety requirements, PCHI's vendors are required to meet those standards. This includes, but is not limited to, requirements specified in this Vendor Standards Manual and state regulations of Proposition 65, CONEG Toxics in Packaging regulations, or any other applicable laws.

To acknowledge your receipt of this VSM's Product Safety and Quality Assurance requirements, please indicate which PCHI entity you are supplying, sign and date this document to certify that all products you supply to the PCHI entity are in compliance, and will continue to be in compliance in the future, with the Consumer Product Safety Improvement Act of 2008, other Consumer Product Safety Commission Acts, and all applicable U.S. FDA or state regulations. Please return a copy of the signed and dated document to the fax number of the applicable PCHI entity representative. (All PCHI entity contacts are listed in Section 11 of this Vendor Standards Manual).

For your reference, Guidelines for Children's and Other Products is enclosed in the appendix.



Section - 4b (Wholesale)

State Chemicals in Children's Products

There are certain chemicals which have notification and/or regulatory requirements for the states of Maine, Oregon, Vermont, New York and/or Washington in the United States. If your product(s) contain chemicals from the PCHI Chemical List (last updated on 2/1/2016, made available on Amscan's Vendor Portal, and updated from time to time) that are **unintentionally** added to children's products above the Practical Quantitation Limit (PQL), which, for practicable purposes, is 100 ppm (0.01%), please inform PCHI of the chemical name and amount by weight of the chemical in the product. [Please note that the PQL is based on the test methodology used for chemical detection]. If you have testing done to levels below 100 ppm for any chemicals on the PCHI Chemical List that are **intentionally** added, then please inform us of the level to which the chemicals are being measured and the level of the chemical.

Some chemicals with a check mark on the PCHI Chemical list for SVHC also have a check mark for Maine, Oregon, Vermont, New York and/or Washington State. These chemicals, if present, need a corrective plan to find a suitable replacement. Note that Lead (Pb), Cadmium (Cd), Arsenic (As), Antimony (Sb), Mercury (Hg), Bisphenol A (BPA), Formaldehyde, and Phthalates DBP, DEHP(DOP), BBP, DINP, DNOP, DIDP, DIOP, DIBP, DPP(DPENP), DNHP(DHEXP), DCHP, DEP, and MBP (CAS#131-70-4) do not require notification since a control program as stated in this Vendor Standards Manual ("VSM") and PCHI's Guidelines for Children's and Other Products is in place to ensure that the products you supply to PCHI and its affiliated companies comply with applicable local, state, and federal regulations for these chemicals. For example, Lead in surface coating and substrate needs to be under 40 or 90 ppm, depending upon product category, and under 1 microgram using the NIOSH 9100 test according to California Proposition 65 regulations, Phthalates need to be under 1000 ppm (0.1%), and total Cadmium needs to be under 75 ppm.

CFR 1107

As part of US federal regulation 16 CFR 1107 requirements effective February 8, 2013 for children's items, PCHI needs to ensure that all items comply with applicable regulations.

In addition to the current periodic production testing, GCC or CPC, and random sampling that PCHI is already doing with your cooperation, please ensure the following:

1. You inform PCHI of any significant changes in materials, factories, processes, designs, or construction for children's items that you manufacture for PCHI. A sample Product Change Notice (PCN) form is enclosed in this section for your use or reference.
2. Your company has on file, and viewed by all, a written policy statement from a company officer stating that the exercise of undue influence on third party conformity assessment bodies is not acceptable, a letter to all appropriate staff members to receive training on this policy, and a signed statement attesting to their participation in such training.

If there are any reports of alleged undue influence, please investigate immediately and inform PCHI as soon as possible. If you have any questions on the requirements of 16 CFR 1107 or your obligations to PCHI, please contact us immediately.



Section - 4b (Wholesale)

CPSIA and Safety Requirement Guidelines Acknowledgement

If you have any questions, please contact the respective representative of PCHI's entity anytime.

PCHI Entity _____

Vendor Signature _____

Printed Name _____

Title _____

Company Name _____

Date of Signature _____

Please refer to *PCHI Guidelines for Children's and Other Products* on the website for a summary of specific product safety requirements (Vendor Compliance Guidelines - Wholesale PDF).

All wholesale vendors in Asia that ship to Amscan must complete and email this acknowledgment form to Cherry Yuen, Senior Product Development & Merchandising Manager at cyuen@amscan.asia or fax to 011-852-2155-1511.

All wholesale vendors in Asia that ship to Grasslands Road must complete and email this acknowledgment form to Winnie Sze, Merchandising Manager at wsze@amscan.asia or fax to 011-852-2155-1511.

All wholesale vendors in Asia that ship to Anagram International must complete and email this acknowledgement form to Helen Phillips, Quality Manager at hphillips@anagramintl.com or fax to 952-949-6470.

All wholesale vendors in North and South America that ship to PCHI must complete and email this acknowledgment form to vendorrelations@amscan.com or fax to 914-784-4302.

All Bypass and Full Case vendors that ship to an Amscan Entity must complete and email this acknowledgment form to vendorrelations@amscan.com or fax to 914-784-4302.



GENERAL CERTIFICATE OF CONFORMITY FOR CONSUMER PRODUCTS

CERTIFICATE DATE:

CERTIFIED BY:

MANUFACTURER NAME:

ADDRESS:

CITY:

STATE/PROVINCE:

COUNTRY:

PHONE#:

Importer: (Name, Address & Phone #)
PCHI Inc. 80 Grasslands Road Elmsford, NY USA 914-784-1910
Importer: (Record Keeping Contact)
VP - Product Safety 80 Grasslands Road Elmsford, NY USA 914-784-1910 minzalac@Amscan.com

Item Number	Item Description	Vendor Number	Purchase Order #	Date of Manufacture (Month/Year)	Place of Manufacture (Factory Name, Address & Phone #)	Testing Date (Month /Year)	Place of Testing/ Third Party Testing Lab (Name, Address & Phone #)

In accordance with Section 14 of the Consumer Product Safety Act, 15 U.S.C. 2063(a), the manufacturer certifies that based upon a test or a reasonable test program, the product listed above complies with all applicable consumer product safety rules, bans, regulations or standards under the Consumer Product Safety Improvement Act (CPSIA) of 2008 or any other Act enforceable by the United States Consumer Product Safety Commission, as indicated in Table 1 below (check all that apply):

Check All
That Apply
Products)

Table 1: Consumer Product Safety Rules (Children's & Other Applicable

- | | | |
|--------------------------|--|-----------------------|
| <input type="checkbox"/> | Lead in Surface Coating (Children's Product) | 16 CFR 1303 |
| <input type="checkbox"/> | Lead in Substrate (Children's Product) | CPSIA 101 |
| <input type="checkbox"/> | Lead in Children's Metal Jewelry | CPSIA 101(a)(2) |
| <input type="checkbox"/> | Choking Hazard Labeling (Children's Product) | 16 CFR 1500.19 |
| <input type="checkbox"/> | Pacifiers (Children's Product) | 16 CFR 1511 |
| <input type="checkbox"/> | Rattles (Children's Product) | 16 CFR 1510 |
| <input type="checkbox"/> | Children's Products with Liquids | 16 CFR 1500.14 |
| <input type="checkbox"/> | Toys (ASTM F963) | CPSIA 106 |
| <input type="checkbox"/> | Flammability of Solids (Children's Product) | 16 CFR 1500.44 |
| <input type="checkbox"/> | Flammability of Textiles (Adult & Child) | 16 CFR 1610 |
| <input type="checkbox"/> | Flammability of Plastic Film (Adult & Child) | 16 CFR 1611 |
| <input type="checkbox"/> | Phthalates in Toy & Childcare Items | CPSIA 108 |
| <input type="checkbox"/> | Art Materials (LHAMA) | 16 CFR 1500.14(b) (8) |
| <input type="checkbox"/> | Other (please specify) <input type="text"/> | <input type="text"/> |
| <input type="checkbox"/> | Other (please specify) <input type="text"/> | <input type="text"/> |

"NOTE: Manufacturer shall email this WORD document using the naming format: **Item#_Vendor#_Certificate Date with MMDDYYYY** (For example, item 123456 from vendor number 999 made on November 12, 2008 would be 123456_999_11122008.doc) to the following distribution: sp.gcc@Amscan.com

PRODUCT CHANGE NOTICE
(CHILDREN'S PRODUCTS)

DATE:

MANUFACTURER NAME:

ADDRESS:

CITY:

STATE/PROVINCE:

COUNTRY:

PHONE#:

	Importer: (Name, Address & Phone #)
	Importer: (Record Keeping Contact)

Item Number	Item Description	Vendor Number	Purchase Order #	Date of Manufacture (Month/Year)	Place of Manufacture (Factory Name, Address & Phone #)

In accordance with 16 CFR 1107 Testing and Labeling pertaining to Product Certification the manufacturer, in accordance with requirements put forth by United States Consumer Product Safety Commission, is informing Party City Holdings Inc. of the following significant product changes:

Check All That Apply

PRODUCT CHANGE: CHILDREN'S PRODUCTS

- MATERIALS (Change in Bill of Materials for a child item or its components)
- FACTORY (Change in manufacturing location for a child item or its components)
- PROCESS (Change in the way the child item or its components are produced)
- DESIGN (Change in size, shape, color, or functionality of the child item or its components)
- CONSTRUCTION (Change in how the child item or its components are assembled or put together)

Upon receipt of an item's Product Change Notice (PCN), a more detailed inquiry will be undertaken by PCHI as needed.

"NOTE: Manufacturer shall email this WORD document using the naming format: **Item#_Vendor#_PCN_Date with MMDDYYYY** (For example, item 123456 from vendor number 999 made on February 9, 2013 would be 123456_999_PCN_02092013.doc) to the following distribution: hchen@amscan.com and minzalac@amscan.com



GENERAL CERTIFICATE OF CONFORMITY FOR CONSUMER PRODUCTS

CERTIFICATE DATE:	
CERTIFIED BY:	Anagram International
MANUFACTURER NAME:	
ADDRESS:	
CITY:	7700 Anagram Drive Eden Prairie, MN 55344
STATE/PROVINCE:	
COUNTRY:	USA
PHONE#:	952-949-5600

Item Number	Item Description	Date of Manufacture (Month/Year)	Place of Manufacture (Factory Name, Address & Phone #)	Testing Date (Month/Year)	Place of Testing/ Third Party Testing Lab (Name, Address & Phone #)

In accordance with Section 14 of the Consumer Product Safety Act, 15 U.S.C. 2063(a), the manufacturer certifies that based upon a test or a reasonable test program, the product listed above complies with all applicable consumer product safety rules, bans, regulations or standards under the Consumer Product Safety Improvement Act (CPSIA) of 2008 or any other Act enforceable by the United States Consumer Product Safety Commission, as indicated in Table 1 below (check all that apply):

Check All That Apply Products)

Table 1: Consumer Product Safety Rules (Children's & Other Applicable

- | | | |
|--------------------------|-------------------------------------|---|
| <input type="checkbox"/> | Lead in Surface Coating | 16 CFR 1303 |
| <input type="checkbox"/> | Lead in Substrate | CPSIA 101 |
| <input type="checkbox"/> | Choking Hazard Labeling | 16 CFR 1500.19 |
| <input type="checkbox"/> | Toys (ASTM F963) | CPSIA 106 |
| <input type="checkbox"/> | Flammability of Solids | 16 CFR 1500.44 |
| <input type="checkbox"/> | Phthalates in Toy & Childcare Items | CPSIA 108 |
| <input type="checkbox"/> | Other (please specify) | <table border="1" style="width: 100%; height: 20px;"></table> |
| <input type="checkbox"/> | Other (please specify) | <table border="1" style="width: 100%; height: 20px;"></table> |



Section 5 – Wholesale

Imports

Overview

PCHI (Party City Holdings Inc) is a worldwide importer and seeks to follow international trade guidelines. Due to the complex routing and documentation procedures of Imports, PCHI encourages vendors to read and follow instructions thoroughly. Note shipping guidelines are generalized and may vary with each vendor, country of origin, or PO. Contact the designated PCHI Logistics team with any questions. Refer to the PCHI Logistic team charts within this section for contact information. Please note, with the merger of Amscan Inc. and Party City, many of the Party City vendors will now be ordered through Amscan or Anagram International. We appreciate your cooperation in complying with the standards established for PCHI's Import program.

Review all sections in the Import section, as it thoroughly explains the documents required and when each must be forwarded to various designated parties.

ISF

US Customs and Border **Protection** has implemented a new initiative called ISF (Importer Security Filing; also referred to as 10+2. US Customs requires the following ten data elements to be sent electronically to them before the container is allowed to be loaded aboard a vessel. The information must be transmitted to US Customs electronically 48 hours before loading; therefore, the information must be furnished to the PCHI designated forwarder 5 working days before the freight is available for pick up at your location. PCHI will furnish #7 and #8 **directly to the forwarder. #10 will be on the purchase order.**

1. Manufacturer Name and Address: the last factory to 'finish' the goods
2. Seller Name and Address: last known entity by whom the goods are sold
3. Buyer Name and Address: last known entity by whom the goods are **purchased**
4. Ship To Name and Address: name **and address** of first delivery
5. Container Stuffing Location Name and Address: physical location where the container was stuffed
6. Consolidator Name and Address: the party who arranged the stuffing
7. Importer of Record Number: Amscan or Anagram International IRS#
8. Consignee Number: who's account merchandise is shipped
9. Country of Origin: where the goods were made
10. HTS#: require up to the 6th digit of the HTS for each item

Steamship lines will be required to furnish these next two items:

1. Vessel Stow Plan: Customs will require this 48 hours after departure
2. Container Status Message

US Customs has begun assessing penalties of \$5000 per incident for filings that **are untimely or** have incorrect or missing information. PCHI will not be responsible for any penalties due to a vendor's late filing. If this does occur, vendors will be assessed in the amount of the penalty along with a \$500 additional charge.

General Conformity Certificate (see section 4 for more information and forms)

In accordance with the new laws put forth by the Consumer Product Safety Improvement act of 2008 (CPSIA) a General Certificate of Compliance (GCC), also referred to as a Children's Product Certificate (CPC) for products intended for users under 14 years old, will need to be provided with shipments of toys and children's items, and other applicable products, such as wearing apparel, lighters, art materials, etc., regulated by the CPSC, that are manufactured after November 11, 2008. (GCC form is at end of this section and in section 4). For PCHI, the certificate applies mostly to children's products that are primarily intended



Section 5 – Wholesale

for use by children 14 years of age and under, but there are some other product categories that fall under the jurisdiction of the Consumer Product Safety Commission, such as wearing apparel and art materials. Items requiring the GCC will be specified on our purchase orders.

The GCC is verification that an item has passed the required tests for the US market, which are currently done when you send production samples to PCHI's local office for test submission or directly to the lab for testing. On the applicable items, a PASS test report will need to have been received or verified, and the GCC completed, before shipping the item.

The GCC needs to be submitted with the shipping documents and a copy must also be sent via email to the PCHI database at the email addresses listed at the bottom of the GCC document. The email certificate may be sent as soon as a "Pass" test report is either received or confirmed by the local PCHI office. It is important to have the certificate and pass test report confirmations before shipment since PCHI's brokers will not accept the booking without the proper GCC. PCHI can accept prior test reports as evidence as long as:

- 1) the materials, design, processes and factory are the same for the items sent to Amscan as the production sample(s) that were submitted for testing within the past year, and
- 2) the test report(s) contain all applicable tests in accordance with a reasonable test program. For example, toys were tested for phthalates, ASTM 963, and **lead and other heavy metals** in surface coatings & substrates.

PCHI purchases international shipments via the below INCO Terms:

1. Free on Board (FOB) (CY-CFS-By Pass or EDC)

Vendors are responsible for delivery to PCHI's designated freight forwarder or one of three contracted direct ocean carriers. PCHI is responsible for import freight costs and customs clearance and takes possession of goods upon Forwarder Cargo Receipt (FCR) issuance. This includes full container loads, less than container load (LCL), cargo, air, and ocean shipments. Vendor is to contact the designated PCHI Logistics Import team for local forwarder/ocean carrier information. Any deviation from the policy will result in the reimbursement charges.

Air shipments, where PCHI is responsible only for the ocean charges, will be calculated based on the applicable rates for container shipments on the date of the shipment. Calculations based on LCL rates or carton dimensions are not acceptable.

The PCHI designated company Import team is responsible for all charges before the PO is shipped. No charges will be paid unless vendors seek approval from the Import team in advance. All approvals must be in writing or email.

2. Delivered Duty Paid (DDP) Delivered to DC

Vendors are responsible for delivery to the PCHI Distribution Center door, including all freight costs, duties, and customs clearance under vendor's own importer of record number. PCHI takes possession of goods upon receipt at our DC locations.

3. Landed Duty Paid (LDP)

Vendors are responsible for delivery to the port of entry, which can include the terminal railhead located nearest to the PCHI DC destination. LDP includes all freight costs and customs clearance under the vendor's own importer of record number. PCHI takes possession of the goods after clearing customs.

For LDP shipments the vendor is responsible for all labeling and EDI as outlined in this Vendor Standards Manual.



Section 5 – Wholesale

Import Shipping/FOB

1. All terms are FOB **Port or PCHI nominated CFS**. The PCHI Logistics Import team will nominate a forwarder/consolidator/ocean carrier for all shipments. Location will be listed on the PO. Instructions will be given once country of origin and port of loading is confirmed.
2. Any shipper not delivering cargo to the designated consolidator/forwarder, or not contacting the nominated ocean carrier, will be assigned a penalty and will be considered a DDP shipment. Please refer to the Reimbursement and Waiver Policy, Section 8.
3. Merchandising/Product managers may not change/assign routing or change INCO terms. All requests for changes to routing or terms for carriage must be sent to the designated PCHI Logistics Import Manager or Vice President of Transportation and Supply Chain in writing at least **fifteen (15)** business days prior to the vendor ship date.
4. PCHI will utilize our forwarders order management system for all shipments. Vendors must participate in the program to insure compliance with ISF filings and other US Customs regulations. All Factory loads are to be made through the PCHI designated freight forwarder using their order management system. Vendors must seal factory container loads using industry standard seals. All loads must not exceed the U.S. weight restrictions. All LCL loads will also be managed through our designated forwarder utilizing the order management package to insure compliance. In the future, shipment booking will be required to be completed on-line through our designated forwarder's portal.
5. In the future, all factories will be required to be Customs-Trade Partners Against Terrorism (C-TPAT) certified. Notifications will be done by the designated PCHI Logistics Import team.
6. Containers must meet Cubic Meter (CBM) minimum requirements. All LCL shipments require written approval from the designated PCHI Logistics Import team. Vendors are financially responsible for under-utilized containers based on minimum CBM requirements as listed below.

Container	Cubic Meter
20 (TEU)	28 CBM
40 (FEU)	58 CBM
40H (FEU)	65 CBM
45 (FEU)	68 CBM
48 (FEU)	72 CBM

7. Vendors must strictly adhere to consolidation cut-off times and check with the specified consolidator or carrier's office in advance if a "late gate" is needed. If cargo does not make the designated vessel's departure and is outside of the PO ship window, the Product Development Manager or P&A Manager may request a routing change from the Import team or cancel the PO. All additional freight costs and penalties will be at the vendor's expense. Penalties and reimbursements are defined in the Reimbursement and Waiver Policy.
8. All loads must ship from original country of origin.
9. Failure to comply with **SOLAS, documentation or** marking requirements will result in a deduction of full expenses incurred by PCHI, or our third parties, to meet import requirements.
10. In addition to the labeling requirements outlined in the Packaging and Packing, Section 3B (unless specifically waived by PO), every carton must be clearly marked with the following information (Customs requirements):



Section 5 – Wholesale

- Country of Origin
- PO#
- Model and SKU or Item Number
- Quantity
- **Weight**

11. Cartons with shippable inner quantities must be marked 'Re-Pack' with a bright label. Additionally, each inner carton must have the following information (Customs Requirements):

- Country of Origin
- PO#
- Model and SKU or Item Number
- Quantity
- **Weight**

FOB Import Document Path

1. Vendors must place booking at least ten business days prior to the required ship date with the PCHI designated Consolidator/Forwarder/Ocean carrier.

Note: Vendors must provide the following information to the designated freight forwarder at the time of booking; otherwise, booking will not be released:

- Shipper's name
 - Shipper's full address
 - Consignee name
 - Detailed commodities description (no generic description)
 - Harmonized Tariff Number (HTS #)
 - Destination
 - Carton count, quantity in carton, weight, and measurement
 - Country of origin
 - Commercial invoice
 - Final packing list
 - General Certificate of Conformity for Children's Products
2. The Consolidator/Forwarder/Ocean carrier will issue an original Forwarder's Cargo Receipt (FCR) or Express BOL in return for surrender of appropriate documents and cargo. The FCR will NOT be issued unless all required documents are presented.
3. All original documents and a four-copy set must be surrendered to the consolidator/forwarder at the time the cargo is surrendered or no more than **three (3)** business days after cargo is tendered. Failure to comply will result in reimbursement charges as defined in the Reimbursement and Waiver Policy.
4. All shipments will be given a **Forwarder's Cargo Receipt** or an express Bill of Lading unless previously authorized. Only when authorized by PCHI, will the consolidator/forwarder prepare an original Ocean Bill of Lading (OBL) or allow the OBL to be used as the negotiable instrument. Shippers will NOT be given an OBL by the consolidator unless authorized by PCHI's Logistics Import team.
5. VISA documents may not be available at the time of booking due to some countries' export procedures. Proof must be furnished that the quota is available to the shipper at time of booking. However, a document verification certificate or a cargo receipt will NOT be issued until the designated PCHI Logistics Import team verifies the actual VISA documents. It is required the VISA document be supplied prior to the shipment arriving at the first U.S. port of discharge, or costs for storage will be deducted from the shipper's remittance.

VISA and/or Special Documents Required For Specific Items

In addition to general procedures and documents, some products are subject to special import restrictions, permits, licenses, standards, and/or procedures. To the best of our knowledge, below are the subject products PCHI may be importing:

Apparel or items containing textile

- Original VISA stamped document
- Manufacturer's Textile Declaration with authorized signature
- Denim Exclusion Statement for woven cotton garments on manufacturer's stationary with authorized signature
- Down detail statement-for items with down
- Certificate of Origin showing full name and address of the factory
- **General Certificate of Conformity**

Children's Products

- General Certificate of Conformity **or Children's Product Certificate (CPC)**

Art Materials

- General Certificate of Conformity

Wearing Apparel **(see Apparel section above)**

Composite Wood Products

- Chain of custody documentation which certifies use of compliant raw materials in accordance with the requirements of the California Air Resource Board (CARB) Airborne Toxics Control Measure (ATCM). This includes current Factory Certification at time of PO and production and product testing results, both showing compliance for formaldehyde emission.
- Lacey Act/APHIS information must be completed on the Plant and Plant Product Declaration Form
- **General Certificate of Conformity**

Footwear

- Interim footwear invoice
- Foxing or Foxing-like band
- Identity material of uppers
- Identify material of sole
- Open or closed shoe
- **General Certificate of Conformity**

Citronella Candles

- Lab report certifying that TSCA standard has been met and candle contains 3% or more of citronella content
- **Minimum risk pesticide certificate**
- **General Certificate of Conformity**

Leather items, leather shoes, parts, and finished leather footwear

- Manufacturer's statement of "PCP" free declaration

Radio Items

- FCC Form 740

Eye Wear Products and Sunglasses

Eyewear vendors need to provide the following documents along with the other shipping documents already provided, for example commercial invoice & packing list. Note that two documents (denoted by ***) are the same for both Sunglasses and Novelty Eyewear:

Section 5 – Wholesale

SUNGLASSES - Non-Exempt (Child & Adult) – 3 Documents

- Registration Number of Manufacturer & Device Listing Number of product(s) that are on the Bill of Lading (see RegList.pdf example within Appendix)
- Impact Resistant Drop Ball Test Certification (see IRC-1460.pdf within Appendix) ***
- Copy of 3rd Party Test Report for **UV claim and** Impact test in accordance with 21 CFR 801.410 and description of sampling plan rationale (Typical test required by AmScan) ***
- **General Certificate of Conformity**

NOVELTY EYEWEAR - Exempt (Child or Adult; Child item is age graded under 14 yrs) – 3 Documents

- Impact Resistant Drop Ball Test Certification (see IRC-1460.pdf within Appendix) ***
- Copy of 3rd Party Test Report for Impact test in accordance with 21 CFR 801.410 and description of sampling plan rationale (Typical test required by AmScan) ***
- Photocopy of a picture that clearly shows the *eyewear packaging with the following statement:*
"**Δ! WARNING: These glasses are intended for novelty use only. Not designed to provide medical benefit or protect eyes from impact and UV rays. Please retain this information for future use.**"
- **General Certificate of Conformity**

Identify each photo with the item number that is on the bill of lading.

Please email to SP.AHI-FDA-IRC@amscan.com for each Non-Exempt item and shipment the following documents, as applicable:

- Registration Number of Manufacturer & Device Listing Number of product(s) that are on the Bill of Lading (see RegList.pdf enclosed)
- Impact Resistant Drop Ball Test Certification (see IRC-1460.pdf enclosed)

Items made of **natural or vegetable material; i.e., bamboo, straw, rattan, etc.**

- Certificate of Fumigation
- **Lacey Act Declaration**
- Items made of wheat or rice straw are **not acceptable**

Feather and Shell Products

- U.S. Fish and Wildlife Service Permit **or CITES if applicable**
- The following information must appear on the commercial invoice **or self-declaration letter:**
 - Common Name
 - Scientific Name (genus and species)
 - Number of piece
 - Value of the **product**
 - Country of Origin
 - Source (wild **or farm raised**)
- **Certificate of Fumigation**

Chemical substances; i.e., resins, dyes, glues, ink, paints, etc.

- TSCA certificate signed by manufacture's shippers stationary with authorized signature
- Lab report certifying TSCA standard has been met

Wood packing materials and other unmanufactured wood products; i.e. wood crates **are NOT ACCEPTABLE**

- Shipments must certify that no solid wood packing material is present. The certifying statement, "THIS SHIPMENT CONTAINS NO SOLID WOOD PACKING MATERIAL", must be placed on company letterhead and Invoice and/or Bill of Lading.

Bamboo products, treated decorative wood items, wood turning planks, etc.

- Fumigation Certificate or Phytosanitary Certificate



Section 5 – Wholesale

PEACOCK FEATHERS

Any items containing components of peacock feathers are not allowed to deliver without the presentation of the certificate to prove feather type and farm source of origin. Self-Declaration letter is to contain this information:

- Amscan PO number
- Item Description
- Quantity
- Delivery Date
- Material Genus and Species
- Scientific Name
- Country of Origin
- Manufacturer of the material
- Cites Report

Items containing Peafowl (peacock) feathers are not allowed to deliver without a CITES report. If items get caught by custom at destination without Cites report, items will be confiscated and trashed with all cost incurred in the process to chargeback to vendors.

- Lacey Act Declaration

As a willing to the Department of Agriculture Act of 1990, as amended, and a person is required to ensure the accuracy of information used in filing a self-declaration number. The self-declaration number for this information collection 000-990-999. The time required to complete this information collection is estimated to average 0.5 hours per shipment including the time for reviewing instructions, searching existing data sources, gathering and maintaining the data needed, and completing and reviewing the collection of information. ONE A PROVED 7/17/2009 5:00 PM

SECTION 1 - Shipment Information

1. ESTIMATED DATE OF ARRIVAL (MM/DD/YYYY)
2. PO/PI NUMBER
3. CONTAINER NUMBER <input type="checkbox"/> In Attachment
4. BILL OF LADING
5. NITD

Plant and Plant Product Declaration Form

Section 2 Lacey Act Amendments (16 U.S.C. 3372)



U.S. DEPARTMENT OF AGRICULTURE
ANIMAL AND PLANT HEALTH INSPECTION SERVICE

6. DESCRIPTION OF WAREHOUSE

6. IV PORTER NAME
7. IMPORTER ADDRESS
8. CONSIGNEE NAME
9. CONSIGNEE ADDRESS

SECTION 2 - Compliance with Lacey Act Requirements (16 U.S.C. 3372(f))

For each article or species of an article, provide the following:							
11. HSUS NUMBER (as defined by book)	12. ENTERED VALUE	13. ARTICLE/COMPONENT OF ARTICLE	14. PLANT SCIENTIFIC NAME (Genus)	15. COUNTRY OF ORIGIN	16. QUANTITY OF PLANT MATERIAL	17. UWR	18. FUR LWI RECYCLED

I certify under penalty of perjury that, to the best of my knowledge and belief, the information furnished is true and correct.

Version 04/5/07, 1-0100
PROPOV 525
AUGUST 2011

Name (Last, First, Middle Initial)	Title	Signature Date	Unit

Page 1

Production control

As shipments were constantly seen with visible mold growth at the arrival of our DC warehouse, we require vendors to implement an effective mold prevention plan at the manufacturing facility to reduce the risk of mold development to the products. Moldy products cannot be sold since they are of poor quality and undermine our branding in retail. Most importantly, some types of mold can create health risks in certain individuals. As a result, moldy products will be destroyed at a cost chargeback to vendors. Loss chargebacks will include but are not limited to cost of goods sold, freight, handling and disposal cost, lab fees and loss of sale.

Vendors should always maintain the production facility dry and clean as moisture is the determining factor for mold growth. Any vendors producing items with the use of highly hygroscopic materials as below should stay more vigilant to the production process with best practices to start with material receiving / storage / manufacturing / packaging / finished goods storage and through shipment loading to containers.

- High Risk Items:
 - Wood / MDF
 - Flocked materials, fabric/paper/textile glue laminated products
 - Natural materials (natural rubber/natural down and feathers /real straw)
 - Denim materials treated with washing and bleaching
 - Products containing artificial fibers
 - Real leather or suede / imitation leather / suede in PU
- Production Check Points:
 - Incoming Material upon receiving
 - Unload materials in a clean and dry area
 - Visually check materials for cleanliness and moisture and use moisture meter to check moisture content
- Material storage:
 - Store materials in a clean, indoor room with the relative humidity below 60%
 - Do not store materials directly on the floor even temporarily
 - Materials must be stored on shelves or non-wooden pallets
- Production:
 - Production areas must be clean and dry with proper ventilation
 - To keep production area free from moisture and contamination, separate the production areas that include water/wet processing (such as painting, electroplating) from other production / packaging and storage areas
- Packaging:
 - Do not pack products when still warm from production
 - Glue and paint must be fully cured and dry prior to packaging, not just dry to the touch
 - Check moisture content of corrugated or cardboard material prior to use
 - Avoid recycled corrugate, which is prone to absorb moisture more than new materials
 - Regardless of corrugate type, moisture content should be between 12% - 13%. Do not use if above 15%
 - Use effective package desiccants with proper dosage to absorb moisture
- Products/Finished goods storage:
 - Maintain a clean dry finished-goods warehouse
 - Control the relative humidity in the warehouse with an air conditioner or dehumidifier
 - Never store finished goods outside, even under a roof or cover
- Loading and Shipping – before loading the container/enclosed truck:
 - Visibly check to ensure the roof is clean and undamaged and there are no holes or cracks in walls, floors or roof. Reject the container if any damage is found



Section 5 – Wholesale

- Use a moisture meter to check the moisture content of the wooden deck of the container/truck. Reject if the moisture content exceeds 25%
- Check cargo for visible moisture before loading and pull product randomly to check for the moisture content with a moisture meter
- Only load in dry conditions or under a roof that does not leak
- Keep the loading area dry and clean
- Avoid loading in the rain or fog

Bill of Lading

Vendors are required to follow the instructions below regarding the proper information for the Bill of Lading:

1. **Port of Discharge:** East Coast shipments should reflect the unloading port as defined by the PCHI forwarder.
2. **Place of Delivery:** East Coast shipments should match the final destination on the purchase order.
3. **Commodity:** Typically use "party favors and decorations"; some vendors may use "kitchenware", "ceramic mugs", "vinyl sheeting", etc. For further details, contact the designated PCHI Logistics team.
4. **Consignee:**

Amscan 80 Grasslands Road Elmsford, NY 10523	-OR-	Anagram International 5300 West 76th Street Edina, MN 55439
---	------	---
5. **Notify Party:** Designated forwarder information as confirmed prior to shipment from the designated PCHI Logistics Import Team.

Commercial Invoice

The Commercial Invoice must include the following:

- Detailed commodities description - this must match the description on the purchase order
- Harmonized Tariff Number (HTS#) – if the HTS on the purchase order does not match, please contact the Product Manager immediately
- Factory Name and Address FOR EACH ITEM
- Master carton quantity, cost, and piece count
- Item number
- Each line must have the measure and quantity of goods
- Value of goods in US dollars

The commercial invoice must show pieces as well as cartons, please see the example below. In the future, our customs house broker may request a universal commercial invoice and packing slip, at that time we will request you use the format given.



Section 5 – Wholesale

Commercial Invoice Page 1 of 1

Shipper: Vendor Name: Amscan Vendor Address: 47 Fitch Ave City, Pst+Poc, State, Country	Bill To: Anagram 47 Fitch Ave Glaston, NY 10005	Ship To: Anagram 47 Fitch Ave Glaston, NY 10005
---	---	---

Part of Entry: NQWAKK INCO TERM: FOB YANTUN Customer: 3	China Inv #: AG012300 Date: 15/03/12 BL of Lading: 60103111
--	--

Item No.	Description	MO	HTS Code (Tariff Code)	Country of Origin	UOM	Material No. / Qty	Unit Price (USD)	Total Cost (USD)	Vol (CBM)
243292	MA PLASTIC DOWRED	CANCOS83HON	7117.00.1000	CHINA	PC	60 CTNS	USD 24.00	USD 1,440.00	2.24
243293	MA PLASTIC DOWRED	CANCOS83HON	7117.00.1000	CHINA	PC	50 CTNS	USD 26.60	USD 1,330.00	2.24
243294	MA PLASTIC DOWRED	CANCOS83HON	7117.00.1000	CHINA	PC	10 CTNS	USD 98.60	USD 986.00	2.24
243295	MA PLASTIC DOWRED	CANCOS83HON	7117.00.1000	CHINA	PC	10 CTNS	USD 36.40	USD 364.00	2.24
243296	MA PLASTIC DOWRED	CANCOS83HON	7117.00.1000	CHINA	PC	10 CTNS	USD 36.40	USD 364.00	2.24
243297	MA PLASTIC DOWRED	CANCOS83HON	7117.00.1000	CHINA	PC	40 CTNS	USD 34.40	USD 1,376.00	2.24
Total Amount:							USD 1,376.00	USD 1,376.00	2.24

Packing List

PCHI requires a packing list as provided in the sample below:

Packing List

Page 1 of 1

Shipper:
 JCS Hong Kong Ltd.
 Room 1108 11/F Mirror Tower
 61 Mody Road
 Tsim Sha Tsui East
 Hong Kong

Bill To:
 Factory Card & Party Outlet
 2727 Diehl Road
 Naperville, IL 60563

Ship To:
 Amscan c/o Salson
 888 Doremus Ave
 Newark, NJ 08619
 973-986-0200

Country of Origin: China

Date: 20090416
PL#: PL-0411-09
CI#: 411086910633151
BOL#: 6910633151

Container #: HMMU9000125

Seal#: 1238522

Item #	Description	MO #	UOM	Cartons	Units	Weight (kgs)	Cube (cbm)
243292	MASTER CAULDRON ASST 3 FC	CNCALCOS83HON	6	52	312	124.80	5.33
243255	HAND MEAT MARKET FC	CNYUJOYSHE	3	6	18	9.99	0.11
243090	MASTER RUSTED CAULDRON 1 FC	CNRUIDASHE	3	56	168	128.23	5.28
243254	BRAIN MEAT MARKET FC	CNYUJOYSHE	3	6	18	12.76	0.25
243256	HRT MEAT MARKET FC	CNYUJOYSHE	6	6	36	13.07	0.27
243199	REALISTIC FOAM SKULL FC	CNSINCOM158SHE	12	7	84	16.23	1.30
243241	SLIMLINE TOMBSTONE 22IN FC	CNHDKPLA56XIA	18	16	288	233.54	2.33
243242	SLIMLINE SKLL CRSSBN TOMB FC	CNHDKPLA56XIA	9	10	90	8.23	0.86
243244	RIP TMBSTN/SKLTN BAT FC	CNHDKPLA56XIA	9	18	162	12.53	1.54
243298	BRONZE REAPER TOMBSTONE FC	CNHDKPLA56XIA	10	10	100	8.97	0.92
243093	MASTER RUSTED CAULDRON 2 FC	CNRUIDASHE	8	34	272	215.56	4.65
243190	WHT ANGL OF DTH CHST AST FC	CNYUJOYSHE	6	12	72	11.54	1.15
243249	GRIM REAPER HNG 6FT FC	CNKOL6SHE	12	17	204	197.54	2.05
Totals				250	1824	990.99	26.024

The packing list is a critical item. The list is used by the shipper or forwarding agent to determine the total shipment weight, volume and overall cargo accuracy. Moreover, customs officials (US and foreign) may use the list to review the cargo. Inaccurate or missing information may result in reimbursement charges as defined in the Reimbursement and Waiver Policy.

Section 5 – Wholesale

Documentation Distribution

Vendor must email a full set of original documents to chbimport@partycity.com.

Also required is a full set of non-negotiable documents be emailed to our customs house broker as designated by PCHI Logistics Import Team.

Document Origination	Type of Document	To PCHI Designated Company		To Vendor		To Forwarder / Consolidator / Ocean Carrier	
		# of originals	# of copies	# of originals	# of copies	# of originals	# of copies
Forwarder / Consolidator / Ocean Carrier	Express BOL	1	1		1		
	Forwarder Cargo Receipt (FCR)		1	3			
	Container Manifest		1				
Vendor / Shipper Government Documents	Commercial Invoice	1	1			2	1
	Packing & Weight List	1	1			2	1
	Export Permit	1	1			2	1
	Manufacturer's Labor Certificate	1	1			2	1
	Merchandise Testing Report from accepted CPSC lab	1	1			2	1
	GCC, as applicable	1	1			2	1
	CIQ China Inspection and Quarantine	1	1			1	1
	Veterinarian Health Certificate	1	1			1	1
	Drop Ball Test	1	1			1	1
	Impact Resistant Certificate	1	1			1	1
	Lacey Act/APHIS Declaration	1	1			1	1
	Vendor Feather Certificate	1	1			1	1
	Detailed Footwear Invoice/Wearing Apparel Invoice/Textile	1	1			2	1
	FCC Grant of Certification	1	1			2	1
	Country of Origin Certificate (Form A)	1	1			2	1
	Single/Multiple Country Declaration (if Applicable)	1	1			2	1
No Wooden Pallet Statement	1	1			2	1	

All documents must be submitted to the designated PCHI company for payment.

All documents and document distribution must be received on time and accurately or reimbursement charges will apply as defined in the Reimbursement and Waiver Policy, Section 8.



Section 5 – Wholesale

Delivered Duty Paid (DDP)

For a DDP shipment, Vendors are responsible for delivery to the PCHI DC door, including all freight costs, duties, and customs clearance under the Vendor's own importer of record number.

PCHI requires all DDP shipment to be routed as "Pre-Paid PCHI location". All freight, duty, and drayage should be prepaid and any demurrage is the responsibility of the Vendor.

All DDP shipments delivered to PCHI require a delivery appointment. Vendors must have a delivery appointment prior to delivery, (see routing instructions for making appointments with the DC's). It is the vendor's responsibility to calculate and manage all free days on all DDP containers. The designated drayage agent is up to the discretion of the vendor.

Amscan Distribution Center

East Coast DC (ECD):

Amscan
47 Elizabeth Dr
Chester, NY 10918

Tel: 845-469-9116
Fax: 845-469-5140
Keith Knoell Ext 2703 or Margaret Ferris Ext 2701

Anagram International Distribution Center:

Midwest DC (Edina DC):

Anagram International
5300 West 76th Street
Edina, MN 55439

Tel: 952-949-5854
Fax: 952-835-3094
Mike Longberg: 952-949-5865 or Adrian Peers: 952-949-5647

Vendors are responsible for all containers, including the pick-up of empty containers whether a return delivery is made or not. Containers MUST be picked up within 24 hours of PCHI fax notification.

If for some reason you cannot comply with these requirements, contact the PCHI Logistics team immediately to avoid reimbursement charges.

Landed Duty Paid Deliveries (LDP)

For an LDP shipment, Vendors are responsible for delivery to the port of entry determined by the PCHI Logistics Import team, including all freight costs and customs clearance under the vendor's own importer of record number. PCHI take possession of the goods after they have cleared customs.

PCHI prefers DDP shipments to LDP shipments. If PCHI issues a LDP order, the vendor must:

- Notify the designated PCHI Import team at least five business days prior to container arrival at the port of entry.

Vendors must contact the designated PCHI Logistics Import team to determine the port of entry.

Vendors are responsible for any freight charges if PCHI port selection is not followed or failure to obtain approval of delivery port.



Section 5 – Wholesale

Failure to comply may result in chargebacks for demurrage, additional freight charges or other issues as defined in the Reimbursement and Waiver Policy, Section 8.

For Anagram International contact:

PCHI Logistics Team - Imports		
Mike Longberg	mlongberg@anagramintl.com	952-949-5865
Adrian Peers	apeers@anagramintl.com	952-949-5647

For ALL other contact:

PCHI Logistics Team - Imports		
Fran Clark	fclark@amscan.com	914-784-4135
Peggy O'Brien	mobrien@amscan.com	973-453-8788
Lea Hale	lhale@amscan.com	973-453-8719

FOB Vendor Payment

Check/Wire Transfer

For all import POs (FOB/DDP/LDP), the Product Manager determines vendor payment terms and forwards all required payment request forms to the following:

Anagram International fax to 952-949-5609 Attn: Accounts Payable
For ALL other fax to 914-345-8684/8685 Attn: Rose DeRosa

The following is a wire transfer example:

SAMPLE Wire Transfer Instructions

Please provide all requisite Beneficiary information

From: China Supply and Consolidations Ltd.

RE: Banking Information

Beneficiary Name	China Supply and Consolidations Ltd.
Beneficiary Address in Full	99/L, CommMutual Tower, 32, Worchester Road Wanchai, Hong Kong
Beneficiary Account Number	527-0-123456-3 (USD)
Beneficiary Bank Location	Hong Kong
Beneficiary Bank Name	Hong Kong Peoples Bank (Hong Kong) Ltd.
Beneficiary Bank Address in Full	99 Dos Roeuk Road Branch 99 Dos Roeuk Road Central Hong Kong
Beneficiary Bank ID (Swift Address)	HKAMHKHH



Section 5 – Wholesale / Retail Canada

Exports

Overview

PCHI has locations worldwide and for items destined to these locations, we seek to follow all international trade guidelines. Due to these regulations and documentation requirements, Amscan encourages vendors to read and follow instructions thoroughly. Please note, shipping guidelines are generalized and may vary with each vendor, destination, or PO. Contact the Amscan Logistics team with any questions. We appreciate your cooperation in complying with the standards established for Amscan's Import program.

Canadian Retail Locations – USA Orders

Even though orders will be submitted as individual store orders, all the Party City Canada store orders are to be combined into one shipment destined to the consolidator listed below. Each carton must be clearly labeled by store to avoid confusion. Combining the orders and shipping to the Party City Canada's DC will allow an easier entrance into Canada and lower the shipping cost for our partners. We have negotiated rates below with Ameri-Connect who is currently clearing the shipments. We strongly recommend pre-paid vendors to take advantage of these rates as well.

PARTY CITY CANADA
2775 BROADWAY
BUFFALO, NY 14227

There are different regulations when shipping into Canada; we have listed the requirements as follows when shipping directly to Party City Canada's distribution center in Toronto.

Standard commercial invoice, please see attached example, must include the following:

- Each line must have the measure and quantity of goods
- The proper Canadian HTS number
- Value of goods in Canadian dollars
- Detailed description of goods
- Country of origin

Standard packing list, please see attached example, must include the following:

- Each line must have the measure and weight of goods per line
- Detailed description of goods

If your product is made in a NAFTA participating country, the commercial invoice must state 'These goods are wholly made in the USA'. For any invoices more than **\$20.00** a NAFTA certificate must accompany the documentation. This certificate is valid for **12** months. Once all the documents are complete, you must give the domestic carrier a copy and email them to the broker for clearance and to Amscan Logistics at Import.

Broker:

Ameri-Connect Freight Services Inc
Olga Poltorykhina
Tel: 416-679-8239 ext 270
Fax: 416-679-8253
email: olga@ameri-connect.com

Collect orders must use Ameri-Connect Freight Services Inc.

Section 5 – Wholesale / Retail Canada

Distribution / Wholesale Locations

For vendors shipping from the US to a PO address in a foreign country, the following documentation will be required.

- Commercial Invoice
- Packing list
- Bill of Lading
- Certificate of Origin
- NAFTA Certificate for items made in the US shipped to Canada or Mexico

Commercial Invoice

The Commercial Invoice must include the following:

- Detailed commodities description
- Harmonized Tariff Number (HTS#)
- Factory Address FOR EACH ITEM
- Master carton quantity, cost, and piece count
- Item number

Packing List

The packing list is a critical item. The list is used by the shipper or forwarding agent to determine the total shipment weight, volume and overall cargo accuracy. Moreover, customs officials (US and foreign) may use the list to review the cargo. Inaccurate or missing information may result in reimbursement charges as defined in the Reimbursement and Waiver Policy

The packing list must include the following:

- Individual net, legal tare and gross weights
- Total weight of all packages
- Measurements for each package
- Package markings with the shipper and item #
- Total quantity of packages
- General description of goods
- SKU number, item number and quantity of each
- Item number

Bill of Lading

- Destination
- Carton Count
- Seal Number
- Other standard requirements

Section 5 – Wholesale / Retail Canada

Shipping

Containers must meet Cubic Meter (CBM) minimum requirements. All LCL shipments require written approval from the Amscan Logistics Import team. Vendors are financially responsible for under-utilized containers based on minimum CBM requirements as listed below.

Container	Cubic Meter
20 (TEU)	28 CBM
40 (FEU)	58 CBM
40H (FEU)	65 CBM
45 (FEU)	68 CBM
48 (FEU)	72 CBM

Delivery to CFS (Consolidated Freight Station or EDC)

Delivery of freight is the responsibility of the vendor. All freight must be cleared by (country of origin) Customs prior to ship date. For visibility purposes, whenever possible, bookings (for delivery to CFS) shall be made on-line.

Vendor Booking Procedures with CFS (unless otherwise noted by CFS instructions):

- i. Vendor must fax or email all details / PO information to CFS Origin office using CFS Shipping Order Form.
- ii. All bookings must be submitted to the CFS origin no later than 7 days prior to cargo ready date.
- iii. Approval is required from CFS. Shipping order can be released by CFS to vendor for cargo delivery within 24 hours upon receipt of completed booking.
- iv. Only one shipping order per delivery to CFS.
- v. Daily booking cutoff time is 15:00 (3:00 PM); if the booking is received after 15:00, it will be processed the next working day.
- vi. The Shipper Name shown on shipping order is the Shipper Name shown on FCR.
- vii. Once the shipping order is released, any amendment to the shipping order must be communicated to CFS origin office for validation.
- viii. If the Vendor declares "no wood packing material", the vendor must include this statement on the shipping order, or by submitting a "no wood packing material declaration" on their company letterhead to CFS origin.

CFS Cargo Receiving Procedure, unless otherwise noted by CFS instructions:

- i. CFS will advise the closing date on the shipping order.
- ii. Origin Warehouse will check the condition and quantity of the cartons. The following conditions are not allowed without consignee's consent:
 1. Wet cartons
 2. Damaged cartons
 3. Carton marking by paper label
- iii. Vendor must deliver cargo by Shipping Order, by item number, by manufacturer style number (if not, a sorting charge will be incurred).
- iv. Vendor needs to notify CFS of partial delivery. All partial shipments must be delivered within three days of first delivery date.
- v. For late cargo delivery, vendors must obtain approval from CFS. Notification methods may vary by CFS.

Vendors must strictly adhere to consolidation cut-off times and check with the specified consolidator/forwarder. If cargo does not make the designated vessel's departure and is outside of the PO ship window, the PCHI Logistics Team may provide a routing change from the Import team or cancel the PO. All additional freight costs and penalties will be at the vendor's expense. Penalties and reimbursements are defined in the Reimbursement and Waiver Policy.



Section 5 – Wholesale / Retail Canada

Failure to comply with marking requirements will result in a deduction of full expenses incurred by Amscan, or our third parties, to meet import requirements.

In addition to the labeling requirements outlined in Packaging and Packing Instructions, Section 3b (unless specifically waived by PO), every carton must be clearly marked with the following information

- Country of Origin
- PO#
- Model and SKU or Item Number
- Quantity

Cartons with shippable inner quantities must be marked 'Re-Pack' with a bright label. Additionally, each inner carton must have the following information (Customs Requirements):

- Country of Origin
- PO#
- Model and SKU or Item Number
- Quantity

Vendors must place booking at least ten business days prior to the required ship date with the Amscan designated Consolidator/Forwarder/Ocean carrier.

Note: Vendors must provide the following information to the designated freight forwarder at the time of booking; otherwise booking will not be released:

- Shipper's name
- Shipper's full address
- Consignee name
- Detailed commodities description (no generic description)
- Harmonized Tariff Number (HTS #) and category
- Destination
- Carton count, quantity in carton, weight, and measurement
- Country of origin
- Final packing list

Section 5 – Wholesale / Retail Canada

Documentation Distribution

Document Origination	Type of Document	To Amscan		To Vendor		To Forwarder / Consolidator / Ocean Carrier	
		# of originals	# of copies	# of originals	# of copies	# of originals	# of copies
Forwarder / Consolidator / Ocean Carrier	Express BOL	1	1		1		
	Forwarder Cargo Receipt (FCR)		1	3			
	Container Manifest		1				
Vendor / Shipper Government Documents	Commercial Invoice	1	1			2	1
	Packing & Weight List	1	1			2	1
	NAFTA Certificate (if applicable)	1	1			1	1
	Veterinarian Health Certificate (if applicable)	1	1			1	1
	Vendor Feather Certificate	1	1			2	1
	Detailed Footwear Invoice/Wearing Apparel Invoice/Textile	1	1			2	1
	FCC Grant of Certification	1	1			2	1
	Country of Origin Certificate (Form A)	1	1			2	1
	Single/Multiple Country Declaration (if Applicable)	1	1			2	1
	No Wooden Pallet Statement	1	1			2	1

All documents must be submitted to Amscan for payment.

All documents and document distribution must be received on time and accurately or reimbursement charges will apply as defined in the Reimbursement and Waiver Policy.

Product Regulatory Compliance

It is PCHI's policy that products meet all applicable standards and regulations for the markets in which the products are sold. For example, Toys sold in Europe would need a CE mark and evidence that the item is in compliance with the Toy Safety Directive and testing specified in EN 71 and other applicable standards. Items sold in Australia or other countries need to meet applicable standards for that country. Please contact your local PCHI representative regarding product testing requirements for International markets.

Other Documentation

In addition to general procedures and documents, some products are subject to special export restrictions, permits, licenses, standards, and/or procedures. Vendor needs to provide all applicable documents for export and import to the destination country listed on the PO to the forwarder at the time cargo receipt. Any delays will result in a chargeback fee or penalty as outlined in the Reimbursement and Waiver Policy, Section 8.



Section 5 – Wholesale / Retail Canada

Product Invoicing

Invoices are to be submitted to the address of the receiving locations Headquarters or as listed on the PO. Product must be invoiced one PO# per invoice. Invoice is to be submitted in Master cases with the master case cost:

Contact information:

Logistics - Exports		
Lisa Basso	lbasso@amscan.com	914-784-4079
Peggy O'Brien	mobrien@amscan.com	973-453-8788



Section 5 – Wholesale

DC Bypass

Overview

The DC Bypass process allows for product to move directly to the Party City and Party America stores in an efficient and time-saving manner to meet the set dates for the stores' peak selling season.

If a purchase is written for the DC By-Pass process, you will be notified with the purchase order direction to ship to our CFS (consolidated freight station / warehouse) at Origin.

Purchase Orders

PCHI will create a Bulk PO; delivery will be to the CFS designated on the PO, along with the ship date. Ship-by date should be 10 days prior to a CY (direct to warehouse) ship-by date because time is needed to receive freight, sort, label, pack and load containers at origin.

On the right hand top corner of Bypass PO, it states the contact person for Amscan Asia Supply Chain Team (ASCT) who should be notified for any changes in the deliveries.

PCHI Bypass Team			
Name	Title	Email	Tel#
Karen Knecht	Inventory Manager	kknecht@amscan.com	914-784-4120
Peggy O'Brien	Compliance Specialist	mobrien@amscan.com	973-453-8788
Cheryl Fleishman	Logistics Administrator	cfleishman@amscan.com	973-453-8691
Ed Wtulich	Sr. Logistics Analyst	ewtulich@amcan.com	973-453-8796
Lea Hale	Customs Coordinator	lhale@amscan.com	973-453-8719
Andrew Medrick	VP Supply Chain & Transportation	amedrick@amscan.com	973-453-8613
Winfred Wong	Sr. Analyst	wwong@amscan.asia	011-852-3655-9148

Import Documents

Commercial Invoice

The Commercial Invoice must include the following:

- Detailed commodities description
- Harmonized Tariff Number (HTS#)
- Factory Address FOR EACH ITEM
- MID# as noted on purchase order; if not on p.o., contact PCHI Bypass Team
- Master carton quantity, cost, and piece count
- One (1) Purchase Order per Invoice, attention Maryann Sabia, cc: Logistics
- Item number
- For products made of wood, APHIS information must be included:
 - Article/component of the plant
 - Plant scientific name
 - Country of Harvest
 - Quantity of plant material
 - Unit of Measure
 - % of Recycled material

Packing List

The packing list must include the following:

- Individual net, legal tare and gross weights
- Total weight of all packages
- Measurements for each package
- Package markings with the shipper and item #
- Total quantity of packages
- General description of goods
- PCHI PO number
- SKU number, item number and quantity of each
- Item number

Packing List is to be included with freight delivered to the CFS.

Carton markings

In addition to the DC carton labeling requirements outlined in Section 3B (Labels will be required unless specifically waived by one of the above contacts listed in this section). The following information must appear on each master carton. For the DC Bypass program you may print directly on the master carton:

1. PCHI Item No.
2. Description
3. Country of Origin
4. Case Pack Quantity

UPC/Bar Code Requirements

- UPC's are checked for scanability and for the correct readable digits printed below the bar (human readable). **Despite the scanability, bar code format has to be Interleaved 2 of 5, 14 digits or standard subset, 6 symbology. Any deviated bar codes format will result in reject and rework at CFS will be charged back to vendors.**
- Bar Codes are scanned for correctness. All bar codes must scan and verify against ANSI standards with a grade of "C" or better.
- It is the vendor's responsibility to ensure correct scanability on all bar coding.

Master Carton

- Carton should always be made of durable, double-walled, shippable corrugate.
- For Masters weighing up to 20 lbs, the minimum requirements are 200 lbs per square inch (14.1 kgs per square cm) bursting test or 32 lbs per inch (5.7 kg per cm width) edge crush test.
- For Masters weighing over 20 lbs, the minimum requirements are 200 lbs per square inch (14.1 kgs per square cm) bursting test or 48 lbs per inch (8.6 kg per cm width) edge crush test.
- You may not mix SKUs in a Master.
- If cartons are received damaged at the CFS the vendor will need to supply new cartons and will incur labor charges for repackaging.

Section 5 – Wholesale

Packaging

- Packaging is checked to make sure that inners per master, eaches per inner, and eaches per master are correct according to PCHI's specifications.
- Packaging is checked to make sure correct packaging is used for each product if required (example: bubble wrap, corrugated inserts, special packaging if required / necessary).
- No strapping is to be used on master cartons.
- No staples are to be used on master cartons.
- No sub masters are ever to be used.

No Styrofoam materials are to be used on packaging or inside the master carton.

Labeling Requirements

- Labeling is checked on the master, inner, and eaches.
- Each carton must be labeled with the corresponding PCHI item #, description, Country of Origin and case pack quantity.
- Labeling for inner pack and eaches must all have scannable bar code and UPC printed in black on a white label with human readable digits underneath the bar code.
- **For USA bypass orders, both inner/master labels should be white with black print.**
- **For Canada bypass orders, a 3cm round green sticker is required to affix near the UPC sticker outside the master. This would help with differentiation between USA/Canada orders at CFS.**
- **For Halloween City bypass orders, both inner/master labels should be yellow with black print.**
- Each piece of merchandise must be labeled with the UPC number, vendor item number, U.S. vendor name and contact address, country of origin, and other information required by law.

Traceability

Children's products will need permanent distinguishing marks on the product, to the extent practicable, to identify the manufacturer, location, date of production and other necessary information for all goods manufactured on or after 8/14/09.

Delivery to CFS (Consolidated Freight Station or EDC)

Delivery of freight is the responsibility of the vendor. All freight must be cleared by (country of origin) Customs prior to ship date. **For visibility purposes, whenever possible, bookings (for delivery to CFS) shall be made on-line.**

Vendor Booking Procedures with CFS (unless otherwise noted by CFS/ASCT instructions):

- **Vendors should wait for ASCT's official notifications prior to placing bookings with designated CFS. Multiple CFS may be used in heavy volume programs and bookings should be placed to designated CFS according to ASCT's instruction.**
- Vendor must fax or email all details / PO information to CFS Origin office using CFS Shipping Order Form.
- All bookings **and other custom in bound documents** must be submitted to the CFS origin no later than 7 days prior to cargo ready date.
- **Vendors should ONLY submit items for bookings that are QC passed. Putting too many items in one booking will result in hold up of shipping order release if any of the items in the form is without pass testing status.**

Section 5 – Wholesale

- All shipments should be delivered to CFS using chartered trucking with no mixed load with other customer's cargoes.
- Approval is required from CFS. Shipping order can be released by CFS to vendor for cargo delivery within 24 hours upon receipt of completed booking and pre-registration of custom approval Vendors should seek approval from CFS on delivery arrangement such that CFS can plan ahead for unloading and receiving.
- Only one shipping order per delivery to CFS.
- Daily booking cutoff time is 15:00 (3:00 PM); if the booking is received after 15:00, it will be processed the next working day.
- The Shipper Name shown on shipping order is the Shipper Name shown on FCR.
- Once the shipping order is released, any amendment to the shipping order must be communicated to CFS origin office for validation.
- If the Vendor declares "no wood packing material", the vendor must include this statement on the shipping order, or by submitting a "no wood packing material declaration" on their company letterhead to CFS origin.

CFS Cargo Receiving Procedure, unless otherwise noted by CFS/ASCT instructions:

- ASCT will notify vendors on the timeline for receiving window. For any deliveries later than the deadline, vendors should seek approval from ASCT. Extension will only be considered and granted on a case by case review subject to program operation timeline.
- Origin Warehouse will check carton marking / dimensions according to the Shipping Order.
- Origin Warehouse will check the condition and quantity of the cartons. The following conditions are not allowed without consignee's consent:
 - Wet cartons
 - Damaged cartons
 - Carton marking by paper label
- Vendor must deliver cargo by Shipping Order, by item number, by manufacturer style number (if not, a sorting charge will be incurred).
- Vendor has to deliver the item in full quantity as per order placed. Partial delivery is not allowed unless approval is granted. Vendor needs to contact ASCT to apply for approval.
- If vendor has any questions on our measurement, please contact the CFS gatehouse for carton re-measurement within one day noted on "Cargo dimension discrepancy sheet".
- Vendor is required to verify the master weight and make sure the declared weight is accurate to meet compliance for Safety of Life at Sea regulation (SOLAS).
- If there is no problem with receiving, tallymen will sign and record actual receiving information on the mate's receipt.
- For late cargo delivery, vendors must obtain approval from CFS. Notification methods may vary by CFS. For example, some accept fax; others may utilize an on-line notification system.

Forwarder's Cargo Receipt (FCR)

- The shipping documents will be provided by PCHI, unless otherwise noted (CFS may have capability to produce shipping documents).
- Draft FCR will be prepared within 48 hours of cargo receiving date after the cargo has been successfully transferred to the consignee title.
- Vendor has to return back the draft FCR confirmation to CFS Origin.
- The original; FCR will be ready to pick up at our counter office with 48 hours after receipt of draft FCR confirmation from vendor.
 - **Required document for FCR exchange:**
 - Original Mate's Receipt
 - Check
 - Company Chop (Official Stamp)
 - Letter of Indemnity (if necessary)
 - If the vendor does not pick up the FCR in person, vendor must issue an authorization letter on the company letterhead, with authorized signature, to the nominated person who picks up the Original FCR.
 - General Certificate of Conformity
 - **FAMA for Licensed items**

Terms

1. The PCHI Logistics Import team will nominate a forwarder/consolidator/ocean carrier for all shipments. **ASCT will verify the port of loading with vendors and provide CFS location in order for vendors to proceed with bookings and deliveries, once receiving window is confirmed.**
2. Any shipper not delivering cargo to the designated consolidator/forwarder will be assigned a penalty and will be considered a DDP shipment. Please refer to the Reimbursement and Waiver Policy Section in this manual.
3. Merchandising/Product managers may not change/assign routing or import terms. All requests for changes to routing or terms for carriage must be sent to the PCHI Logistics Import Manager or Vice President of Transportation and Supply Chain in writing at least **fifteen (15)** business days prior to the vendor ship date.
4. Vendors must strictly adhere to consolidation cut-off times and check with the specified consolidator's office in advance if a "late gate" is needed. If cargo does not make the designated **receiving window, vendor must contact ASCT.** Late shipments will be handled on an individual bases. All additional freight costs and penalties will be at the vendor's expense. Penalties and reimbursements are defined in the Reimbursement and Waiver Policy.
5. All loads must ship from original country of origin. This includes the address of the CFS and relative Port. Goods must be shipped to the port/address in the original quoted price to PCHI. Port changes must be approved by PCHI and all fees associated are the Vendor's responsibility. Goods must be delivered within an agreed-upon timeframe if port change is accepted.
6. Case Pack: The vendor is responsible for matching the case pack identified in the PO. Any costs incurred (including freight and storage fees) as a result of incorrect case pack is the responsibility of the vendor.

Section 5 – Wholesale

7. Booking appointments with the CFS must be done ONLINE, based on availability. This is critical for visibility purposes. If vendor does not use the online booking tool, based on availability, additional costs will be incurred based on inconvenience and extra labor costs to extract data.
8. Damaged merchandise will need to be repacked or replaced, at the vendor's time, labor and expense.
9. Failure to comply with marking requirements will result in a deduction of full expense incurred by PCHI, or our third parties, to meet import requirements.
10. The CFS checks all merchandise for accuracy, including labeling, case weight and pack and dimensions. If there are discrepancies, vendor will be charged.

Failure to meet any of the above terms will result in chargebacks to the vendor.

VISA and/or Special Documents Required For Specific Items

In addition to general procedures and documents, some products are subject to special import restrictions, permits, licenses, standards, and/or procedures. To the best of our knowledge, below are the subject products PCHI may be importing:

Apparel or items containing textile

- Original VISA stamped document
- Manufacturer's Textile Declaration with authorized signature
- Denim Exclusion Statement for woven cotton garments on manufacturer's stationary with authorized signature
- Down detail statement-for items with down
- Certificate of Origin showing full name and address of the factory
- **General Certificate of Conformity**

Children's Products

- General Certificate of Conformity **or Children's Product Certificate (CPC)**

Art Materials

- General Certificate of Conformity

Wearing Apparel (See Apparel section above)

Composite Wood Products

- Chain of custody documentation which certifies use of compliant raw materials in accordance with the requirements of the California Air Resource Board (CARB) Airborne Toxics Control Measure (ATCM). This includes current Factory Certification at time of PO and production and product testing results, both showing compliance for formaldehyde emission.
- Lacey Act/APHIS information must be completed on the Plant and Plant Product Declaration Form

Footwear

- Interim footwear invoice
- Foxing or Foxing-like band
- Identity material of uppers
- Identify material of sole
- Open or closed shoe
- **General Certificate of Conformity**

Citronella Candles

- Lab report certifying that TSCA standard has been met and candle contains 3% or more of citronella content
- **General Certificate of Conformity**

Leather items, leather shoes, parts, and finished leather footwear

- Manufacturer's statement of "PCP" free declaration

Radio Items

- FCC Form 740
- **General Certificate of Conformity**

Eye Wear Products and Sunglasses

- Eyewear vendors need to provide the following documents along with the other shipping documents already provided, for example commercial invoice & packing list. Note that two documents (denoted by ***) are the same for both Sunglasses and Novelty Eyewear:

SUNGLASSES - Non-Exempt (Child & Adult) – 3 Documents

- Registration Number of Manufacturer & Device Listing Number of product(s) that are on the Bill of Lading (see RegList.pdf example within Appendix)
- Impact Resistant Drop Ball Test Certification (see IRC-1460.pdf within the Appendix) ***
- Copy of 3rd Party Test Report for **UV claim and** Impact test in accordance with 21 CFR 801.410 and description of sampling plan rationale (Typical test required by Amscan) ***
- **General Certificate of Conformity**

NOVELTY EYEWEAR - Exempt (Child or Adult; Child item is age graded under 14 yrs) – 3 Documents

- Impact Resistant Drop Ball Test Certification (see IRC-1460.pdf within the Appendix) ***
- Copy of 3rd Party Test Report for Impact test in accordance with 21 CFR 801.410 and description of sampling plan rationale (Typical test required by Amscan) ***
- Photocopy of a picture that clearly shows the *eyewear packaging with the following statement:*
"⚠ WARNING: These glasses are intended for novelty use only. Not designed to provide medical benefit or protect eyes from impact and UV rays. Please retain this information for future use."
- **General Certificate of Conformity**

Identify each photo with the item number that is on the bill of lading.

Please email to SP.AHI-FDA-IRC@amscan.com for each Non-Exempt item and shipment the following documents, as applicable:

- Registration Number of Manufacturer & Device Listing Number of product(s) that are on the Bill of Lading (see RegList.pdf within the Appendix)
- Impact Resistant Drop Ball Test Certification (see IRC-1460.pdf within the Appendix)

Items made of **natural or vegetable material; i.e., bamboo, straw, rattan, etc.**

- Certificate of Fumigation
- **Lacey Act Declaration**
- Items made of wheat or rice straw are **not acceptable**

Feather and Shell Products

- U.S. Fish and Wildlife Service Permit **or CITES if applicable**
- The following information must appear on the commercial invoice:
 - Common Name
 - Scientific Name (genus and species)
 - Number of piece
 - Value of the **product**
 - Country of Origin
 - Source (wild **or farm raised**)
- **Certificate of Fumigation**



Section 5 – Wholesale

Note: All natural feather products are required by USDA to be sterilized. PCHI conducts random testing for microbial content using USP 61/62 to confirm compliance with USDA requirements.

PEACOCK FEATHERS

Any items containing components of peacock feathers are not allowed to deliver without the presentation of the certificate to prove feather type and farm source of origin. Self-Declaration letter is to contain this information:

- Amscan PO number
- Item Description
- Quantity
- Delivery Date
- Material Genus and Species
- Scientific Name
- Country of Origin
- Manufacturer of the material
- Cites Report

Items containing Peafowl (peacock) feathers are not allowed to deliver without a CITES report. If items get caught by custom at destination without Cites report, items will be confiscated and trashed with all cost incurred in the process to chargeback to vendors.

• Lacey Act Declaration

As required by the Appliance Inspection Act of 1995, an importer must submit a declaration with a declaration to be required to report the information unless it displays a valid GMR control number. The valid GMR control number for this information collection and reporting. The declaration will complete this information collection. It is required to average 0.5 hours per report. The declaration is to be reviewed and approved, ensuring existing data sources, following and maintaining the data needed, and obtaining and reviewing the collection of information.

SECTION 1 - Shipment Information

Plant and Plant Product Declaration Form
Section 2: Lacey Act Amendment (16 U.S.C. 3372)

APHS
U.S. DEPARTMENT OF AGRICULTURE
ANIMAL AND PLANT HEALTH INSPECTION SERVICE

SECTION 1 - Shipment Information

1. INTAKE QUANTITY OF ARRIVAL (VENDOR QUANTITY)

2. PAPER NUMBER

3. CONTAINER NUMBER: Pre-Assembled

4. BILL OF LADING

5. N/A

6. EXPORTER NAME

7. EXPORTER ADDRESS

8. CONSIGNEE NAME

9. CONSIGNEE ADDRESS

10. DESCRIPTION OF MERCHANDISE

SECTION 2 - Compliance with Lacey Act Requirements (16 U.S.C. 3372(f))

For each article or lot, specify the following:

11. HARVEST YEAR	12. ENTERED VALUE	13. ARTICLE/COMPONENT OF ARTICLE	14. PLANT SCIENTIFIC NAME (GENUS)	15. COUNTRY OF HARVEST	16. QUANTITY OF PLANT MATERIAL	17. UNITS	18. FUR FURTHER RECYCLED

For each article or lot, specify the following:

19. HARVEST YEAR	20. ENTERED VALUE	21. ARTICLE/COMPONENT OF ARTICLE	22. PLANT SCIENTIFIC NAME (GENUS)	23. COUNTRY OF HARVEST	24. QUANTITY OF PLANT MATERIAL	25. UNITS	26. FUR FURTHER RECYCLED

Version 05-2014-08
PPO-F05V-020
AUGUST 2014

Page 1

Production control

As shipments were constantly seen with visible mold growth at the arrival of our DC warehouse, we require vendors to implement an effective mold prevention plan at the manufacturing facility to reduce the risk of mold development to the products. Moldy products cannot be sold since they are of poor quality and undermine our branding in retails. Most importantly, some types of mold can create health risks in certain individuals. As a result, moldy products will be destroyed at a cost chargeback to vendors. Loss chargebacks will include but are not limited to cost of goods sold, freight, handling and disposal cost, lab fees and loss of sale.

Vendors should always maintain the production facility dry and clean as moisture is the determining factor for mold growth. Any vendors producing items with the use of highly hygroscopic materials as below should stay more vigilant to the production process with best practices to start with material receiving / storage / manufacturing / packaging / finished goods storage and through shipment loading to containers.

- High Risk Items:
 - Wood / MDF
 - Flocked materials, fabric/paper/textile glue laminated products
 - Natural materials (natural rubber/natural down and feathers /real straw)
 - Denim materials treated with washing and bleaching
 - Products containing artificial fibers
 - Real leather or suede / imitation leather / suede in PU
- Production Check Points:
 - Incoming Material upon receiving
 - Unload materials in a clean and dry area
 - Visually check materials for cleanliness and moisture and use moisture meter to check moisture content
- Material storage:
 - Store materials in a clean, indoor room with the relative humidity below 60%
 - Do not store materials directly on the floor even temporarily
 - Materials must be stored on shelves or non-wooden pallets
- Production:
 - Production areas must be clean and dry with proper ventilation
 - To keep production area free from moisture contamination and separate the production area that include water/wet processing (such as painting, electroplating) from other production / packaging and storage areas
- Packaging:
 - Do not pack products when still warm from production
 - Glue and paint must be fully cured and dry prior to packaging, not just dry to the touch
 - Check moisture content of corrugated or cardboard material prior to use: avoid recycled corrugate, which is prone to absorb moisture more than new materials
 - Regardless of corrugate type, moisture content should be between 12% - 13%. Do not use if above 15%
 - Use effective package desiccants with proper dosage to absorb moisture
- Products/Finished goods storage:
 - Maintain a clean dry finished-goods warehouse
 - Control the relative humidity in the warehouse with an air conditioner or dehumidifier
 - Never store finished goods outside, even under a roof or cover

- Loading and Shipping:
 - Before loading the container, enclosed truck:
 - Visibly check to ensure the roof is clean and undamaged and there are no holes or cracks in walls, floors or roof. Reject the container if any damage is found
 - Use a moisture meter to check the moisture content of the wooden deck of the container, truck. Reject if the moisture content exceeds 25%
 - Check cargo for visible moisture before loading and pull product randomly to check for the moisture content with a moisture meter
 - Only load in dry conditions or under a roof that does not leak
 - Keep the loading area dry and clean
 - Avoid loading in the rain or fog



Section 5 – Wholesale

Rules for constructing the manufacturer code, "MID":

These instructions provide for the construction of an identifying code for a manufacturer or shipper from his name and address. The code can be up to 15 characters in length, with no inserted spaces. However, it may be thought of as five "pieces" as follows:

1 - COUNTRY (Piece 1: 2 characters)

Use the ISO code for the country, such as "PE" for Peru.

2 / 3 - MANUFACTURER NAME (Pieces 2 and 3: up to 3 characters each)

Use of the first three characters from each of the first two words of the name. There will be no third piece if the name is one word. Amalgamated Plastics Corp. would give "AMAPLA"; Bergstrom would give "BER".

If there are two or more initials together, treat them as a single word. For example, ABC Company, A.B.C. Company, or A B C Company would all yield "ABCCOM."

4 - ADDRESS LINE WITH STREET NAME and/or BOX NUMBER (Piece 4: up to 4 characters)

Find the largest number on this line and use up to the first four digits. For example, 11455 Main Street Suite 9999 would yield "1145". A suite number or a post office box should be used if it contains the largest number. However, use no number in the case of One Hundred Century Plaza.

There will be no fourth piece if there is no numeric on the address line. When numbers are separated by commas or hyphens, ignore all punctuation and use the number that remains. For example, either "12,34,56 Akasaka Road" or "12-34-56 Akasaka Road" would yield "1234". Note that the address line on the invoice may be after the line containing the city and zip code (or equivalent).

For example, German invoices frequently place the city and its numeric code before the street address. Be sure to identify the address line numeric and use it, not the city numeric.

5 - CITY (Piece 5: up to 3 characters)

Use the first three letters from the city name. Tokyo would be "TOK," St. Michel would be "STM."

Apply these general rules to construct a manufacturer code

1. Ignore all punctuation, such as commas, periods, ampersands.
2. Ignore all single character initials, such as the "S." in Thomas S. Delvaux Company.
3. Ignore the English words "a", "an", "and", "of", "the".
4. In the case where multiple company names and/or addresses appear on the invoice, use the name and address associated with the corporate headquarters as opposed to the division, office, etc.

Examples of some manufacturer names and addresses and their codes:

THE E.K. RODGERS COMPANIES One World Trade Center London, England SWLY 5HQ	GBEKRODLON
--	------------

THE GREENHOUSE 45 Royal Crescent Birmingham, Alabama, 35204	USGRE45BIR
---	------------

CARDUCCIO AND JONES 88 Canburra Avenue Sidney, Australia	AUCARJON88SID
--	---------------



Section 5 – Wholesale

Payment

Wire Transfer is the preferred method of payment for all import POs. The Product Development Manager determines vendor payment terms and forwards all required payment request forms via fax at 914-345-8684/8685 Attn: Rose DeRosa.

Product Invoicing

Invoices are to be submitted to the address below. Product must be invoiced one PO# per invoice. Invoice is to be submitted in Master Cases with the master case cost, and formatted to match the sample on following page.

Amscan Inc.
80 Grasslands Road
Elmsford, NY 10523

Attn: Accounts Payable / MaryAnn Sabia

Sample of Commercial Invoice:

Commercial Invoice
Page 1 of 1
Shipper: Vendor Name, Vendor Address 1, Vendor Address 2, City, Province, State, Country
Bill To: Amscan, 47 Elizabeth Drive, Chester, NY 10918
Ship To: Amscan, 47 Elizabeth Drive, Chester, NY 10918
Port of Entry: Newark, Incoterms: FOB Yantian, Container: HMMU8000125
Comm Inv #: 411088910833151, Date: 4/16/2008, Bill of Lading #: 6910633151
Table with columns: Item #, Description, MID #, HTS Code (Tariff Code), Country of Origin, UOM, Cartons, Case Cost (USD), Total Cost (USD)
Totals: 33, \$ 268.00

Must provide accurate MID # and HTS Code, the above is for example only and are not valid.



Section 5 – Wholesale

GENERAL CERTIFICATE OF CONFORMITY FOR CONSUMER PRODUCTS

CERTIFICATE DATE:

CERTIFIED BY:

MANUFACTURER NAME:

ADDRESS:

CITY:

STATE/PROVINCE:

COUNTRY:

PHONE#:

Importer: (Name, Address & Phone #)
Amscan Inc. 80 Grasslands Road Elmsford, NY USA 914-784-1910
Importer: (Record Keeping Contact)
VP - Product Safety 80 Grasslands Road Elmsford, NY USA 914-784-1910/minzalac@amscan.com

Item Number	Item Description	Vendor Number	Purchase Order #	Date of Manufacture (Month/Year)	Place of Manufacture (Factory Name, Address & Phone #)	Testing Date (Month /Year)	Place of Testing/ Third Party Testing Lab (Name, Address & Phone #)

In accordance with Section 14 of the Consumer Product Safety Act, 15 U.S.C. 2063(a), the manufacturer certifies that based upon a test or a reasonable test program, the product listed above complies with all applicable consumer product safety rules, bans, regulations or standards under the Consumer Product Safety Improvement Act (CPSIA) of 2008 or any other Act enforceable by the United States Consumer Product Safety Commission, as indicated in Table 1 below (check all that apply):

Check All That Apply

Table 1: Consumer Product Safety Rules (Children's & Other Applicable Products)

- | | | |
|--------------------------|--|-----------------------|
| <input type="checkbox"/> | Lead in Surface Coating (Children's Product) | 16 CFR 1303 |
| <input type="checkbox"/> | Lead in Substrate (Children's Product) | CPSIA 101 |
| <input type="checkbox"/> | Lead in Children's Metal Jewelry | CPSIA 101(a)(2) |
| <input type="checkbox"/> | Choking Hazard Labeling (Children's Product) | 16 CFR 1500.19 |
| <input type="checkbox"/> | Pacifiers (Children's Product) | 16 CFR 1511 |
| <input type="checkbox"/> | Rattles (Children's Product) | 16 CFR 1510 |
| <input type="checkbox"/> | Children's Products with Liquids | 16 CFR 1500.14 |
| <input type="checkbox"/> | Toys (ASTM F963) | CPSIA 106 |
| <input type="checkbox"/> | Flammability of Solids (Children's Product) | 16 CFR 1500.44 |
| <input type="checkbox"/> | Flammability of Textiles (Adult & Child) | 16 CFR 1610 |
| <input type="checkbox"/> | Flammability of Plastic Film (Adult & Child) | 16 CFR 1611 |
| <input type="checkbox"/> | Phthalates in Toy & Childcare Items | CPSIA 108 |
| <input type="checkbox"/> | Art Materials (LHAMA) | 16 CFR 1500.14(b) (8) |
| <input type="checkbox"/> | Other(please specify) | <input type="text"/> |
| <input type="checkbox"/> | Other(please specify) | <input type="text"/> |

"NOTE: Manufacturer shall email this WORD document using the naming format: **Item#_Vendor#_Certificate Date with MMDDYYYY** (For example, item 123456 from vendor number 999 made on November 12, 2008 would be 123456_999_11122008.doc) to the following distribution: sp.gcc@amscan.com



Section 5 – Wholesale

GENERAL CERTIFICATE OF CONFORMITY FOR CONSUMER PRODUCTS

CERTIFICATE DATE:	
CERTIFIED BY:	Anagram International
MANUFACTURER NAME:	
ADDRESS:	
CITY:	7700 Anagram Drive
STATE/PROVINCE:	Eden Prairie, MN 55344
COUNTRY:	USA
PHONE#:	952-949-5600

Item Number	Item Description	Date of Manufacture (Month/Year)	Place of Manufacture (Factory Name, Address & Phone #)	Testing Date (Month/Year)	Place of Testing/ Third Party Testing Lab (Name, Address & Phone #)

In accordance with Section 14 of the Consumer Product Safety Act, 15 U.S.C. 2063(a), the manufacturer certifies that based upon a test or a reasonable test program, the product listed above complies with all applicable consumer product safety rules, bans, regulations or standards under the Consumer Product Safety Improvement Act (CPSIA) of 2008 or any other Act enforceable by the United States Consumer Product Safety Commission, as indicated in Table 1 below (check all that apply):

Check All That Apply

Table 1: Consumer Product Safety Rules (Children’s & Other Applicable Products)

- Lead in Surface Coating 16 CFR 1303
- Lead in Substrate CPSIA 101
- Choking Hazard Labeling 16 CFR 1500.19
- Toys (ASTM F963) CPSIA 106
- Flammability of Solids 16 CFR 1500.44
- Phthalates in Toy & Childcare Items CPSIA 108
- Other(please specify)

--	--
- Other(please specify)

--	--

Section – 6a,c (Retail)

Transportation Routing Guide

Overview – Party City (includes Party City, Party America, and Halloween City)

The Transportation Routing Guide (TRG) provides information for merchandise and non-merchandise items destined to all Party City locations. Destinations include corporate and franchise stores, unless the PO specifies otherwise. Effective transportation management is a vital component in successfully managing our mutual supply chain. Our goal is to manage product flow, ensuring your merchandise reaches our customers while managing transportation transit times and operating at the lowest possible cost. The use of this Routing Guide (TRG) results in a streamlined method of moving products through our mutual supply chain contributing to our goal of providing excellent value and superior customer service.

Our goal is to ensure the most effective and efficient transportation modes are used for every shipment. This includes optimization of store inventory service level requirements, minimum transit days, and transportation/handling expenses. The LTL routing matrix may change from time to time; therefore, it is your responsibility to check on updates to the VSM and TRG. Failure to do so will result in chargebacks.

Contacts for Amscan/Party City Logistics: routing@partycity.com / routing@amscan.com

Jaime Perez
Tel: 973-453-8718
Fax: 973-983-6012
Email: jperez2@amscan.com

Jamie Wohlrabe
Tel: 973-453-8786
Fax: 973-983-4971
Email: jwohlrabe@amscan.com



Note: Failure to follow the instructions outlined in this TRG will serve as your agreement to absorb freight expenses as per the Reimbursement and Waiver Policy, Section 8.

SHIPPING LOCATIONS

The following is a list of Amscan / Party City shipping methods.

Direct Store Delivery (DSD)

Vendor sends all freight directly to the store assigned on the PO. Vendor must follow all guidelines listed in the DSD Shipping Instructions section of this TRG. This can be collect or prepaid based on the VPA terms.

Distribution Center (DC)

Vendor sends all freight directly to the Distribution Center assigned on the PO. Vendor must follow all guidelines listed in the DC Shipments section of this TRG. This can be collect or prepaid based on the VPA terms.



Section – 6a,c (Retail)

DSD SHIPPING INSTRUCTIONS (Party City and Party America locations)

Please note direct shipments to Halloween City in Livonia, MI refer to Wholesale Section 06b in routing guide.

The following shipping instructions are to be used for all direct to store shipments.

Please note for LTL size shipments going to stores 681, 821, 848, and 860, please contact Logistics to review the delivery hours and costs.

Vendor Paid Freight (Prepaid)

The cost of transportation/freight is included in the cost of goods. As the vendor is responsible for 100% of freight charges, vendor determines carrier selection.

Party City will not accept pre-paid and add to invoice, unless approved by the Amscan / Party City Logistics Team.

If a shipment does not meet vendor minimums as defined in Merchandise Information, Section 1, vendor must ship the order as Freight Collect using the appropriate carrier as per this TRG.

Vendor must have carton count listed on BOL and note store must sign for carton count upon delivery. For LTL deliveries selected carrier must call store for appointment or delivery is subject to being rejected.

Party City will chargeback for services required by vendors, or not requested by Party City, which are additional services and are billed to Party City. Carriers must contact the Amscan/Party City Logistics team to approve additional services requested by the store. *Please check our Accessorial Charges Section for the list of Charges that can be approved by Party City Logistics team.

Party City Paid Freight – (Collect) Domestic Shipment (48 Contiguous States)

Any freight shipping from Canada or other non-Domestic origins you must contact Logistics for routing. When shipping into Canada, please refer to the export section on page 101.

Freight Collect

This term must be noted on the BOL when shipping to a Franchise Store that is assuming responsibility for the freight costs. Please check the "Ship to Bill to" file (S2B2) when verifying if the franchise has a billing address different than the receiving address. If billing address is different than the shipping location then you must label the shipment 3rd party collect with the address of the franchise billing address, other locations will be labeled "Freight Collect". Vendors shipping LTL collect must adhere to the Routing Matrix found at the end of this section. This routing matrix may be updated from time to time, it is your responsibility to check the website for the most up to date version.



Section – 6a,c (Retail)

Third Party

This term must be noted on the BOL when shipping to a Corporate Store or during a Company Wide Roll-Out that is being paid for by Party City Corporate. The bill to address must be stated exactly as noted below.

**Party City Corporation
c/o Logistic Concepts, Inc.
PO Box 362
Cuyahoga Falls, OH 44222-0362**

Special Projects or Company Wide Rollouts

Please note for any Ad Fund, marketing shipments or rollouts, you must contact the Logistics Team for special shipping instructions.

Air/Express Shipments

Air/Express refers to shipments that must be expedited from a vendor to any Party City location. Each vendor must use Amscan / Party City's preferred carrier partner. For corporate shipments, you must be in receipt of a valid PO requesting express shipping; otherwise, the vendor must call the Party City Logistics Team to obtain approval. Franchisees will request service on POs or provide separately in writing; otherwise vendor must call the Franchisee to obtain prior approval. Refer to the Reimbursement Policy, Section 8, for information on failure to obtain prior approval.

10 cartons or less (1-10 cartons) or 400 lbs. or less (1-400 lbs.) If an individual carton weighs more than 40 LBS please call Logistics department before shipping.

Carrier	Customer Service Phone #	Web Site
UPS	1-800-742-5877	www.ups.com

You will need to contact Amscan / Party City's Logistics Team in advance to obtain appropriate account information to utilize UPS express services.

Greater than 10 cartons (11 cartons +) or greater than 400 lbs. (401 lbs. +)

Carrier	Customer Service Phone #	Web Site
GIO Express	888-291-9601	www.Gioexpress.com

All BOL requirements as outlined previously apply to Air Bills for Gio Express shipments.



Section – 6a,c (Retail)

Parcel Shipments

Applies to shipments weighing less than 500 lbs. (1-499 pounds) AND 40 cartons or less (1-40 cartons)

Shipments must be routed utilizing UPS Ground. Individual cartons cannot exceed 130 inches in girth with a maximum of 108 inches in length per package. If package exceeds 60 inches on a single side you must contact Amscan/ Party City Logistics team before shipping. The maximum weight of any single carton to a Party City location should not exceed 70 lbs.

Payment method selection for collect parcel shipments must be sent either "UPS Ground Collect" or "Third Party" Billing. **The determination of which payment method to use is located on each individual Vendor Participation Agreement (VPA). For Collect vendors, the UPS account numbers are located on the S2B2 file for that location which must be entered when shipping either method.** Do not add freight charges or handling charges to the invoice. UPS Ground barcode labels and shipping supplies can be obtained from UPS Ground by calling 800 PICK UPS (800-742-5877).

For UPS Ground Freight Collect Shipments (Do not use FedEx, DHL-Airborne, or USPS):

1. Use of shipping automation is required. This can be obtained by using www.ups.com homepage, UPS World Ship or any approved vendor manifest system. In the case none of these options are available, please contact Angelo Pira at 201-913-6154 or Tom Malmstone at 201-213-2206 and they can best accommodate the exceptions.
2. Vendors new to shipping to PCHI retail locations may contact routing for the store shipping file to be loaded into a UPS WorldShip Station for initial setup
3. UPS Ground will bill Party City directly for transportation charges. You must refer to the Ship-to-Bill-to (S2B2) to have the correct term used by store. If collect is listed for a store you must list collect as the billing method. If third party bill to is listed for a store you must list third party bill to as the billing method with the billing address for the store listed. It is possible for the shipping address to be identical to the billing address for certain stores.
4. Allow 24 hours for pickup if you are not a regular UPS Ground customer. Call 800-PICK-UPS (800-742-5877) to request a pickup or go online to www.ups.com. Just provide **your** UPS account number.

UPS contact regarding the Amscan / Party City account: **Angelo Pira**, Tel: 201-913-6154

Note: If you determine your Freight Collect shipment should be routed via parcel carrier, contact UPS to arrange for pickup. You can find information about UPS on their website, www.ups.com, or by calling UPS Customer Service at 800 PICK UPS (800-742-5877).

When shipping IT Equipment: For Freight Collect or 3rd party parcel shipping, all packages are automatically covered (insured) for up to \$100 per package. Before shipping packages via UPS Ground Collect or 3rd party valued over \$100, you must ask Amscan/Party City Logistics if they would like to cover the additional expense. All industry standard weekly pickup charges and liability for loss (claims) are the vendors' responsibility.

Note: Non-compliance will result in reimbursement to Amscan/Party City as described in the Reimbursement and Waiver Policy, section 8.



Section – 6a,c (Retail)

Parcel Documentation Requirements

The following elements are the only accepted form and must be included on each parcel carton label under the supplied reference fields:

(This information is found on the EDI 850 transmission sent by Party City to the vendor.)

1. Reference field 1 "PO number" – total 14 digits
Example 4 digits followed a "-" and then 9 digits: 0001-123456789
2. Reference field 2 "Carton Id / ASN number / UCC128" – total 20 digits
Example 20 digits: 00000092003139712890
3. Reference field 3 "Invoice number" – max of 20 digits (if available at time of shipment)

Less Than Truckload (LTL) Shipments

Applies to shipments weighing between 500 and 5,000 lbs. and up to 8 pallets. Anything larger please call the Amscan/ Party City Logistics Department.

For Freight Collect shipments vendor must use Amscan / Party City's **LTL Carrier Routing Matrix** section to determine which LTL carrier to utilize. From the **LTL Carrier Routing Matrix** use the State of Origin and State of Destination to select the carrier and ensure the designated carrier services the pickup and delivery locations as direct points. If carrier does not service your location as a direct point, contact Amscan / Party City's Logistics Team for assistance.

Note: All LTL shipments are **REQUIRED** to have delivery appointments.

Carrier	Customer Service Phone #	Web Site
New England Motor Freight	800-847-2728	www.nemf.com
JP EXPRESS	800-331-8065	www.myjexpress.com
UPS Freight	800-333-7400 option 2	www.upsfreight.com
YRC	800-610-6500	www.yrc.com

Delivery Appointment Scheduling

In order to better plan receiving functions at each store, all common carrier and vendor fleet shipments must be shipped with a Bill of Lading (BOL) clearly stating an appointment is required for delivery. We recommend the following verbiage:

"Appointment required for delivery. Call for appointment"

The store contact number is available in your Ship-to-Bill-to (S2B2) information. It is the responsibility of each vendor to ensure all information contained in the Party City vendor database is accurate by completing the Vendor Participation Agreement (VPA). If you have any questions regarding the contents of the S2B2 file, contact Amscan / Party City's Logistics Team.

Our stores generally have three (3) business days to schedule an appointment from the time a call for appointment is received. It is your responsibility (and your carrier's responsibility) to provide adequate time to schedule an appointment for seasonal shipments to arrive within the seasonal shipping window. A call for an appointment within the last two days of the seasonal receiving window could cause your shipment to be late.



Section – 6a,c (Retail)

LTL Documentation Requirements

The following elements must be included on each Bill of Lading (BOL), as applicable:

REQUIRED FOR MERCHANDISE BOL

1. The Purchase Order (PO) number for every PO on the shipment
2. Accurate carton and pallet count for the shipment
3. Accurate total shipment weight
4. Correct NMFC freight class for each item on the PO
5. Address and telephone number of shipping location
6. Address and telephone number of recipient location and **Store number**
7. Freight terms (prepaid or collect), **NEVER COD**
8. Third party billing address, if shipment is collect for Corporate store or Corporate paid roll-out, as listed:

**Party City Corporation
c/o Logistic Concepts, Inc.
PO Box 362
Cuyahoga Falls, OH 44222-0362**

9. Pick-up date/ Ship date (date shipment leaves vendor dock)
10. Carrier name
11. Carrier's PRO or tracking number
12. The statements,
 - o "Appointment required for delivery"
 - o "Call for appointment"
 - o "Sign for Carton Count"

Accessorial Charges

Party City will chargeback for services required by vendors, or not requested by Party City, which are additional services and are billed to Party City. Vendors must contact the Amscan/Party City Logistics team to approve additional services requested by the store. If approved it must be noted on the BOL or carrier must have store sign that service was completed.

Examples of additional services are:

- Driver and equipment are required to wait more than two hours past the scheduled appointment time to be loaded.
- Inside pick up or Delivery
- Lift gate
- Truck ordered not loaded

Section – 6a,c (Retail)

Shipping New Store Orders

Please contact Amscan/Party City Logistics Department before shipping begins.

- For Freight Collect- FOB Destination shipments, all new store POs from a specific shipping location must be consolidated to a maximum one shipment, the initial shipment, per new store location to minimize freight costs. Order must be shipped utilizing carrier information as outlined in this Transportation Routing Guide (TRG), Section 6 and Distribution Centers (DC) in the Imports Exports Bypass, Section 5.
- **All back orders on new store POs must be shipped as freight Prepaid, regardless of freight terms, or order minimums on file in VPA.**
- A packing slip must be inside, or attached to the lead carton (1 of X) for parcel deliveries or last carton (X of X). If inside, carton must be marked on the outside with the words "**Packing Slip Enclosed**".
- If shipping via common carrier or a vendor fleet, deliveries can have a packing slip inside, or attached to the lead carton (1 of X) or end carton (X of X). If inside, carton must be marked on the outside with the words "**Packing Slip Enclosed**".
- If shipping via common carrier or a vendor fleet, the Bill of Lading (BOL) must clearly state, "**Delivery Appointment Required – Call for Appointment**". Each PO has a contact name and phone number, which can be found on the cover sheet sent with the PO. You must use the contact person and phone number for all delivery appointments.
- Carrier or vendor must call for appointment no later than the day the shipment leaves the vendor's dock, with a minimum of three business days in advance of store receipt, allowing maximum time for store to fit into receiving calendar.
- Lift gate delivery services are required on all common carrier shipments or vendor fleet shipments of 3 pallets or greater.
- All shipments must meet requirements (labeling, packaging etc.) as outlined in Packaging and Packing Instructions, Section 3. Deviations require a written waiver **in advance** from Amscan/Party City's Logistics Department as described in Reimbursement and Waiver Policy, Section 8.
- Re-delivery, storage and other accessorial fees will be charged back to vendor if deviations from new store shipping/delivery requirements occur.
- Problems in transit, or deviations from original shipping information submitted to Amscan / Party City, must be immediately brought to the attention of Party City's New Store Merchandise Coordinator.
- For new store orders, the in store delivery date should be strictly adhered to. Any requested changes to this delivery date must be communicated to Facilities / Planning & Allocation Manager. Shipments that fail to meet delivery dates are subject to additional penalties based on costs incurred.

Section – 6a,c (Retail)

LTL Carrier Matrix		
Origin	Destination	Carrier
Alabama	ALL STATES	YRC
Arkansas	ALL STATES	YRC
Arizona	ALL STATES	YRC
California	CT, MA, ME, NH, NY, RI, VT	UPS Freight
California	OTHER STATES	YRC
Colorado	ALL STATES	YRC
Connecticut	CT, DE, DC, IL (Zips 600-629), MA, MD, ME, NH, NJ, NY, OH, PA, RI, VA, VT	New England Motor Freight
Connecticut	AL, GA, NC, SC, TN	JP Express
Connecticut	OTHER STATES	YRC
Delaware	CT, DE, DC, IL (Zips 600-629), MA, MD, ME, NH, NJ, NY, OH, PA, RI, VA, VT	New England Motor Freight
Delaware	AR, CA, LA, OK, OR, TX, WA	UPS Freight
Delaware	IN, MI, VW	UPS Freight
Delaware	OTHER STATES	YRC
District of Columbia	CT, DE, DC, IL (Zips 600-629), MA, MD, ME, NH, NJ, NY, OH, PA, RI, VA, VT	New England Motor Freight
District of Columbia	AR, CA, LA, OK, OR, TX, WA	UPS Freight
District of Columbia	OTHER STATES	YRC
Florida	ALL STATES	YRC
Georgia	ALL STATES	YRC
Idaho	ALL STATES	YRC
Illinois (Zips 600-629)	CT, DE, DC, IL (Zips 600-629), MA, MD, ME, NH, NJ, NY, OH, PA, RI, VA, VT	New England Motor Freight
Illinois	OTHER STATES	YRC
Indiana	IN, MI, VW	UPS Freight
Indiana	Other States	YRC
Iowa	ALL STATES	YRC
Kansas	ALL STATES	YRC
Kentucky	ALL STATES	YRC
Louisiana	ALL STATES	YRC
Maine	CT, DE, DC, IL (Zips 600-629), MA, MD, ME, NH, NJ, NY, OH, PA, RI, VA, VT	New England Motor Freight
Maine	OTHER STATES	YRC
Maryland	CT, DE, DC, IL (Zips 600-629), MA, MD, ME, NH, NJ, NY, OH, PA, RI, VA, VT	New England Motor Freight
Maryland	IN, MI, VW	UPS Freight
Maryland	AR, CA, LA, NM, OK, OR, TX, WA	UPS Freight
Maryland	OTHER STATES	YRC
Massachusetts	CT, DE, DC, IL (Zips 600-629), MA, MD, ME, NH, NJ, NY, OH, PA, RI, VA, VT	New England Motor Freight
Massachusetts	OTHER STATES	YRC
Michigan	DE, IN, MD, MI, NJ, OH, PA, VA, WV	UPS Freight
Michigan	Other States	YRC
Minnesota	ALL STATES	YRC
Mississippi	ALL STATES	YRC
Missouri	ALL STATES	YRC
Montana	ALL STATES	YRC
Nebraska	ALL STATES	YRC

Section – 6a,c (Retail)

Nevada	ALL STATES	YRC
New Hampshire	CT, DE, DC, IL (Zips 600-629), MA, MD, ME, NH, NJ, NY, OH, PA, RI, VA, VT	New England Motor Freight
New Hampshire	OTHER STATES	YRC
New Jersey	CT, DE, DC, IL (Zips 600-629), MA, MD, ME, NH, NJ, NY, OH, PA, RI, VA, VT	New England Motor Freight
New Jersey	AL, GA, NC, SC, TN	JP Express
New Jersey	IN, MI, VW	UPS Freight
New Jersey	OTHER STATES	YRC
New York	CT, DE, DC, IL (Zips 600-629), MA, MD, ME, NH, NJ, NY, OH, PA, RI, VA, VT	New England Motor Freight
New York	AR, LA, OK, OR, TX, WA	UPS Freight
New York	OTHER STATES (Covers pick ups in Upstate NY)	YRC
New Mexico	ALL STATES	YRC
North Carolina	ALL STATES	YRC
North Dakota	All States	YRC
Ohio	CT, DE, DC, IL (Zips 600-629), MA, MD, ME, NH, NJ, NY, OH, PA, RI, VA, VT	New England Motor Freight
Ohio	IN, MI, VW	UPS Freight
Ohio	OTHER STATES	YRC
Oklahoma	ALL STATES	YRC
Oregon	ALL STATES	YRC
Pennsylvania	CT, DE, DC, IL (Zips 600-629), MA, MD, ME, NH, NJ, NY, OH, PA, RI, VA, VT	New England Motor Freight
Pennsylvania	IN, MI, VW	UPS Freight
Pennsylvania	OTHER STATES	YRC
Rhode Island	CT, DE, DC, IL (Zips 600-629), MA, MD, ME, NH, NJ, NY, OH, PA, RI, VA, VT	New England Motor Freight
Rhode Island	AL, GA, NC, SC, TN	JP Express
Rhode Island	OTHER STATES	YRC
South Carolina	ALL STATES	YRC
South Dakota	ALL STATES	YRC
Tennessee	NJ, CT, RI, PA (Zips 175-176, 179-183, 185-187, 189-196)	JP Express
Tennessee	Other States	YRC
Texas	ALL STATES	YRC
Utah	ALL STATES	YRC
Vermont	CT, DE, DC, IL (Zips 600-629), MA, MD, ME, NH, NJ, NY, OH, PA, RI, VA, VT	New England Motor Freight
Vermont	OTHER STATES	YRC
Virginia	CT, DE, DC, IL (Zips 600-629), MA, MD, ME, NH, NJ, NY, OH, PA, RI, VA, VT	New England Motor Freight
Virginia	IN, MI, VW	UPS Freight
Virginia	OTHER STATES	YRC
Washington	ALL STATES	YRC
West Virginia	IN, MI, VW	UPS Freight
West Virginia	ALL STATES	YRC
Wisconsin	ALL STATES	YRC
Wyoming	ALL STATES	YRC

Please note for LTL size shipments going to stores 718, 821, 848, and 860, please contact Logistics to review the delivery hours and costs.



Section – 6b (Wholesale)

Transportation Routing Guide

DISTRIBUTION CENTER SHIPPING INSTRUCTIONS

The section of the Transportation Routing Guide (TRG) provides information for merchandise and non-merchandise items destined to all PCHI (Party City Holdings Inc) Distribution Centers. In order to plan receiving functions at each Distribution Center, all shipment pick-ups must be requested utilizing the "Pickup Request – Freight Collect Vendors" form. The form is available electronically and can be e-mailed. The form is also available in hard copy form for faxing. Sample of the form is included in the Appendix of this VSM.

Freight Collect

PCHI is responsible for 100% of the freight charges and for specifying which carrier to use. Our preferred carrier partner will bill the appropriate PCHI entity separately.

Freight Collect Vendors must utilize the "Pickup Request – Freight Collect Vendors" form to advise PCHI's Logistics Department that a freight collect shipment is ready for pick-up. PCHI's Logistics Department will send the "Pickup Request – Freight Collect Vendors" form back to the vendor with the carrier information. The selected carrier will call to make a pick up appointment with the vendor. The vendor will be responsible to e-mail or fax the packing list as soon as possible but no later than the actual pick up date to the following people.

For Chester Location

Joan Itzla
Tel: 914-784-4022
Fax: 914-345-8684
Email: jitzla@amscan.com

Jean Zaccagnino
Tel: 914-784-4026
Fax: 914-345-8684
Email: zaccagnino@amscan.com

Note: When emailing the packing list please include both contacts on the email.

For Naperville location

Dennis Delaney
Tel: 630-579-2067
Fax: 630-579-2467
Email: ddelaney@amscan.com

For Livonia MI location

Steve O'Toole
Tel: 734-591-1717 ext 5418
Fax: 734-591-3822
Email: sotoole@halloweencity.com

For Edina location

Mike Longberg
Tel: 952-949-5865
Fax: 952-835-3094
Email: mlongberg@anagramintl.com

Adrian Peers
Tel: 952-949-5647
Fax: 952-835-3094
Email: apeers@anagramintl.com

Note: When emailing the packing list please include both contacts on the email



Section – 6b (Wholesale)

“Pickup Request – Freight Collect Vendors” forms must be sent to:

E-mail pickup request to: routing@Partycity.com or routing@amscan.com

If you do not have email ability you may fax to: 973-983-4767. **Email is preferred.**

If you have any questions regarding the “Pickup Request – Freight Collect Vendors” form, contact Jaime Perez at Amscan/Party City at jperez2@amscan.com or 973-453-8718 or Jamie Wohlrabe at jwohrlabe@amscan.com or 973-453-8786. Business hours of the Amscan/Party City Logistics Department are Monday-Friday 8:00 AM – 5:30 PM Eastern Standard Time. Requests must be filed on a separate “Pickup Request – Freight Collect Vendors” form by DC locations.

Note: For all vendor locations for freight collect shipments assumed to operate in a SLC (shipper load and count) environment, vendor must provide seal & documentation.

Note: Vendors must accurately and comprehensively complete the forms, as PCHI will assign carriers, capacity, time and labor based on the shipment details (Date, cube, weight, pallets, etc.) provided on the form. In an event that any of the information is entered incorrectly and results in additional charges the vendor will receive a chargeback.

PCHI will provide pick-up information within three (3) business days of receiving a “Pickup/Delivery Request” form (carrier, pick up date, etc). It is your responsibility (and the carrier’s responsibility) to provide adequate time to schedule an appointment. Vendors are encouraged to contact PCHI Logistics as far in advance as possible to avoid delays and/or congestion on your dock.

Shipment Documentation Requirements

The following elements must be included on each Bill of Lading (BOL), as applicable:

REQUIRED FOR MERCHANDISE BOL:

1. The Purchase Order (PO) number for every PO on the shipment
2. Accurate carton and pallet count for the shipment
3. Accurate total shipment weight
4. Correct NMFC freight class for each item on the PO
5. Note if pallets are stackable
6. Address and telephone number of shipping location
7. Address and telephone number of actual recipient DC location as follows:

DC Locations

Amscan
47 Elizabeth Drive
Chester, NY 10918
845-469-9116 (Scheduling)

Party City.Com DC
2727 Diehl Road
Naperville, IL 60563
630-579-2067 (Scheduling)



Section – 6b (Wholesale)

Halloween City
35901 Veronica Street
Livonia, MI 48150
734-679-4947 (Scheduling)

Anagram International
5300 West 76th Street
Edina, MN 55439
952-949-5865

8. Freight terms (prepaid or collect), NEVER COD
9. If shipment is freight collect, mark bill to as follows:

For shipments designated to Anagram DC:

Bill to: Anagram International
7700 Anagram Drive
Eden Prairie, MN 55344

For ALL other shipments:

Bill To: Amscan c/o Party City Corporation
25 Green Pond Road, Suite 1
Rockaway, NJ 07866
Attn: Logistics Department

10. Pick-up date/ Ship date (date shipment leaves vendor dock)
11. Carrier Name
12. Carrier's PRO or tracking number
13. The delivery appointment date and time of advance appointment provided by PCHI
14. PCHI's Logistics Routing #

Accessorial Charges

Party City will chargeback for services required by vendors, or not requested by Party City, which are additional services and are billed to Party City. Vendors must contact the PCHI Logistics team to approve additional services requested by the store. If approved it must be noted on the BOL and carrier must have store sign that service was completed.

Examples of additional services are:

- Driver and equipment are required to wait more than two hours past the scheduled appointment time to be loaded.
- Inside pick up or Delivery
- Lift gate
- Truck ordered not loaded



Section – 6b (Wholesale)

Freight Prepaid

The cost of transportation/freight is included in the cost of goods. As the vendor is responsible for 100% of freight charges, vendor determines carrier selection.

PCHI will not accept pre-paid and add to invoice, unless approved by the PCHI Logistics Department.

If a shipment does not meet vendor minimums as defined in Section 1, Merchandise Information, vendor must ship the order as Freight Collect using the appropriate carrier as per this TRG.

Freight Prepaid vendors must fax or e-mail the packing list to the DC contacts below before the merchandise ships from the vendor’s dock. Failure to submit packing list of shipped product will result in a vendor chargeback. On Freight Prepaid orders it is the vendor or vendor’s carrier responsibility to secure an appointment with PCHI scheduling.

Freight Prepaid Shipments to Chester, NY – Must call for appointments:

Scheduling Desk: Margaret Ferris
Tel: 845-469-9116
Fax: 845-469-5140

If you have any questions regarding a prepaid shipment to the East Coast DC, contact Jaime Perez at Amscan / Party City at jperez2@amscan.com or 973-453-8718 or Jamie Wohlrabe at jwohlrabe@amscan.com or 973-453-8786.

Due to limited appointments per day carriers will need to call to schedule an appointment as soon as possible.

Business hours are Monday through Friday from 8:00 AM – 5:00 PM PST.

Receiving hours are Monday through Friday from 8:00 AM – 4:00 PM PST.

Prepaid Shipments to Naperville, IL - Must call for appointments:

Scheduling Desk: Dave Sanchez
Tel: 630-579-2067
Fax: 630-579-2467

If you have any questions regarding a prepaid shipment to the DC, contact Jaime Perez at Amscan/Party City at jperez2@amscan.com or 973-453-8718 or Jamie Wohlrabe at jwohlrabe@amscan.com or 973-453-8786.

Due to limited appointments per day, carriers will need to call to schedule an appointment as soon as possible.

Business hours are Monday through Friday from 8:00 AM – 5:00 PM CST.

Receiving hours are Monday through Friday from 6:00 AM – 2:30 PM CST.



Section – 6b (Wholesale)

Prepaid Shipments to Livonia, MI - Must call for appointments:

Scheduling Desk: Heather Lee
Tel: 734-679-4947
Fax: 734-591-3822

If you have any questions regarding a prepaid shipment to the DC, contact Jaime Perez at Amscan / Party City at routing@partycity.com or 973-453-8718 or Jamie Wohlrabe at routing@partycity.com or 973-453-8786.

Due to limited appointments per day, carriers will need to call to schedule an appointment as soon as possible.

Business hours are Monday through Friday from 8:00 AM – 4:30 PM CST.

Receiving hours are Monday through Friday from 8:00 AM – 3:30 PM CST.

Freight Prepaid Shipments to Edina, MN – Must call for appointments:

Scheduling Desk: Marilyn Wille
Tel: 952-949-5771
Fax: 952-835-3094

If you have any questions regarding a prepaid shipment to the Anagram International DC, Mike Longberg at mlongberg@anagramintl.com or 952-949-5865 or Adrian Peers at apeers@anagramintl.com or 952-949-5647.

Due to limited appointments per day, carriers will need to call to schedule an appointment as soon as possible.

Note: Vendors must accurately and comprehensively fax the packing list, as PCHI will base their receiving documents on the shipment details (Date, cube, weight, pallets, etc.) provided on the packing list. Failure to provide packing list before delivery will result in a vendor chargeback.

Section – 7a,c,d (Retail)

Accounts Payable

Overview – Party City (includes Party City, Party America, Party City Canada and Halloween City)

This section outlines important information for invoice requirements and processing policies. Accurate information will ensure timely processing of payments.

Direction for the processing of independent franchise orders, shipments and invoices will be given by the management of the individual franchise stores. You will be notified in advance if there are any changes to this process for any store or store group.

Invoice Requirements

Party City requires all merchandise vendors to submit invoices electronically (EDI 810) unless approved, in writing, for manual invoice submissions. (See EDI invoice requirements in EDI, Section 2. If you are not able to send invoices electronically, please contact Alissa Barrett, Accounts Payable Manager, to avoid non compliance charges and to determine actions required to become EDI compliant). All invoices submitted for processing must be submitted in the Vendor's currency and in turn will be remitted in the invoice currency.

ASN (Advanced Shipping Notice) Data

In addition, vendors are required to transmit ASN data electronically (EDI 856). (See EDI requirements in EDI, Section 2.) ASN data is a key component of the store receiving process and invoices can not be paid if ASN data is not provided. **Failure to provide ASN data within 24 hours of shipment will result in a charge of \$25 per shipment and \$5.00 per carton.**

Purchase Order and Invoice Data relationship and requirements

After a valid PO (EDI 850) is received from Party City, follow these procedures to ensure your invoices are paid on a timely basis:

1. Verify the accuracy of all PO details including unit cost*, payment terms, minimum order quantities, etc. Do not ship merchandise until all discrepancies on the PO have been corrected and the Merchandising Manager or the P&A Manager provides proof of correction to you in the form of a new PO.

***The unit cost on the invoice must not exceed the unit cost on the PO. Party City will not recognize any vendor price increase effective after the date of a PO. If a PO is accepted and the order is filled, the unit cost on the PO will be the basis of the liability for units received, not in excess of the order quantity.**

Telephone orders, and verbal commitments will not be considered binding.

2. Vendors are required to create one invoice per PO, per shipment, per shipping point and per "ship to" point. In other words, one invoice per PO delivery from one vendor location to one retail customer location. You may have multiple invoices per PO but you may not combine multiple POs on one invoice.

Section – 7a,c,d (Retail)

The following information must be included on the EDI invoice:

- The complete PO number, in its exact format with no changes (Do not combine PO numbers and/or locations on the same invoice).
- Your company or division name, as well as your Party City vendor number
- Your unique invoice number and invoice date (which must not be prior to the actual date the merchandise was shipped). There must be a unique invoice for each location and PO number.

Invoice numbers MUST NOT be reused. (See EDI invoice requirements in Section 2, EDI).

- Terms of the sale for the invoice (must be the same terms as provided on the PO)
- Ship to address and store number
- The item number along with a detailed item description
- The unit quantity shipped, unit cost and extended cost for each item (must be in eaches, not cases)
- The reference (Ref Si) that links the invoice to the shipment (same number provided on the ASN document) (see section 2a for more detail)
- Shippers PRO bill number, LCC number, or other tracking number to be used in obtaining Proof of Delivery
- Line item details, when totaled, must agree to header record of EDI invoice to the penny. If there is a discrepancy, we will pay the total of the line items.
- Off invoice allowances and charges must be provided as separate line items and must be coded using Party City approved codes only. (See page 6 for listing of valid codes. If a new code is needed to support a different charge or allowance type, please contact Alissa Barrett, Accounts Payable Manager)
- All invoices must be sent within 24 hours of shipment of goods.

Manual Invoices (If approved means of submission)

If manual invoices must be sent, all off-invoice allowances and charges not reflected on a Party City PO (included in the net cost) must be individually identified at summary level. Provide a net total dollar (in the correct vendor currency) of all allowances on the last page. Do not include allowances within the line item detail (as per example). This applies to manual invoices only. Each charge and allowance type must appear as a separate line on the invoice.

EXAMPLE				
Item	Description	Units	Cost	Extended Cost
12345	Party Goods	12	2.95	\$ 35.40
23456	Party Supplies	24	1.15	\$ 27.60
	Merchandise Total			\$ 63.00
	Allowances – specific			\$ (6.30)
	Other Charges – specific			\$ 9.95
	Total Invoice Amount			\$ 66.65

The invoice number MUST appear on each page of a hard copy multi-page invoice.

Section – 7a,c,d (Retail)

Provide a bill of lading with the invoice, or list the following on the invoice:

- Number of cases shipped
- Carrier Name
- Carrier's PRO/LCC number or BOL #
- Freight terms (FOB Destination, Collect, Vendor Truck, or Customer Pickup)

Send all manual invoices and billing related documents for Party City, Party City Canada, and Halloween City Corporate Stores to:

Party City Corporation
Attn: Merchandise Payables
Vendor ID# _____
25 Green Pond Rd Suite 1
Rockaway, NJ 07866

Invoice Processing Policies

Unless other agreements are made, deductions will be taken from invoices with quantity variances caused by shipment/picking errors, concealed shortages, carton shortages, concealed damages and overshipments. In addition, discrepancies in pricing will also create a deduction, if the invoiced cost is higher than the PO cost. These deductions will be identified on the remittance advice. The reference will be the original invoice number followed by "DM", identifying this as a debit memo.

The invoice due date will be based on receipt of goods and upon the most favorable of the invoice, PO or VPA terms. The system will age invoices based on the PO terms so it is important that the correct PO terms are on the purchase order.

Cash discounts and allowances will be calculated based on the gross amount of the invoiced merchandise and based upon the most favorable of the invoice, PO or VPA terms.

Party City reserves the right to deduct, from vendor payable balances, amounts for allowances, rebates, bill backs, returns, non-compliance charges, post audit claims and other receivables. Where balances cannot be collected timely, Party City reserves the right to request payment by check on balances due.

Remittance Advice

The corporate office in Rockaway will issue a single corporate check for Party City Corporate and Halloween City approved invoices. Party City Canada will remit a single corporate check for Canada locations.

The following information will be provided on the check and remittance advice:

- Vendor Number
- Vendor and/or Factor name
- Vendor/Factor remittance address
- Check number
- Check date
- Invoice number
- Invoice date
- PO number
- Cash Discount
- Net amount of invoice

Section – 7a,c,d (Retail)

Remittance Example:

PARTY CITY CORPORATION				No. 43125	
Date: 27-OCT-03		Vendor Name: ABC COMPANY		Vendor No. 123	
<u>Invoice Number</u>	<u>Invoice Date</u>	<u>Description</u>	<u>Gross Amt</u>	<u>Discount</u>	<u>Net Amount</u>
DC26336	30-SEP-03	538-99567	180.00	1.80	178.20
DC26338	30-SEP-03	528-88565	150.00	1.20	148.80
DC26338DM	30-SEP-03	518-33943	(120.00)		(120.00)
			<hr/>		
			210.00	3.00	207.00

Vendor Inquiries & Correspondence

Vendor inquiries regarding A/P transactions, balances and discrepancies must be directed to:

Party City Corporation
Attn: Merchandise Payables
Vendor ID# _____
25 Green Pond Rd Suite 1
Rockaway, NJ 07866

Vendors must state the situation in writing, attach supporting documentation to their written inquiry and send the package to Party City's A/P Department at the address referenced above. **All correspondence must include your vendor number.** Allow 2 to 4 weeks for a response.

Vendors may send inquiries via email to accountspayable@partycity.com

The Accounts Payable group phone number is (973) 453 – 8736.

The group fax number is (973) 983 – 4988.

Inquiries will be processed in the order received.

Changes to Vendor Information

Documentation on company letterhead must be emailed or faxed, and signed by a senior officer of your company. All changes must be received 14 days prior to the effective date. Changes would include, but not limited to:

- Change in remittance address
- Change in Company Name
- Change in ownership: If a change in ownership occurs and the new owner is not currently in our vendor file as an authorized vendor, the company will be considered a new vendor and will be required to complete all the documents required of a new vendor.
- Change in legal structure
- Bankruptcy filings
- Change in "Return to Vendor" address
- Change in Shipping locations

Section – 7a,c,d (Retail)

The letter communicating changes must contain the following information:

- Your company name and Party City vendor number
- Statement of the change being communicated
- Signature of a senior officer (if mailed or faxed). If communication is emailed, it needs to be emailed from the senior officer.

The mailing address for changes is:

Party City Corporation
Attn: Merchandise Payables
Vendor ID# _____
25 Green Pond Rd Suite 1
Rockaway, NJ 07866

Post Audit Policy

Party City may conduct Post Audits of all merchandise transactions. Party City reserves the right to file claims within 48 months of the event. Party City's auditors will submit all claims in writing and allow vendor 30 days to review and respond to the claims before any deduction is taken for those transactions that are more than 12 months old. Claims for transactions less than 12 months old will be deducted as discovered.

Overages

Party City, as a matter of policy, does not condone the shipment of overages. Overages will be processed. The vendor may be charged for the cost of processing the overage, a deduction for the cost of the goods, plus an administration fee as listed in the Reimbursement and Waiver Policy, Section 8.

Party City does not acknowledge any changes, which causes an overage if they are not communicated via a new PO. No handwritten notes, verbal, phone or faxed agreements will be accepted.

Party City reserves the right to return product at vendor's expense in addition to any expenses incurred for inbound freight, and/or administrative charges if terms are Freight Collect-FOB Destination.

Statement of Account

All vendors are required to send a complete statement of account of all open items, including all open invoices and credits to the Merchandise Payables department on a monthly basis. If the statement of account shows a Zero balance, still send this statement reflecting this for our records. **A separate statement is required for Party City Canada stores.**

The preferred method of receiving the statement is as follows:

1. Email an Excel or text electronic file of statement to statements@partycity.com
(You do not need to cc anyone)
2. Fax to: 973-983-4988 Attn: Merchandise Payables
3. Mail to: Party City Corporation
Attn: Merchandise Payables
25 Green Pond Rd Suite 1
Rockaway, NJ 07866

Section – 7a,c,d (Retail)

EDI Invoice codes to use in the SAC segment for charges and allowances:

CODE	ALLOWANCE DESCRIPTION
A170	ALLOWANCE ADJUSTMENTS
A260	ADVERTISING ALLOWANCE (I.E.. AD DISCOUNT)
A400	ALLOWANCE NON PERFORMANCE
B800	BOTTLE DEPOSIT RETURN
B950	DAMAGED MERCHANDISE
C000	NO RETURN CREDIT ALLOWANCE
C300	INV LOSS VENDOR DAMAGE CREDIT
C310	DISCOUNT
E730	NEW ITEM
E740	NEW STORE
E750	NEW STORE DISCOUNT
E760	NEW WAREHOUSE DISCOUNT
F800	PROMOTIONAL ALLOWANCE
F810	OTHER DISCOUNTS/ALLOWANCES
F970	REBATE
G860	SHRINK ALLOWANCE (CLR)
H000	SPECIAL ALLOWANCE(MARKDOWN ALLOWANCE)
I530	VOLUME

CODE	CHARGE DESCRIPTION
A250	ADVANCES(PREPAYMENT)
B240	COD Charges
C090	SHELL DEPOSIT - BEVERAGE
C110	BOTTLE DEPOSIT - BEVERAGE
C420	DRAYAGE
C440	DRIVER ASSISTED UNLOADING
C640	ENERGY CHARGE
D240	FREIGHT
D270	FUEL SURCHARGE
D500	HANDLING(UNDER MINIMUM ORDER)
D820	INSIDE DELIVERY
D920	INSURANCE FEE(FREIGHT INSURANCE)
F730	(OVERNIGHT) PRIORITY SERVICE (I.E.. 2ND DAY AIR)
G160	REDELIVERY
G240	REFUND
G470	RESTOCKING CHARGE(OVER ORDER)
H090	SPECIAL CHARGE (VENDOR CHARGE)
H400	STOPCHARGE
H600	TANK RENTAL
H625	CALIFORNIA BEVERAGE TAX
H700	CHICAGO WATER TAX
H701	ARKANSAS SALES TAX
H702	WEST VIRGINIA SALES TAX
H730	TAX
H750	LOUISIANA TAX
I500	VENDOR FREIGHT



Section – 7b (Wholesale)

Accounts Payable

Overview

This section outlines the general guidelines for PCHI (Party City Holdings Inc) Wholesale consisting of Amscan, Anagram International, and Grasslands Road unless stated otherwise. The guidelines included in this section are for invoice requirements and processing policies. Accurate information will ensure timely processing of payments.

Invoice Requirements

PCHI requires all merchandise vendors to submit paper invoices.

After a valid Purchase Order (PO) is received from PCHI, follow these procedures to ensure your invoices are paid on a timely basis:

Verify the accuracy of all PO details including unit cost, payment terms, minimum order quantities, etc. Do not ship merchandise until all discrepancies on the PO have been corrected and the Inventory Manager provides proof of correction to you in the form of an email notification or a new PO.

Telephone orders, and verbal commitments will not be considered binding.

Domestic Vendors

Domestic Vendors are required to create one invoice per PO, per shipment, per shipping point and per "ship to" point. Invoices are not to be sent prior to shipping.

The following information must be included on the invoice:

- The complete PO number, in its exact format with no changes (Do not combine PO numbers and/or locations on the same invoice).
- Company or division name
- Unique invoice number and invoice date (which must not be prior to the actual date the merchandise was shipped). There must be a unique invoice for each location and PO number.

The invoice number MUST appear on each page of a hard copy multi-page invoice. Invoice numbers MUST NOT be reused.

- The terms of the sale for the invoice must be clearly indicated
- Remit-to address
- Ship to address
- PCHI item number along with a detailed item description
- The Master Carton (MC) quantity shipped, MC unit cost and extended cost for each item
- Gross cost summation

Domestic Vendors are required to provide a bill of lading with the invoice, or list the following on the invoice:

- Number of cases shipped
- Carrier Name
- Carrier's PRO/LCC number or BOL #or other tracking number to be used in obtaining proof of delivery
- Freight terms (FOB Destination, Collect, Vendor Truck, or Customer Pickup)



Section – 7b (Wholesale)

Send all manual invoices and billing related documents to the appropriate wholesale entity:

Amscan Inc.
Attn. Accounts Payable Department
80 Grasslands Road
Elmsford, NY 10523

Anagram International
Attn: Accounts Payable Department
7700 Anagram Drive
Eden Prairie, MN 55344

Foreign/Bypass Vendors

- Foreign Vendors can combine PO numbers on one invoice but they must group the PO numbers together with the items. For example, list the first PO number followed by the item numbers, then the 2nd PO number followed by those item numbers, etc. Documents are to be sent at the time of shipment.
- Vendors shipping bypass must create a separate invoice for bypass shipments and US warehouse shipments. These two types of shipments cannot be combined on one invoice, they must be separate.

EXAMPLE ONLY

ITEM NO.	ITEM DESCRIPTION	QTY	MASTER CARTON	TOTAL QUANTITY	M/C PRICE	TOTAL
<u>P.O. NO.: 110011</u>						
303311	DOTS PRISMATIC HATS	(8 PCS/6PKG/108 PKG)	15	1620 PKG	\$50.00	\$750.00
404411	GARDEN FLOWERS INVITATION	(8 PCS/12PKG/216 PKG)	7	1512 PKG	\$70.54	\$493.78
<u>P.O. NO.: 110027</u>						
555444	BALLOONS PINT PAIL	(1 PCS/12PKG/288 PKG)	25	7200 PKG	\$38.00	\$950.00
777888	FLORAL QUART PAIL	(1 PCS/12PKG/288 PKG)	25	7200 PKG	\$49.50	\$1,237.50
<u>P.O. NO.: 110038</u>						
234555	WEDDING HANGING DECORATION	(5 PCS/6PKG/72 PKG)	50	3600 PKG	\$44.25	\$2,212.50
678999	JUMBO GIFT BAG - BLUE	(1 PCS/12PKG/144 PKG)	50	7200 PKG	\$40.00	\$2,000.00

The following information must be included on the invoice:

- The complete PO number, in its exact format with no changes (Do not combine locations on the same invoice).
- Company or division name
- Unique invoice number and invoice date (which must not be prior to the actual date the merchandise was shipped). There must be a unique invoice for each location.

The invoice number MUST appear on each page of a hard copy multi-page invoice. Invoice numbers MUST NOT be reused.

- The terms of the sale for the invoice must be clearly indicated
- Remit-to address
- Ship to address



Section – 7b (Wholesale)

- PCHI item number along with a detailed item description
- The “Each” quantity shipped, “Each” unit cost and extended cost for each item
- The Master Carton (MC) quantity shipped, MC unit cost and extended cost for each item
- Gross cost summation

Foreign/Bypass Vendors must provide quantity shipped and cost information both ways – Eaches for Customs purposes and Master Carton for accounting purposes.

Foreign/Bypass vendors are required to provide a Bill of Lading with the invoice. The following information must be included on the Bill of Lading:

- Number of cases shipped
- Carrier Name
- Carrier’s BOL #

Foreign/Bypass vendors are required to provide a packing list to accompany the invoice and Bill of Lading. The following information must be included on the Packing List:

- PO number
- Container number
- Item number
- Item description
- Total “each” quantity shipped by item number
- Total Master Carton quantity shipped by item number
- Net weight of each Master Carton by item number
- Cubic measurement of Master Carton by item number

Foreign/Bypass vendors are required to fax a complete set of shipping documents – Invoice, Bill of Lading and Packing List – to the Import Traffic Manager at the time of shipment. The original set of shipping documents should also be sent to the appropriate wholesale entity address below -

Amscan Inc.
 Attn. Import Traffic Manager
 80 Grasslands Road
 Elmsford, NY 10523

Anagram International
 Attn: Import Traffic Manager
 7700 Anagram Drive
 Eden Prairie, MN 55344

Amscan Inc.
 Attn: Maryann Sabia
 Bypass Invoices
 80 Grasslands Road
 Elmsford, NY 10523
 msabia@amscan.com

Invoice Processing Policies

Deductions will be taken from invoices with quantity variances caused by carton shortages, merchandise cost differences, and/or non-compliance due to improperly labeled or unlabeled product, non-compliant cartons, and/or non-compliant pallets.



Section – 7b (Wholesale)

Domestic Vendors

Deductions will be identified on the remittance advice. The reference number will be the original invoice number followed by a CM. A copy of the exception report will be included with the remittance.

Cash discounts will be calculated based on the gross amount of the invoiced merchandise.

Foreign/Bypass Vendors

Deductions will be listed on a wire remittance sheet and faxed to the vendor when payment is made. All supporting documentation for deductions will be faxed to the vendor.

Remittance Advice

Domestic Vendors

PCHI will issue a single corporate check for multiple invoices. The following information will be provided on Amscan's check and remittance advice:

- PCHI Vendor Number
- Vendor name
- Vendor remittance address
- Check number
- Check date
- Reference number (Invoice number)
- Reference date (Invoice date)
- Gross Amount
- Discount Amount
- Net amount of invoice

Foreign/Bypass Vendors

Foreign Vendors are paid by electronic transfer. PCHI will transfer a single amount for multiple invoices paid by wire. The following information will be provided on a wire transfer sheet faxed to the vendor:

- Vendor Invoice
- Invoice amount

Any deductions will also be listed and all supporting documentation will be faxed to the vendor.

Vendor Inquiries & Correspondence

Vendor inquiries regarding A/P transactions, balances and discrepancies must be directed to the appropriate wholesale A/P Department at the address below:

Amscan Inc.
Attn: Accounts Payable Dept.
80 Grasslands Road
Elmsford NY 10523

Anagram International
Attn: Accounts Payable Dept.
7700 Anagram Drive
Eden Prairie, MN 55344

Section – 8

Reimbursement and Waiver Policy

Overview

This section lists our reimbursement policies and charges by category for non-compliance issues for both retail (Party City, Party America, Halloween City and Party City Canada) and wholesale organizations (Amscan, Anagram International and Grasslands Road). All prior waivers are null and void as of December 31, 2013, unless another expiration date has been given on the waiver. Please see below for the approved waiver policy. **No telephone conversations, verbal agreements or any other agreements made will be honored unless the waiver policy is followed.**

Reimbursement Charges

The following chart lists non-compliance issues, the related organization type and the corresponding expense reimbursement charge:

PLEASE NOTE – There is a \$25 administrative fee for each chargeback issued.

Expense Offset Reductions

CATEGORY: TRANSPORTATION	RULE #	NON-COMPLIANCE ISSUES	REIMBURSEMENT CHARGES
RETAIL/WHOLESALE	10-100	NO LTL DELIVERY APPOINTMENT (Only if delivery is accepted, and not rescheduled)	\$50 PER SHIPMENT AND REDELIVERY CHARGES IF APPLICABLE
RETAIL/WHOLESALE	10-101	INCORRECT CARRIER USED/ FAILURE TO ROUTE ACCORDING TO THE TRANSPORTATION ROUTING GUIDE	\$25 PER INVOICE + FULL FREIGHT
RETAIL/WHOLESALE	10-102	UNAUTHORIZED ACCESSORIAL CHARGES (Notification, lift gate, etc.)	\$25 + ADDITIONAL COST
RETAIL/WHOLESALE	10-103	UNAUTHORIZED AIR SHIPMENTS	\$25 + FREIGHT CHARGES

CATEGORY: PACKING/LABELING/VENDOR DIRECT TO STORE	RULE #	NON-COMPLIANCE ISSUES	REIMBURSEMENT CHARGES
RETAIL/WHOLESALE	10-200	GS1-128 LABEL NOT ON CARTON, INCORRECT LABEL FORMAT, INCORRECT LABEL PLACEMENT OR MORE THAN ONE GS1-128 LABEL ON CARTON	\$10 PER CARTON
RETAIL/WHOLESALE	10-201	NO PACKING SLIP WITH SHIPMENT OR IF THE PACKING SLIP ARRIVES AFTER THE SHIPMENT	\$25 PER SHIPMENT
RETAIL/WHOLESALE	10-202	MULTIPLE POs PER CARTON	\$25 + \$25 PER CARTON
RETAIL/WHOLESALE	10-203	INCORRECT OR MISSING PO NUMBER ON REQUIRED DOCUMENTATION	\$25 PER SHIPMENT
RETAIL	10-204	GS1-128 LABEL NOT SCANNABLE/POOR QUALITY	\$10 PER CARTON
TICKETING/UPC RETAIL/WHOLESALE	10-205	INCORRECT UPC ON PRODUCT OR PACKAGE	(RETAIL) \$100 PER UPC (WHOLESALE) \$25 PER OCCURRENCE + \$.50 PER RETAIL SELLING UNIT
RETAIL/WHOLESALE	10-206	NO UPC TICKET	\$25 PER OCCURANCE + \$.50 PER RETAIL SELLING UNIT

CATEGORY: PACKING/LABELING/VENDOR DIRECT TO STORE	RULE #	NON-COMPLIANCE ISSUES	REIMBURSEMENT CHARGES
RETAIL/WHOLESALE	10-207	UPC NOT SCANNABLE/POOR QUALITY	\$25 PER OCCURANCE + \$.50 PER RETAIL SELLING UNIT
RETAIL/WHOLESALE	10-208	ITEMS INCORRECTLY PRE-PRICED OR REQUESTED ITEMS THAT DO NOT ARRIVE PRE-PRICED	\$25 PER OCCURANCE + COST OF DIFFERENCE PER SELLING UNIT; COST OF PRICING UNPRICED ITEMS \$.25 EACH UNIT
RETAIL/WHOLESALE	10-209	MISSING JULIAN DATE, INCORRECT FORMAT, INCORRECT ITEM # OR UPC OR PLACEMENT	\$25 PER OCCURANCE + \$.50 PER RETAIL SELLING UNIT OR \$5.00 PER INNER/MASTER CARTON ERROR
RETAIL/WHOLESALE	10-210	GS1-128 LABEL NOT MATCHING CARTON LABEL ID SENT IN ON ASN	\$10 PER OCCURANCE

CATEGORY: LOGISTICS	RULE #	NON-COMPLIANCE ISSUES	REIMBURSEMENT CHARGES
RETAIL/WHOLESALE	10-300	INCORRECT OR MISSING PO NUMBER ON REQUIRED DOCUMENTATION	\$100 PER SHIPMENT
WHOLESALE	10-301	INCORRECT, MULTIPLE OR MISSING PO #s or VENDOR #s ON MASTER CARTON	\$100 PER SHIPMENT + \$5 PER CARTON
RETAIL/WHOLESALE	10-302	CARTON LABEL MISSING OR NOT SCANNABLE (POOR QUALITY)/GS1-128 LABEL MISSING OR NOT SCANNABLE (POOR QUALITY) OR INCORRECT UPC ON INNER/MASTER CARTON OR OTHER INCORRECT INFORMATION	\$10 PER CARTON
WHOLESALE	10-303	PALLETS NOT SHRINKWRAPPED	\$25 PER PALLET
WHOLESALE	10-304	LABEL PLACEMENT INCORRECT (INNER OR MASTER)/LABELS NOT FACING OUT ON SHRINK WRAPPED PALLETS	\$.50 PER CARTON
WHOLESALE	10-305	UNACCEPTABLE OVERHANG ON PALLET/PALLET EXCEEDS ALLOWED HEIGHT OR DIMENSIONS (TOPS)	\$20 PER PALLET
WHOLESALE	10-306	INCORRECT PALLET SIZE	\$50 PER PALLET
WHOLESALE	10-307	UNACCEPTABLE PALLET QUALITY	\$75 PER PALLET
WHOLESALE	10-308	INCORRECT CASE PACK DIMENSIONS (TOLERANCE +/-1 inch), PALLET QUANTITY OR PRODUCT NOT SHIPPED IN CARTONS NUMBER, CASE PACK, UPC OR OTHER PERTINENT INFORMATION SUBMITTED ON NEW ITEM SET UP FORM (TOPS)	\$10 PER CARTON
WHOLESALE	10-309	PACKAGING NOT TO STANDARD, SEAL/TAPE, STRENGTH OF CORRUGATED, ROUNDED TOPS AND BOTTOMS, LOOSE FLAPS/STRAPPING OF MASTER CARTON/STAPLES IN MASTER CARTON/EXCEEDS 40 LBS.	\$100 PER SHIPMENT + \$.50 PER CARTON PLUS ANY SPECIAL HANDLING OR RTV CHARGES
WHOLESALE	10-310	SUBMASTERS OR SUBINNERS USED/INCORRECT PACK SIZE OR MULTIPLE PACK SIZES ON ONE PO	\$100 PER SHIPMENT PLUS SPECIAL HANDLING OR RTV CHARGES
WHOLESALE	10-311	PACKING SLIP MISSING, UNUSABLE, DATA MISSING OR INCORRECT	\$100 PER SHIPMENT
WHOLESALE	10-312	ACCESSORIAL CHARGES FOR SPECIAL HANDLING OR REPACKAGING	\$75 PER HOUR PLUS FLAT REIMBURSEMENT CHARGES
WHOLESALE	10-313	RETURN TO VENDOR CHARGES	\$50 PER PALLET PLUS

CATEGORY: LOGISTICS	RULE #	NON-COMPLIANCE ISSUES	REIMBURSEMENT CHARGES
			TRANSPORTATION CHARGES
WHOLESALE	10-314	STORAGE OF PRODUCT AWAITING DISPOSITION FROM VENDOR	14 DAYS AFTER NOTIFICATION TO VENDOR - \$10 PER PALLET PER WEEK
WHOLESALE	10-315	DISPOSAL OF NON-SALABLE PRODUCT (NON-HAZARDOUS MATERIAL)	\$5 PER CARTON
WHOLESALE	10-316	RECEIPT OF SUBSTITUTE ITEM OR ITEMS NOT ON PO	ITEM WILL NOT BE PAID FOR + COST OF DISPOSAL. \$200 FINE IF A DECISION IS MADE TO KEEP THE ITEM AND SELL THROUGH STOCK
WHOLESALE	10-317	HAZARDOUS MATERIAL TESTING FEE	\$100 + INVOICE COST FROM PCHI APPROVED LAB
WHOLESALE	10-318	DISPOSAL OF NON-SALABLE PRODUCT (HAZARDOUS MATERIAL)	\$100 + INVOICE COST FROM DISPOSAL COMPANY AND ANY RELATED FEES
WHOLESALE	10-319	MISCELLANEOUS – LOGISTICS	RELATED COSTS AND ADMIN FEES
WHOLESALE	10-320	PRODUCT SAFETY LABELS	\$0.50/PIECE, MINIMUM CHARGE OF \$100
WHOLESALE	10-321	WEIGHTS & MEASURES – INCORRECT CLAIM ON PACKAGING	\$0.25/EA/PIECE, PLUS COST OF MATERIALS AND ANY FINES FROM 3 RD PARTY IN APPLICABLE

CATEGORY: MERCHANDISING	RULE #	NON-COMPLIANCE ISSUES	REIMBURSEMENT CHARGES
RETAIL	10-400	<p>RECEIPTS LATE – EVERYDAY, SEASONAL & NEW STORES.</p> <p>LATE ORDERS ARE ORDERS RECEIVED IN STORE AFTER THE CANCEL-IF-NOT-DELIVERED BY DATE ON YOUR PO SENT VIA EDI</p>	<p>LESS THAN 1 WEEK LATE = 5% OF THE VALUE OF THE LATE MERCHANDISE. 1 WEEK OR GREATER AND LESS THAN 3 WEEKS=15% OF THE VALUE OF LATE MERCHANDISE. 3 WEEKS OR GREATER=25% OF THE VALUE OF LATE MERCHANDISE.</p>
WHOLESALE	10-400(B)	LATE SHIPMENTS WITHOUT APPROVAL – EVERYDAY & SEASONAL (BASED ON THE PROMISE DATE PROVIDED AT ORDER CONFIRMATION-IF THE INVENTORY MANAGER SUBSEQUENTLY APPROVES ANOTHER DATE FOR BOOKING PURPOSES, VENDOR IS STILL LIABLE FOR CHAREGBACK IF VENDOR WAS NOT READY TO BOOK BY THE PROMISE DATE PROVIDED AT TIME OF ORDER CONFIRMATION)	<p>LESS THAN 1 WEEK LATE = 5% OF VALUE OF LATE MERCHANDISE. 1 WEEK OR GREATER AND LESS THAN 3 WEEKS=15% OF VALUE OF LATE MERCHANDISE. 3 WEEKS OR GREATER=25% OF VALUE OF LATE MERCHANDISE.</p>
RETAIL	10-401	SHIPMENTS EARLY – SEASONAL & NEW STORES	5% OF THE VALUE OF THE EARLY MERCHANDISE
WHOLESALE	10-401(B)	SHIP EARLY WITHOUT APPROVAL – EVERYDAY & SEASONAL	20% OF THE VALUE OF THE EARLY MERCHANDISE
RETAIL/WHOLESALE	10-402	INCORRECT PRODUCT COST, ITEM NUMBER, CASE PACK, UPC OR OTHER PERTINENT INFORMATION SUBMITTED ON NEW ITEM SET UP FORM	\$200 PER ITEM THAT IS SUBMITTED INCORRECTLY
RETAIL	10-403	UNAUTHORIZED SHIPPING OF SUBSTITUTE ITEM / ITEMS ASN'D OR INVOICED NOT ON PO (Retail Only- Wholesale does not accept substitutions)	ITEM WILL NOT BE PAID FOR PLUS COST OF DISPOSAL



CATEGORY: MERCHANDISING	RULE #	NON-COMPLIANCE ISSUES	REIMBURSEMENT CHARGES
RETAIL/WHOLESALE	10-405	ITEM FOUND TO BE a) NON-COMPLIANT BY LAB TESTING OR SCANNING, b) DEFECTIVE, OR c) NON-COMPLIANT WITH PRODUCT SPECIFICATION	ITEM WILL BE DESTROYED OR RETURNED TO VENDOR AND FULL CREDIT ON COST OF ITEM, LOST RETAIL PROFIT, TESTING & INSPECTION FEES AND ALL OTHER RELATED EXPENSES WILL BE TAKEN
RETAIL	10-409	INCORRECT DIMENSIONS PROVIDED ON PACKAGING/SAMPLE	\$0.25 PER UNIT
RETAIL/WHOLESALE	10-410	PRODUCT NOT RECEIVED AT ALL FOR A SEASON OR GREATER THAN 4 WEEKS LATE FOR EVERYDAY	COST + LOST PROFIT ON THE ITEM'S UNSHIPED QUANTITY
RETAIL/WHOLESALE	10-411	PRODUCT SHIPPED DIFFERENTLY THAN BUYER APPROVED SAMPLE	COST + LOST PROFIT ON THE ITEM'S UNSHIPED QUANTITY. \$200 FINE IF A DECISION IS MADE TO KEEP THE ITEM AND SELL THROUGH STOCK
RETAIL	10-412	INCORRECT IMAGE PROVIDED FOR WEB, PICTURE WALL & MARKETING VEHICLES	\$200 PER OCCURANCE PLUS COST OF REPRODUCING AND EXPEDITED DELIVERY TO STORES
RETAIL	10-413	PICTURE WALL IMAGE INCORRECTLY MARKED ON ITEM PACKAGE	\$5 PER UNIT PURCHASED (COSTUME BAG RELABELED)
RETAIL	10-414	COSTUME UPC LABELED INCORRECTLY	\$5 PER UNIT PURCHASED (COSTUME BAG RELABELED)
RETAIL	10-415	COSTUME COMPONENTS IN PACKAGE ARE DIFFERENT THAN LISTED ON PICTURE WALL.	PER UNIT PURCHASED (PICTURE \$5 WALL, LOOK BOOK & COSTUME BAG RELABELED)
RETAIL	10-416	COSTUME SIZE SHIPPED DIFFERENT THAN ITEM INFO PROVIDED BY VENDOR	\$100 PER STORE (RELABEL PICTURE WALL AND LOOK BOOK)
RETAIL/WHOLESALE	10-417	ITEM IS DEEMED DAMAGED, DEFECTIVE OR NON-SALABLE	COST + LOST PROFIT ON THE ITEM + Handling, Disposal or Return and Transportation Cost
RETAIL/WHOLESALE	10-418	LABOR CHARGE TO RETURN OVERSHIPMENTS OR DUPLICATE SHIPMENTS AT VENDOR REQUEST	10% OF THE COST OF RETURNED MERCHANDISE - MIN OF \$25
RETAIL	10-419	PO SHIPPED TO WRONG LOCATION	EVERYDAY: 50% OF COST OF TOTAL MIS-SHIPED ORDER / SEASONAL: 100% OF COST OF TOTAL MIS-SHIPED ORDER.
WHOLESALE	10-420	ITEM MISSING COMPONENT(S) PER APPROVED SAMPLE	COST OF MISSING COMPONENT(S) (IF NOT REPLACING), OR COST OF LABOR AND/OR SHIPPING FEES TO REPLACE COMPONENT(S) (IF REPLACING) + \$500 PER OCCURRENCE.
RETAIL	10-421	ITEM PULLED FROM SALES FLOOR DUE TO PRODUCT SAFETY REGULATIONS AND RETURNED TO SALES FLOOR	\$0.50 PER UNIT RE-LABELING + LOST PROFIT ON ITEM
WHOLESALE	10-422	FAILURE TO PROVIDE ACCURATE FACTORY NAME, FACTORY LOCATION, AND CONTACT NAME WITHIN 14 DAYS OF RECEIVING A PURCHASE ORDER	\$100 PER ITEM PLUS ALL EXPENSES RELATED TO LATE OR INSUFFICIENT FACTORY APPROVAL
RETAIL	10-423	INCORRECT OR MISSING DOCUMENTS INCLUDING PRODUCT TESTING OR OTHER COMPLIANCE DOCUMENTS	\$500 + COST OF ANY ADDITIONAL CLEARANCE/DUTY OR DISPOSAL COSTS

CATEGORY: OTHER	RULE #	VENDOR ALLOWANCE CHARGES	REIMBURSEMENT CHARGES
RETAIL	10-406	AD ALLOWANCE	ALLOWANCE NOT APPLIED TO INVOICE OR BEING APPLIED BY ACCOUNTS PAYABLE
RETAIL/WHOLESALE	10-407	REBATE/VOLUME REBATE	ALLOWANCE NOT APPLIED TO INVOICE OR BEING APPLIED BY ACCOUNTS PAYABLE
RETAIL/WHOLESALE	10-408	MARKDOWN/OTHER ALLOWANCE	ALLOWANCE NOT APPLIED TO INVOICE OR BEING APPLIED BY ACCOUNTS PAYABLE

CATEGORY: ACCOUNTS PAYABLE	RULE #	NON-COMPLIANCE ISSUES	REIMBURSEMENT CHARGES
RETAIL/WHOLESALE	10-500	INVOICE WITHOUT PO NUMBER INCLUDED OR INCORRECT PO NUMBER	\$25 PER INVOICE
RETAIL/WHOLESALE	10-501	INVOICING WITH TERMS OTHER THAN THOSE CONTAINED ON THE PO (OR VPA IF NO TERMS ARE LISTED ON PO) THIS INCLUDES FREIGHT TERMS.	\$25 PER INVOICE
RETAIL/WHOLESALE	10-502	ACCEPTING PO WITH INCORRECT COST	\$25 PER INVOICE
RETAIL/WHOLESALE	10-503	MANUAL INVOICE FOR NON-ASN VENDOR	\$5 PER INVOICE
RETAIL/WHOLESALE	10-504	INVOICE WITH ITEMS NOT ON FILE OR UNAUTHORIZED SHIPMENT OF ITEMS (VMI)	ITEM WILL NOT BE PAID FOR
RETAIL/WHOLESALE	10-505	INVOICES WITH LOAD DATE MORE THAN 7 DAYS AFTER INVOICE DATE. INVOICES SENT MORE THAN 5 DAYS AFTER ASN SENT.	\$5 PER INVOICE
RETAIL/WHOLESALE	10-506	INVOICES LOADED WITH INCORRECT INVOICE DATE OR MISSING CHARGES AND ALLOWANCES	\$5 PER INVOICE
RETAIL/WHOLESALE	10-507	INVOICES WITHOUT SITE # OR WITH INCORRECT SITE #	\$25 PER INVOICE
RETAIL	10-508	INVOICES WHERE HEADER AND DETAIL AMOUNT DOES NOT MATCH, DOCUMENT MUST BE CORRECTED AND RESENT WITHIN 24 HOURS	\$5 PER INVOICE FOR INCORRECT DATA AND \$25 PER INVOICE NOT RESENT IN 24 HOURS

CATEGORY: EDI	RULE #	NON-COMPLIANCE ISSUES	REIMBURSEMENT CHARGES
RETAIL	10-600	RECEIPT OF MANUAL/PAPER CORPORATE STORE INVOICE AFTER EDI CERTIFICATION	\$10 PER INVOICE
RETAIL	10-601	INABILITY TO ACCEPT PO TRANSMITTED VIA EDI REQUIRING MANUAL (FAX, EMAIL, ETC) PO TO BE SENT	\$5 PER PO
RETAIL	10-602	FAILURE TO PROVIDE ASN FOR A SHIPMENT WHEN AN EDI 850 PO WAS SENT.	\$25 PER CARTON
RETAIL	10-603	FAILURE TO SEND THE ASN WITHIN TIMEFRAME. ASN MUST ARRIVE VIA EDI PRIOR TO SHIPMENT ARRIVING AT STORE	\$10 PER CARTON
RETAIL	10-604	ALL EDI DOCUMENTS REJECTED DUE TO INCORRECT OR MISSING DATA OR DUPLICATE DOCUMENTS SENT	\$25 PER DOCUMENT

CATEGORY: EDI	RULE #	NON-COMPLIANCE ISSUES	REIMBURSEMENT CHARGES
RETAIL	10-605	ALL REJECTED DOCUMENTS NOT CORRECTED AND RE-TRANSMITTED WITHIN 24 HOURS	\$200 PER BATCH/CONTROL #
RETAIL	10-606	INVALID CHARGE OR ALLOWANCE CODE SENT ON INVOICE	\$25 PER INVOICE
RETAIL	10-607	FAILURE TO SEND REF SI FOR INVOICE AND/OR ASN; SENDING MISMATCHED REF SI DATA	\$5 PER INVOICE/\$5 PER ASN ID
RETAIL	10-608	FAILURE TO TRANSMIT 997 ACKNOWLEDGEMENTS BY END OF NEXT BUSINESS DAY AFTER RECEIPT OF TRANSMISSIONS	\$5 PER PO
RETAIL	10-609	ACCEPTANCE/SHIPMENT OF DUPLICATE PO EITHER SENT VIA EDI, FAX OR PDF	\$10 PER CARTON. MERCHANDISE SHIPPED IS FREE OR VENDOR PAYS RETURN SHIPPING COST
RETAIL	10-610	DEVIATIONS FROM EDI MAPPING GUIDELINES RESULTING IN EDI TRANSLATION FAILURE	\$200 PER BATCH CONTROL #

CATEGORY: IMPORTS	RULE #	NON-COMPLIANCE ISSUES	REIMBURSEMENT CHARGES
WHOLESALE	10-700	INCORRECT OR MISSING DOCUMENTS INCLUDING PRODUCT TEST REPORTS OR OTHER COMPLIANCE DOCUMENTS	\$500 PER ITEM + COST OF DEMMURAGE and ANY ADDITIONAL CLEARANCE/DUTY OR DISPOSAL COSTS
WHOLESALE	10-702	INCORRECT CARTON MARKINGS	\$50 + \$5 PER CARTON
WHOLESALE	10-703	INCORRECT DATA OR IMAGE PROVIDED FOR QUOTE TO DETERMINE HTS	\$500 + ADDITIONAL COSTS FOR DUTY, CLEARANCE, STORAGE, DEMURRAGE OR DISPOSAL
WHOLESALE	10-704	ISF LATE, MISSING OR INCORRECT INFORMATION	\$500 + ADDITIONAL COSTS ASSESSED BY US CUSTOMS

CATEGORY: CUSTOM INVITATION/PERS ONALIZATION	RULE #	NON-COMPLIANCE ISSUES	REIMBURSEMENT CHARGES
RETAIL	10-800	DELIVERY AFTER CONFIRMED IN STORE DATE	SUBJECT TO PENALTY UPON VIOLATION
RETAIL	10-801	MISPRINTED ORDERS	SUBJECT TO PENALTY UPON VIOLATION

CATEGORY: DC BYPASS	RULE #	NON-COMPLIANCE ISSUES	REIMBURSEMENT CHARGES
WHOLESALE	10-900	INCORRECT CARTON MARKINGS OR LABELS	\$5 PER CARTON
WHOLESALE	10-901	MISSING OR DAMAGED CARTON LABEL	\$1 PER CARTON + RE-LABEL FEE
WHOLESALE	10-902	INCORRECT INNER LABEL	\$2 PER INNER + RE-LABEL FEE
WHOLESALE	10-903	MISSING OR DAMAGED INNER LABEL	\$1 PER INNER + RE-LABEL FEE
WHOLESALE	10-904	DAMAGED OUTER CARTON; VENDOR SENDS CARTON REPLENISHMENT	\$1 PER CARTON FOR RE-PACK



CATEGORY: DC BYPASS	RULE #	NON-COMPLIANCE ISSUES	REIMBURSEMENT CHARGES
WHOLESALE	10-905	CASE PACK DIMENSIONS CHANGE AFTER VENDOR RECEIVES PURCHASE ORDER	1% DEDUCTION TAKEN OFF PURCHASE ORDER, PER ITEM
WHOLESALE	10-906	CASE PACK QTY CHANGES AFTER VENDOR RECEIVES PURCHASE ORDER	1% DEDUCTION TAKEN OFF PURCHASE ORDER, PER ITEM
WHOLESALE	10-907	STORAGE FEE FOR EARLY OR LATE SHIPMENTS (OUTSIDE OF SHIP WINDOW)	\$0.50 PER CBM PER DAY
WHOLESALE	10-908	ITEM MOVES TO DC FOR LATE DELIVERY (OUTSIDE OF SHIP WINDOW)	2% DEDUCTION TAKEN OFF PURCHASE ORDER, PER ITEM
WHOLESALE	10-909	ITEM MOVES TO DC FOR FAILED TESTING (INCLUDES RESTRICTED ITEMS)	2% DEDUCTION TAKEN OFF PURCHASE ORDER, PER ITEM, PLUS LOST SALES OF RESTRICTED ITEMS
WHOLESALE	10-910	ITEM MOVES TO DC FOR CIQ ISSUE	10% DEDUCTION TAKEN OFF PURCHASE ORDER, PER ITEM <i>VENDOR RECEIVES WRITTEN WARNING; ITEM PROHIBITED FROM BYPASS PROGRAM. THREE (3) WARNINGS MAY DEEM VENDOR DISQUALIFIED FROM SERVING AMSCAN COMPANIES.</i>
WHOLESALE	10-911	PARTS REPLACEMENT / REPACKING	\$1 PER CARTON + \$1 PER PART
WHOLESALE	10-912	PARTS REPLACEMENT / REPACKING – NEW CARTON AND LABELS REQUIRED	\$5 PER CARTON + \$1 PER LABEL
WHOLESALE	10-913	PARTS REPLACEMENT / REPACKING – NEW CARTON AND LABELS REQUIRED	\$5 PER CARTON + \$1 PER LABEL
WHOLESALE	10-914	VENDOR CHANGES FOB PORT 15 DAYS AFTER RECEIVING PURCHASE ORDER	1% DEDUCTION TAKEN OFF PURCHASE ORDER, PER ITEM
WHOLESALE	10-915	VENDOR CHANGES FOB PORT 16-30 DAYS AFTER RECEIVING PURCHASE ORDER	2% DEDUCTION TAKEN OFF PURCHASE ORDER, PER ITEM
WHOLESALE	10-916	VENDOR CHANGES FOB PORT 31 + DAYS AFTER RECEIVING PURCHASE ORDER	3% DEDUCTION TAKEN OFF PURCHASE ORDER, PER ITEM
WHOLESALE	10-917	VENDOR PROVIDES INCORRECT FACTORY INFORMATION	\$100 PER ITEM
WHOLESALE	10-918	VENDOR DOES NOT PROVIDE FACTORY INFORMATION WITHIN 30 DAYS OF RECEIVING PURCHASE ORDER	\$10 PER ITEM
WHOLESALE	10-919	MIXED SKU'S RECEIVED IN SAME CARTON	\$50 PER CARTON + \$1 PER ITEM
WHOLESALE	10-920	MISCELLANEOUS – DC BYPASS	RELATED COSTS AND ADMIN FEES

NOTE: PCHI will process chargebacks for additional handling expenses, including transportation expenses, as a result of failure to meet the requirements in this Vendor Standards Manual.

NOTE: Product with quality assurance or regulatory compliance issues shall have resolution within THIRTY (30) DAYS of incident notice. After 30 days, all applicable product may be disposed of in accordance with local, state, and federal regulations and chargeback initiated in accordance with PCHI terms and conditions for non-compliant merchandise.

NOTE: Repeat offenses for non-compliant issues may be subject to a fine of \$250 in addition to current charges.



Waiver Policy

A vendor requesting a waiver of PCHI policies as defined in this Vendor Standards Manual must contact Party City's Merchandising Manager (for Retail), Amscan's Vendor Relations Specialist or Anagram International's Vendor Relations Specialist (for Wholesale) or Party City Canada's Director of Merchandising (for Canadian Retail) in writing or email in advance. Regarding a waiver from Amscan's Transportation, Logistics, Imports, and DC Bypass, you must contact Andrew Medrick, Vice President of Supply Chain and Logistics. Vendor must indicate in detail the policy to be waived and the reason for requesting the waiver. Indicate a timeframe for the waiver, i.e. a date when the vendor expects to comply with Party City policy. Vendor must also provide a contact person for correspondence with Party City, Amscan Inc., Anagram International or Party City Canada.

The request will be reviewed by the PCHI Vendor Relations team. If the request is approved, the vendor will receive a waiver form. If the request is not approved, the vendor will be contacted to discuss the issue.

Reimbursement Policy

Our expense reimbursement policy is intended to recover the costs incurred by PCHI due to vendor non-compliance to the requirements in the Vendor Standards Manual. Expense offset charges will be applied only when PCHI can clearly document a non-compliance to the 2017 Vendor Standards Manual (VSM) requirements.

If a vendor rebate program is based on purchase volume, the gross purchases will not be reduced, or netted down, by any reimbursement charges.

All inquiries or disputes related to Vendor Compliance Reimbursements to PCHI must be submitted in writing, within 45 days of the date you are notified the deduction is taken. Disputes received after 45 days from the date you are notified will not be reviewed. Vendors are required to demonstrate a chargeback was taken inappropriately prior to review for repayment. Inquiries or disputes should be sent to the appropriate location to the following e-mail address:

Amscan Inc.

Vendor Relations
vendorrelations@amscan.com

Anagram International

Vendor Relations
vendorrelations@anagramintl.com

Party City Corporation

Merchandise Payables
accountspayable@partycity.com

Party City Canada

Accounts Payable
accountspayable@partycity.ca



Disputes must include the following; otherwise, disputes cannot be appropriately reviewed:

- Letter with explanation of dispute
- Copy of the chargeback document(s) or Quality Control Information Sheet
- Transportation documentation if applicable (i.e. BOL, POD, etc.)
- Other documentation supporting dispute



Section - 9

Terms and Conditions

The following Terms and Conditions are part of the **Vendor Standards Manual** ("VSM") and are fully incorporated herein. Please note that once executed by Vendor, the **VSM** including but not limited to these Terms and Conditions, shall apply and shall continue indefinitely until amended or terminated.

1. **Definitions:** As used herein, the following terms shall have the following meaning: (a) "Order" means a purchase order or an order effectuated through Electronic Data Interchange Transmission (EDI) or any other means, which orders shall be deemed to include, in either event, these Terms and Conditions and (b) "Merchandise" refers to the goods, products, packaging, promotional materials including advertising, supplies, parts, assemblies, specifications, services or other items constituting the subject matter of the Order which are to be furnished by the Vendor to Amscan Inc. (Amscan), Party City Corporation or their franchisees, affiliates or subsidiaries hereunder. References to "THE COMPANY" include Party City Holdings, Inc ("PCHI"), all wholesale and retail subsidiaries of PCHI, including but not limited to, Amscan Inc., Grasslands Road, Anagram International, Party City Corporation, Party America, Halloween City, Party City Canada and any franchisees affiliated with any of the foregoing.

2. **Warranties:** Vendor represents and warrants to THE COMPANY, in addition to all warranties expressed or implied by law, that the Merchandise and its use, importation, design, construction, assembly, production, shipment, sale, packaging, labeling, packing, advertising, instructions and warnings or lack thereof and other printed matter furnished or authorized by Vendor, shall (a) be free from defects in design, workmanship and/or materials, including, without limitation, such defects as could create a hazard to life or property; (b) be suitable for end use; (c) be manufactured, packed for shipment, marked with the country of origin or other information required by law or regulation and where required, be registered, tested and certified to conform with all applicable federal, state and local laws, and the laws of any United States Commonwealth or any country or territory where THE COMPANY does business, including the Commonwealth of Puerto Rico, and all orders and regulations promulgated thereunder; (d) (i) not infringe or encroach upon any party's personal, contractual or proprietary rights, including patent, designing trademark, tradename, servicemark, copyright, right of privacy or publicity or trade secret rights; collectively hereafter ("Proprietary Rights") or (ii) not have been or be the subject of any allegation by any party alleging violation of such party's Proprietary Rights; (e) not violate or breach any agreement that Vendor may have with a manufacturer or distributor; (f) conform to all specifications, guidelines, other descriptions and delivery dates set forth or incorporated in the Order and all articles accepted by THE COMPANY as merchandise samples; (g) possess all performance qualities and characteristics claimed in advertisements or representations made, issued or authorized by Vendor; (h) be in conformity with the Federal Food, Drug and Cosmetics Act, the Federal Trade Commission Act, the Consumer Product Safety Improvement Act or any other federal, state or local law, and the laws of any United States Commonwealth or any country or territory where THE COMPANY does business, including the Commonwealth of Puerto Rico, and all orders and regulations promulgated thereunder; (i) be properly stamped, tagged, labeled, or marked with such information as may be required by any applicable law, regulation or order or by THE COMPANY; (j) be well within any expiration date indicated on the packaging of the Merchandise; (k) have been stored under proper conditions to preserve the quality of the Merchandise; and (l) meet all applicable requirements of all applicable United States federal, state and local laws and regulations and of all applicable laws and regulations of jurisdictions outside the United States. Vendor also represents and warrants that (m) the weights, measures and sizes of all Merchandise shall be as represented and conform to all standards, regulations and requirements of any federal, state or local governmental authorities having jurisdiction, and any United States Commonwealth or any country or territory where THE COMPANY does business, including the Commonwealth of Puerto Rico; (n) the prices, terms and conditions of sale hereunder and any discount, rebate or allowance for advertising or otherwise granted by Vendor in connection herewith are not in violation of the Robinson-Patman Act and are in compliance with all applicable laws and regulations; (o) have raw materials, packaging, and all components of the finished product that are free of radiation or other contaminants which have adverse effects on human health or environment;



and (p) no forced labor or child labor shall be or was utilized in connection with the manufacture of the merchandise. Vendor's representations and warranties herein shall survive the delivery of Merchandise to THE COMPANY and any resale of Merchandise by THE COMPANY.

3. Product Compliance Tests: For those items provided directly to the retail entities of THE COMPANY, Vendor for PCHI retail entities, at its sole cost and expense, shall perform, or cause to be performed, all tests on the Merchandise required by the Customer Product Safety Commission and any other federal, state and local laws, or the laws of any United States Commonwealth or any country or territory where THE COMPANY does business, including the Commonwealth of Puerto Rico, and shall maintain for a period of not less than three (3) years certificates indicating that all applicable tests have been administered and passed. Such tests shall be conducted on an annual basis or sooner as may be required by any applicable law, rule or regulation, by Intertek Testing Services (ITS), Modern Testing Services (MTS), MSR Laboratories (MSR) or equivalent CPSC approved laboratories or OSHA National Approved Testing Laboratory for electrical safety, including but not limited to UL, ETL, CSA. Vendor shall make available and furnish at THE COMPANY's request, copies of such certificates and shall permit THE COMPANY, or any person or persons authorized by THE COMPANY, to inspect and make copies of all records maintained by Vendor in connection with such tests. In the event Vendor does not test its products **to applicable and/or mandatory federal, state or local standards**, THE COMPANY may test those products and either withhold payment as a result of such testing or chargeback the cost of such testing to the Vendor. For those items provided to Amscan, for purposes of wholesale distribution, Amscan shall, until further notice, perform, or cause to be performed, all tests on the Merchandise required by the Consumer Product Safety Commission and any other federal, state and local laws, or the laws of any United States Commonwealth or any country or territory where THE COMPANY does business, Amscan shall pay for production sample testing for the first sample run and all other production runs as requested. However, if the product fails testing, Vendor will need to pay for all fees associated with the failed testing report and each subsequent test on that item until it receives a passing result.

4. Registration and License Numbers: Vendor shall obtain and provide to THE COMPANY any and all registration numbers, license numbers, or the like, required by any federal, state, local, foreign, provincial or territorial governmental agency or authority having jurisdiction over the Merchandise type in question, the sale of such Merchandise, and/or any claims made regarding the Merchandise or any of its qualities. In the event vendor is working only with Amscan Inc., the registration numbers, license numbers and the like shall be sent to Amscan Inc., 80 Grasslands Road, Elmsford, New York 10523, Attention: Vendor Relations. In the event vendor is working only with Party City Corporation, registration numbers, license numbers and the like shall be sent to Party City Corporation, 25 Green Pond Road, Suite #1, Rockaway, NJ 07866, Attention: Vendor Relations. In the event vendor is working with both Amscan Inc. and Party City Corporation, registration numbers, license numbers and the like shall be sent to Amscan Inc., 80 Grasslands Road, Elmsford, New York 10523, Attention: Vendor Relations.

5. Material Safety Data Sheet: Vendor shall provide THE COMPANY a Material Safety Data Sheet ("MSDS") as required by THE COMPANY or pursuant to the Occupational Safety and Health Act (OSHA) and any other federal, state, or local law, regulation or order prior to the delivery of Merchandise particularly including, but not limited to, those products that the end-user could have dermal, oral, respiratory or other bodily exposure to. An MSDS, if required, shall also be included with the first delivery of any Merchandise to each of THE COMPANY's Stores. In the event vendor is working only with Amscan, the registration numbers, license numbers and the like shall be sent to Amscan Inc., 80 Grasslands Road, Elmsford, New York 10523, Attention: Vendor Relations. In the event vendor is working only with Party City Corporation, registration numbers, license numbers and the like shall be sent to Party City Corporation, 25 Green Pond Road, Suite #1, Rockaway, NJ 07866, Attention: Vendor Relations. In the event vendor is working with both Amscan and Party City Corporation, registration numbers, license numbers and the like shall be sent to Amscan Inc., 80 Grasslands Road, Elmsford, New York 10523, Attention: Vendor Relations.

6. Terms must be in Writing: No terms or conditions in any acceptance, acknowledgment, invoice or other document submitted by Vendor that are in conflict with, different from, or in addition to these Terms and

Conditions, nor any modification of the Order, shall be binding upon THE COMPANY unless agreed to in writing by a duly authorized representative of THE COMPANY.

7. **Purchase Order:** (a) An Order, when in the form of a written purchase order, shall constitute an offer on the part of THE COMPANY upon these Terms and Conditions and shall become a binding contract between THE COMPANY and Vendor upon Vendor's acceptance of the Order by:

- (1) signing one copy of the Order and returning it to THE COMPANY; or
- (2) returning a signed written confirmation of the Order to THE COMPANY; or
- (3) delivering to THE COMPANY, in accordance with the Terms and Conditions as set forth in the Order, all or any part of the Merchandise ordered; or
- (4) allowing ten (10) days to lapse from the time the Order is received by Vendor, neither accepting the Order in the manner indicated above nor giving THE COMPANY written notice of rejection of the Order.

(b) An Order, when in the form of an EDI transmission or email, shall constitute an offer on the part of THE COMPANY upon these Terms and Conditions and upon any terms and conditions indicated in the EDI transmission and shall become a binding contract between THE COMPANY and Vendor upon Vendor's acceptance of the Order by:

- (1) delivering to THE COMPANY, in accordance with the Terms and Conditions as set forth in the Order, all or any part of the Merchandise ordered; or
- (2) electronically acknowledging receipt of the Order coupled with failure to reject the Order within two (2) business days following its receipt; or
- (3) allowing ten (10) days to lapse from the time the Order is received by Vendor, neither accepting the Order in the manner indicated above nor giving THE COMPANY written notice of rejection of the Order.

8. **Prices:** The prices specified in the Order are not subject to any additional charges for packing or preparation for shipment due to increased costs of operation, or because of any taxes or excises levied on processors, manufactures, wholesalers or otherwise. The Order shall not, without written authorization from THE COMPANY, be fulfilled at higher prices than specified therein, or, if the Order is not priced, at prices higher than last charged or quoted to THE COMPANY for Merchandise described therein. Vendor agrees that any price reduction made to the Merchandise described in the Order prior to the delivery of such Merchandise to THE COMPANY shall be applicable to the Order. Whenever price is dependent upon cubic density, such density shall be specified by Vendor.

9. **Changes to an Order:** THE COMPANY may at any time make changes in written, electronic or facsimile form to any Order, including changes in the drawings or specifications, methods of shipment, warranties, packing, or time or place of delivery at any time prior to 30 days before the start ship date for the Merchandise. If such changes result in an increase or decrease in cost of, or time required for the performance of the Order, an equitable and reasonable adjustment shall be made in the price, delivery schedule or both. If such changes result in an increase in cost or time which is unacceptable to THE COMPANY, then THE COMPANY in its sole discretion may cancel its request for such changes.

10. **Timeliness:** Time is hereby made of the essence on the Order. If delivery of Merchandise is not completed by the date set by THE COMPANY, THE COMPANY reserves the right, without liability and in addition to its other rights and remedies at law, in equity or under the terms of the Order, to purchase elsewhere and hold Vendor liable for any additional loss, cost, damage or expense incurred thereby. Vendor shall pay any loss, cost, damage or expense resulting from the untimely receipt of the Merchandise ordered. Vendor shall notify THE COMPANY immediately if it is unable to ship timely. THE COMPANY shall have the right to refuse any goods with untimely delivery and to cancel the balance of the Order for any part of the goods due after untimely delivery of any installments. By accepting the untimely delivery of any installment, THE COMPANY shall not be bound to accept

future shipments nor be deprived of its right to return Merchandise already accepted nor to claim damages for untimely delivery.

11. **Order Postponement:** THE COMPANY shall have the right to require Vendor to postpone shipment of Merchandise or suspend work covered by the Order and Vendor shall take all reasonable steps or minimize costs during such suspension. Equitable adjustment shall be made to the price, delivery schedule or other provisions affected by the suspension, provided that the claim for equitable adjustment is made within thirty (30) days after THE COMPANY directs the continuation of the work.

12. **Order Termination:** (a) THE COMPANY may terminate an Order, or any part thereof, by notice to Vendor under any of the following circumstances:

- (1) If Vendor fails to comply with any provisions of the Order.
- (2) If Vendor becomes insolvent or makes a general assignment for the benefit of creditors or files or has filed against it a petition of bankruptcy or for reorganization, or pursues any other remedy under any other law relating to the relief for debtors or in the event a receiver is appointed for Vendor's property or business.
- (3) If THE COMPANY receives notice of an allegation of Proprietary Rights infringement or believes that there may be an infringement of Proprietary Rights regarding the Merchandise that is the subject matter of the Order.

In the event of such termination, in addition to all other rights and remedies THE COMPANY may have at law, in equity or under these Terms and Conditions, THE COMPANY may purchase or manufacture similar Merchandise and/or require Vendor to transfer title and deliver to THE COMPANY any and all property produced or procured by Vendor under the Order and Vendor shall be liable to THE COMPANY for any excess cost to THE COMPANY.

- (b) In addition to THE COMPANY's right to terminate an Order for cause pursuant to Paragraph 12 (a) above, THE COMPANY may terminate an Order in whole or in part at any time upon notice to Vendor. On receipt by Vendor of such notice, Vendor shall, to the extent specified therein, stop work thereunder and the placement of work with subcontractors, terminate work under subcontracts outstanding thereunder, and take any necessary action to protect property in Vendor's possession in which THE COMPANY has or may acquire an interest. In such event, THE COMPANY shall pay to Vendor the amounts due for supplies delivered and accepted or services completed in accordance herewith prior to the effective date of termination.
- (c) Any termination by THE COMPANY whether for cause or otherwise, shall be without prejudice to any claims for damages or other rights of THE COMPANY against Vendor.
- (d) Vendor shall continue performance of the Order to the extent not terminated.

13. **Right to Refuse Merchandise:** THE COMPANY shall have the right to refuse Merchandise not in accordance with specifications or industry standard or breaches of any warranties contained herein, or which is different in quality or quantity from that ordered, or which is shipped otherwise than as specified under the Order or which is believed by THE COMPANY to violate a third party's Proprietary Rights or is alleged to violate a third party's Proprietary Rights. THE COMPANY may, at its sole discretion, either return rejected Merchandise or hold same at Vendor's risk and expense and may, in either event, charge the Vendor with the cost of transportation, shipping, unpacking, examining, repacking, storing, reshipping, disposal and other like expenses as well as the right to chargeback Vendor for the loss of sales and punitive damages for any harm to THE COMPANY's business reputation as a result of any breach of warranty hereunder. For purposes hereof, the "right to chargeback" shall mean vendors payment to THE COMPANY of an amount equal to the sum of lost wholesale and retail profit, as applicable, defined as follows: i) for wholesale- 100 percent of the lost profit based on the difference between the total carrying cost and the average wholesale selling price at the time of loss for the affected inventory and ii) for

retail- 100 percent of the lost profit based on the difference between the average wholesale selling price and the average retail selling price at the time of loss for the affected inventory. For "Everyday" items, the lost retail profit shall be based on 80 percent of the inventory. If Vendor fails to accept Merchandise returned by THE COMPANY, then THE COMPANY shall have the right to dispose of such Merchandise by any means. If within thirty-six (36) days after a request by THE COMPANY for direction regarding disposition of rejected Merchandise, Vendor does not respond to THE COMPANY, THE COMPANY shall have the right to dispose of the Merchandise by any means. Acceptance of any prior shipments contrary to the Order shall not be considered a waiver of THE COMPANY's right to return any or all of the Merchandise and receive full credit therefore. Authorization for substitution of style, color, size, quantity or a combination thereof, is permitted only upon the written, signed and dated consent of THE COMPANY. Any claims for defective Merchandise, shortages, returns, damages, or other claim of set off asserted as a result of Vendor's failure to comply with these Terms and Conditions made by THE COMPANY will be charged back to Vendor and the amount thereof deducted from payments to be made to Vendor or, alternatively, will be promptly refunded to THE COMPANY.

14. **Right to Return Merchandise:** THE COMPANY may at any time after delivery of the Merchandise (and whether or not the same has been accepted by THE COMPANY) return all or part of the Merchandise if any part is found to be in a damaged or defective condition or has breached any warranties herein or if believed by THE COMPANY to violate a third party's Proprietary Rights, or if alleged to violate a third party's Proprietary Rights. Vendor shall refund to THE COMPANY in full the price paid by THE COMPANY for such returned Merchandise as well as the right to chargeback. Any Merchandise so returned shall be at Vendor's risk and expense.

15. **Right to Cancel:** In addition to any other remedies available to THE COMPANY under this Agreement or applicable law, upon Vendor's breach of this agreement or any Order, THE COMPANY at its option and without liability to Vendor, may forthwith cancel any unshipped portion of any Order.

16. **Advance Shipment:** If THE COMPANY accepts any advance shipment (other than requested by it) under any Order, payment terms on such shipment shall be computed from the prescribed shipping date. Terms on shipments not in advance shall begin when Merchandise is received by THE COMPANY, except that invoices for Merchandise received on and after the 25th of the month will be considered received as of the first of the following month.

17. **Shipping Charges:** Vendor shall pay all charges for packing, crating and shipping unless THE COMPANY expressly agrees to pay such charges.

18. **Freight on Board THE COMPANY:** Except for Freight on Board (F.O.B.) origin Orders, title to the Merchandise ordered hereunder, as well as all risks of loss therefore, shall remain in Vendor until the Merchandise reaches the directed point of destination and is signed for by THE COMPANY's authorized representative. For F.O.B. origin Orders, title and risk of loss shall remain in Vendor until the Merchandise is received by the carrier designated by THE COMPANY.

19. **Additional Expenses:** Unless THE COMPANY otherwise agrees in writing, any additional expense resulting from any delay, partial shipment, early shipment, change of routing, variation of cubic density, change of pack or other failure by Vendor to comply with the terms of this Agreement or the applicable Order shall be paid by Vendor.

20. **Right to Deduct Monies Owed:** THE COMPANY reserves the right to deduct from any amount due Vendor for Merchandise, ordered any amount Vendor owes THE COMPANY with respect to any claims of any nature whatsoever in favor of THE COMPANY against Vendor, whether or not related to the Order and whether now existing or hereafter arising, and any assignee of the Vendor's rights to payment hereunder shall be subject to THE COMPANY's rights under this paragraph.

21. **Right to Withhold Payment:** THE COMPANY reserves the right to withhold any payments due Vendor, without penalty or forfeiture, until all disputes whether or not related to the Order and whether or not existing or arising in the future between THE COMPANY and Vendor, are settled.

22. **Bankruptcy:** Any sums payable to Vendor shall be subject to all claims and defenses of THE COMPANY, and THE COMPANY may deduct and set off against any such sums all present and future indebtedness of Vendor to THE COMPANY. In addition to the foregoing set off rights between THE COMPANY and Vendor, THE COMPANY shall be entitled to set off all obligations it owed Vendor, Vendor's divisions, departments, subsidiaries, affiliates and other related entities (the "Related Entities") against any claims THE COMPANY may have against any or all of the Related Entities, as if: (i) a debt existed from THE COMPANY to the Related Entities or any one of them, (ii) THE COMPANY had a claim against the Related Entities or any one of them, and (iii) the debt and the claim are mutual obligations. For the purpose of this section, Vendor and each of the Related Entities expressly consent to the set off rights afforded herein as they affect the Related Entities. The parties further agree that these set off rights will be applicable and fully enforceable in the event Vendor or any of the Related Entities commence a voluntary bankruptcy proceeding or become the subject of an involuntary bankruptcy petition under Title 11 of the United States Code. THE COMPANY shall provide a copy of the deduction statements for debt it has taken against the Vendor's account as a result of any deductions or set offs. Vendor shall be deemed to have accepted each such deduction or set off unless Vendor, within 90 days of receipt of the deduction statement notifies THE COMPANY in writing as to why a deduction or set off should not be taken and provides documentation of the reason(s) given. THE COMPANY shall not be liable to Vendor for any related interest of late charges pending resolution of the contested set off. In the event that either a voluntary or involuntary bankruptcy petition is commenced by or against Vendor and/or any of the Related Entities under the Title 11 of the United States Code, or under any other federal or state law governing the reorganization, liquidation, assignment for the benefit of creditors, or other similar disposition of Vendor or the Related Entities, Vendor and the Related Entities unconditionally and irrevocably consent, to the relief from the automatic stay so as to allow THE COMPANY to exercise its rights and remedies under the Agreement, including but not limited to exercising its right of set off as set forth herein. In such event, Vendor and the Related Entities hereby agree that they shall not, in any manner, oppose or otherwise delay any motion filed by THE COMPANY for relief from the automatic stay. The provisions of this section constitute a material inducement for Vendor and THE COMPANY to enter into any agreement.

23. **Intellectual Property:** All Merchandise, Proprietary Rights and Confidential Information which are supplied by THE COMPANY or which are distinctive of THE COMPANY's private label or licensed label merchandise or which contain any Proprietary Rights of THE COMPANY or which are created at the request of THE COMPANY (collectively "Special Features") shall be the property of THE COMPANY as "works-made-for-hire" ("Licensed Material") shall be used by Vendor only for THE COMPANY for THE COMPANY's benefit, provided, however, that in the event that Vendor is deemed to have any rights in the Licensed Material, Vendor hereby assigns to THE COMPANY absolutely and exclusively all of Vendor's right, title and interest in the Licensed Material, throughout the Universe in perpetuity (or for the full time period otherwise permitted under local law), in all languages. In the event any right, title, or interest in any of the Licensed Material is not transferred to THE COMPANY by operation of assignment, Vendor hereby grants to THE COMPANY or its designee an exclusive, transferable, sublicensable, Universe-wide, paid-up, royalty-free and irrevocable license to use, exploit and sublicense any and all Licensed Material and related intellectual property rights, whether or not copyrightable, patentable or otherwise protectable under applicable Law, in perpetuity (or for the full time period otherwise permitted under local Law), in all languages. All goodwill accruing shall be for and inure to the benefit of THE COMPANY. All intellectual property associated with Merchandise created by Vendor which includes Special Features, THE COMPANY Proprietary Information or which was created at the request of THE COMPANY shall be and hereby is assigned to THE COMPANY. THE COMPANY may use Special Features as it sees fit on or with respect to goods manufactured by others. Merchandise with Special Features which is not delivered to THE COMPANY for any reason shall not be sold or transferred to any third party without THE COMPANY's prior written authorization, and unless and until all labels, tags, packaging and markings making use of the Special Features or otherwise identifying the Merchandise to THE COMPANY have been removed. Vendor shall defend, indemnify and hold THE COMPANY and its officers and shareholders, agents and employees, harmless from and against all costs, expenses, liabilities and losses reasonably incurred (including reasonable attorneys' fees and associated legal

costs) arising out of any claim of any violation of personal or property rights based on, or in connection with, the actual sale, offer to sell, use or importation of any material, Merchandise, or any other thing used, created, supplied, manufactured, or obtained by Vendor in connection with Vendor's performance under this Agreement.

24. **Advertisement:** The parties hereto agree that if Vendor has represented that it will publicly advertise the Merchandise in accordance with a proposed schedule and thereafter Vendor shall, without the prior written approval of THE COMPANY, fail to advertise Merchandise in accordance with such schedule, THE COMPANY may return such Merchandise to Vendor and may charge the Vendor with the cost of transportation, shipping, unpacking, examining, repacking, reshipping and other like expenses. Any claims for failure to advertise the Merchandise in accordance with such schedule made by THE COMPANY shall be charged back to Vendor and the amount thereof deducted from payments to be made to Vendor or, alternatively, to be promptly refunded to THE COMPANY. ANY ADVERTISING THAT WILL USE ANY PROPRIETARY RIGHTS OF THE COMPANY IS SUBJECT TO PRIOR WRITTEN APPROVAL OF THE COMPANY, AS FURTHER DESCRIBED IN THE COMPANY VENDOR STANDARDS MANUAL.

25. **Indemnification:** Vendor shall indemnify, defend and hold THE COMPANY harmless from and against any and all alleged, actual or threatened liability, claim, loss or damage arising in any way whatsoever out of or in connection with the sale, advertising, possession, handling, use, importation, manufacture, display, misuse, resale, labeling or return of the Merchandise ordered (and if the Merchandise shall include the sales of services, the provision of such services). Vendor shall defend every suit that may be brought against THE COMPANY by reason of any of the foregoing, whether meritorious or not, and shall pay all expenses and fees of counsel which shall be incurred in connection with such defense, together with all costs, damages and any other sums recoverable in every such suit or settlement thereof. If Vendor fails to take timely action to defend such a suit, THE COMPANY may defend such suit at Vendor's expense. THE COMPANY, in addition to any other rights, may forthwith cancel any unshipped portion of the Order and return prior deliveries to Vendor for payment or credit. With respect to any claims falling within the scope of the foregoing indemnifications, Vendor agrees to keep THE COMPANY fully advised with respect to such claims and the progress of any suits. Additionally, THE COMPANY shall have the right to participate, at Vendor's expense, in any suit instituted against it, and to designate attorneys to defend it. Any designated attorneys shall be independent of attorneys chosen by Vendor relating to such claim or any related claim. Vendor is not to settle, compromise or otherwise enter into any agreement regarding the disposition of any claim against THE COMPANY without the written consent and approval of THE COMPANY.

26. **Restricted Products:** Vendor acknowledges and agrees that it shall take all steps necessary to restrict products that it purchases from THE COMPANY from being offered for sale within those jurisdictions that have enacted any law or regulation which prevent their sale (the "Restricted Products"). Vendor hereby agrees to indemnify THE COMPANY and undertake to defend and hold THE COMPANY harmless from and against any liabilities or expenses of any nature or description whatsoever arising out of its failure to prevent Restricted Products from being sold within such jurisdictions.

27. **Confidentiality:** "Confidential Information" means nonpublic information that THE COMPANY designates as being confidential or which, under the circumstances surrounding disclosure ought to be treated as confidential by Vendor. Confidential Information includes, without limitation, information in tangible or intangible form relating to and/or including released or unreleased THE COMPANY products, the marketing or promotion or any THE COMPANY product, THE COMPANY's business policies or practices, and information received from others that THE COMPANY is obligated to treat as confidential. Confidential Information shall not include any information, however designated, that i) is or subsequently becomes publicly available without Vendor's breach of any obligation owed to THE COMPANY; (ii) became known to Vendor prior to THE COMPANY's disclosure of such information to Vendor pursuant to the terms of this Agreement; (iii) became known to Vendor from a source other than THE COMPANY other than by the breach of an obligation of confidentiality owed to THE COMPANY; or (iv) is independently developed by Vendor. Vendor shall refrain from disclosing any Confidential Information to third parties. Vendor shall take reasonable security precautions, at least as great as the precautions it takes to protect its own confidential information, but no less than reasonable care, to keep confidential the Confidential

Information or any other breach of this Agreement by Vendor and its employees and consultants, and will cooperate with THE COMPANY in every reasonable way to help THE COMPANY regain possession of the Confidential Information and prevent its further unauthorized use or disclosure. Vendor shall, at THE COMPANY's request, return all originals, copies, reproductions and summaries of Confidential Information and all other tangible materials and devices provided to Vendor as Confidential Information, or at THE COMPANY's option, certify destruction of same. Vendor acknowledges that monetary damages may not be a sufficient remedy for unauthorized disclosure of Confidential Information and that THE COMPANY shall be entitled, without waiving any other rights or remedies, to such injunctive or equitable relief as may be deemed proper by a court of competent jurisdiction.

28. Liability Insurance: Vendor shall purchase and maintain, at its sole cost and expense, Comprehensive General Liability insurance including Products Liability coverage with limits of not less than \$2,000,000 Combined Single Limit each occurrence Bodily Injury and Property Damage, General Aggregate \$4,000,000 per year. Such insurance shall be carried by an insurer with an A.M. BEST rating of A VII or better. Coverage shall include Broad Form Property Damage, Contractual Liability including Defense Costs, Cross Liability exclusion deleted, Personal/Advertising liability and shall provide Waivers of Subrogation. Vendor agrees to continuously maintain such insurance for the period during which any party may, as a matter of law, be entitled to assert a claim against any Indemnified Party. To the extent Vendor shall be providing delivery or other services to THE COMPANY, Vendor shall provide evidence of automobile coverage as well as Worker's Compensation and Employer's Liability evidencing the coverage to applicable statutory limits and Employer's Liability to limits of \$1,000,000. The insurance company issuing such policy shall bear endorsements to the effect that THE COMPANY shall be notified not less than thirty (30) days in advance of modification or cancellation thereof (except that such notice shall be 10 days in advance for nonpayment of premium) by certified mail to THE COMPANY Attention: THE COMPANY Logistics/Vendor Relations. The policy shall also bear endorsements naming THE COMPANY and Party City as additional insureds under the Broad Form Vendors Endorsement. A renewal certificate evidencing the insurance coverage required pursuant to this Agreement shall be provided to THE COMPANY at least thirty (30) days prior to the expiration of the policy. **Vendor shall furnish to THE COMPANY a certificate of insurance evidencing such insurance within thirty (30) days following commencement of this Agreement.** Vendor specifically agrees that the indemnities referenced in this Agreement are not limited to the insurance coverage set forth in this paragraph. Vendor/and/or Vendor's representatives', insurers' or agents' failure to comply with the insurance of this Agreement shall be considered a breach of this Agreement.

29. Additional Work Performed: All work performed by Vendor and all materials used in connection with any Order shall be at the risk and expense of Vendor until delivered and accepted by THE COMPANY. If any Order calls for work to be performed by Vendor upon any premises owned or controlled by THE COMPANY, Vendor shall keep such premises and work free and clear of all liens and shall furnish THE COMPANY with any certificate, affidavit or waiver as provided by law. Whenever Vendor has in its possession any of THE COMPANY's property, Vendor shall be deemed an insurer thereof and shall be responsible for its safe return to THE COMPANY.

30. Foreign Compliance: Vendor will not offer or give any gratuity or other compensation to induce any person or entity to enter into, execute or perform any services or deliver or purchase any products, in each case, in violation of any law, rule or regulation in the United States or any other jurisdiction throughout the world where Vendor may do business. Vendor represents that it has knowledge and understanding of the Foreign Corrupt Practices Act of the United States of America, as amended ("FCPA"), including any and all obligations and regulations promulgated thereunder, as well as all similar laws, rules and regulations in any jurisdiction where Vendor may do business (including but not limited to the UK Bribery Act). Vendor represents, warrants and covenants that no principal, partner, shareholder, member, officer, director agent, contractor or employee of Vendor is or will become an official of any governmental body of any country in which THE COMPANY may receive or obtain products or service from Vendor (or otherwise do business with Vendor) or any person or entity identified to THE COMPANY by Vendor. Vendor shall not, in the conduct of its performance to provide products or services to THE COMPANY, and with regard to any funds, assets, or records relating thereto, offer, pay, give, or promise to pay or give, directly or indirectly, any payment or gift of any money or thing of value to (i) any

government official (including, without limitation, any officer or employee of a government at any level or of a controlled enterprise thereof or of a public international organization, or a person acting in official capacity for or on behalf of such government or public international organization, or a candidate for political office or a political party or party official) to influence any acts or decisions of such official or to induce such official to use his influence with the local government to effect or influence the decision of such government in order to assist that party in its performance of its obligations under this Agreement or to the benefit of the other party; (ii) any political party or candidate for public office for such purpose; or (iii) any person if that party knows or has reason to know that such money or thing of value will be offered, promised, paid, or give, directly or indirectly, to any official, political party or candidate for such purpose. If Vendor violates the FCPA, THE COMPANY may terminate its relationship with Vendor immediately without notice and without liability, and the business relationship between Vendor and THE COMPANY shall, in the event of termination by THE COMPANY hereunder, be rendered void.

31. Jurisdiction and Venue: Vendor consents to the jurisdiction of, and agrees that any suit, action or proceeding arising out of or in any way related to the Merchandise shall be brought in the courts of the State of New York or the United States District Courts for the District of New York. Vendor waives any objection it may have to the venue or forum of any such controversy that is brought in the aforementioned courts and waives any claim that any such controversy has been brought in an inconvenient forum and consents to the jurisdiction of the aforesaid New York Courts.

32. Taxes: Except as otherwise provided herein, and unless prohibited by statute, Vendor shall pay any federal, state or local use tax, transportation excise tax, or other tax which may be imposed in connection with the performance of the Order.

33. Waiver: THE COMPANY's failure to insist on strict performance of any term or terms hereunder shall not constitute a waiver of any term or default by Vendor. Any waiver of any breach or default hereof shall not constitute a waiver by THE COMPANY of any other or subsequent breach or default of Vendor.

34. Resale:

- (a) THE COMPANY acknowledges that it holds valid resale numbers in all states where THE COMPANY is licensed to do business (excluding states not recognizing sales for resale as sales tax exempt).
- (b) Vendor shall furnish THE COMPANY (attention to: THE COMPANY's Tax Department), when required by law, with the appropriate exemption certificate which shall be completed by THE COMPANY and returned to Vendor. THE COMPANY's "Blanket Resale Certificate" may be substituted by THE COMPANY, if permitted by law.

35. Miscellaneous:

Vendor agrees that it will not offer employment to, employ, hire or otherwise engage the services of any person who is or has been, within the preceding 180 days, an employee of THE COMPANY.

Vendors must limit communication to stores, store specific/franchisee specific issues only. All general communication must be made through THE COMPANY Corporate office.

Vendor shall not offer or provide to any THE COMPANY Associate any gifts, gift certificates, discounts, gratuities, services or any other item of value. Any deviation from this policy could result in the termination of Vendor's relationship with THE COMPANY. All exceptions must receive prior written approval by THE COMPANY's CEO or CFO.

To report issues regarding accounting, internal accounting controls or other business conduct matters, including any inappropriate associate comments, please call the Vice President of Inventory Management at 973-453-8600 or the Vice President, General Counsel and Secretary at 914-784-4188. Any calls or comments will be handled in a confidential manner.

Section - 10

Code of Business Practices

The Company is concerned about human rights, ethical behavior, **the environment**, and compliance with anti-bribery laws and expects our vendors to share our concerns. By agreeing to the terms and conditions of this VSM, you are also committed to the following as summarized in the PCHI Supplier Code of Conduct enclosed in the Appendix of this VSM:

Labor Practices

- Working hours per week, wages, and overtime practices comply with the standards set by law or, in the absence of a law, address humane, safe and productive working conditions; and
- No one under the legal minimum age is employed in any stage of manufacturing; that a minimum age of 14 applies in all circumstances, but not withstanding the forgoing, that C138 Minimum Age Convention (1973) and C182 Worst Form of Child Labour Convention (1999) of the International Labour Organization apply; and
- No forced or prison labor is employed¹, that workers are free to leave once their shift ends, and that guards are posted only for normal security reasons; and
- All workers are entitled to sick or maternity benefits as provided by law; and
- All workers are entitled to freely exercise their rights of employee representation, as provided by law.

The Workplace

- Factories provide a safe working environment for their employees and comply with or exceed all applicable local laws concerning sanitation and risk protection; and
- Factories are properly lighted and ventilated and that aisles and exits are accessible at all times; and
- There is adequate medical assistance available in emergencies, and that designated employees are trained in its use; and
- Protective equipment is available and employees are trained in its use
- Safeguards on machinery meet or exceed local laws; and
- There are adequate toilet facilities which meet local hygiene requirements, and they are properly maintained; and
- There are facilities or appropriate provisions for meals and other breaks; and

¹ Many countries recognize that prison labor is essential to the rehabilitation process. This provision prohibits the exportation of prison-made goods to countries that prohibit or restrict the importation of such goods.

- If a factory provides housing for its employees, it will ensure that dormitory rooms and sanitary facilities meet basic needs, are adequately ventilated and meet fire safety and other local laws; and
- No mental or physical disciplinary practices are employed.

Anti-Bribery Policy

PCHI operates a zero tolerance policy in relation to acts of bribery committed by any person or organization acting on its behalf anywhere in the world, including our vendors. This includes bribes of any type or amount as well as “facilitation payments” (payments made to officials as a bribe to secure or expedite the performance of a routine or necessary action or level of service), which are strictly prohibited by the Foreign Corrupt Practices Act and/or the UK Bribery Act.

Our vendors MUST NOT:

- give, offer or promise any bribe to any third party (including companies, partnerships, government departments or agencies or employees);
- give, offer or promise any bribe to PCHI or any person employed or engaged by PCHI; or
- seek, request or obtain any bribe from PCHI or any third party.

Our vendors MUST:

- operate adequate procedures to prevent any company, individual or other individual associated with them from giving, offering, obtaining or requesting bribes on their behalf;
- operate appropriate “whistle-blowing” procedures so that members of staff who believe or suspect that any bribes have been offered or given, are able to report this internally;
- inform PCHI in the event of any breach of the Policy; and
- cooperate with investigations carried out by PCHI into actual or suspected fraudulent behavior, including violations of anti-bribery regulations, and grant representatives of PCHI access to records and employees for purposes of investigating actual or suspected fraudulent behavior.

Any breach of this policy will be deemed to be a material breach.

Social Compliance

- Vendors must comply with the PCHI’s Supplier Code of Conduct, included in Appendix. This Code sets forth requirements for suppliers of our products with respect to labor standards and working conditions. The principles embodied in our Code are designed to be consistent with core conventions of the International Labor Organization (ILO), the specialized agency of the United Nations focused on global labor standards, codes set forth by key labor standards organizations, as well as codes required by brands, retailers, and licensors who are customers of PCHI.
- PCHI’s Supplier Code of Conduct code should be posted and/or made available to all employees in the local language;
- Adherence by a supplier to this Code also means complying in all respects with the “WRAP (Worldwide Responsible Apparel Producers) -Universal Code” or any comparable, generally recognized equivalent, and providing to PCHI, upon request, an acceptable independent, third-party audit of the facility and their level of compliance with the PCHI Supplier Code of Conduct.



PCHI reserves the right to take all appropriate measures, in accordance with applicable terms and conditions, against any vendor or supplier that fails to comply with this code. (Please refer to Section 4b for social compliance requirements. Examples of acceptable audits include ICTI, WRAP, SA8000, SEDEX, BSCI, WCA, **Better Work Programme**, or other equivalent audit standard put forth by major retailers, licensors, or consumer brands.)

Sustainability

PCHI is committed to supporting conditions under which people and nature can productively co-exist through a collection of mutually beneficial measures. The following summarizes some of the daily measures that PCHI takes to encourage global sustainability among its suppliers and customers:

- Energy, land, air, and water resource usage efficiency in facilities and processes
- Environmental conservation and compliance
- Increased use of recycled and recyclable materials in product and packaging
- Responsible sourcing of timber products, including FSC-certified material
- Reduction of packaging materials
- Use of renewable resources, such as sugar cane, corn, and bamboo
- Minimization of waste at company-owned facilities

As a supplier to PCHI, we encourage you to develop products and packaging that benefit the environment and keep us informed of any sustainability measures or programs which would have as large a positive impact as possible.



Party City Contact Information

Merchandise / Accounts Payable			
Merchandise Payables Correspondence		accountspayable@partycity.com	973-453-8736
Don Chapin	Controller	dchapin@partycity.com	973-453-8787
Mike Penncavage	Assistant Controller	mpenncavage@partycity.com	973-453-8756
Alissa Barrett	Accounts Payable Manager	abarrett@partycity.com	973-453-8610
Electronic Data Interchange (EDI)			
EDI Correspondence		edisupport@partycity.com	
Nancy Higgins	EDI Specialist	nhiggins@partycity.com	973-453-8641
Patty Madden	EDI Specialist	pmadden@partycity.com	973-453-8765
Expense Payables			
Mike Penncavage	Assistant Controller	mpenncavage@partycity.com	973-453-8756
Alissa Barrett	Accounts Payable Manager	abarrett@partycity.com	973-453-8610
Amanda Margotta	Expense Payable Supervisor	amargotta@partycity.com	973-453-8864
Amscan/Party City Logistics			
Andrew Medrick	SVP of Supply Chain and Transportation	amedrick@partycity.com	973-453-8613
Jaime Perez	Transportation Manager	jperez@partycity.com	973-453-8718
Jamie Wohlrabe	Transportation Routing	jwohrlabe@partycity.com	973-453-8786
Peggy O'Brien	Imports	mobrien@partycity.com	973-453-8788
Fran Clark	Imports	fclark@amscan.com	914-784-4135
Corporate New Store Merchandise Purchase Orders			
Caryl Kalman	New Store Correspondence	ckalman@partycity.com	973-453-8878
Franchise New Store Merchandise Purchase Orders			
Terry Nolan	Franchise New Stores	tnolan@partycity.com	973-453-8668
Product Safety/Testing/Quality Assurance			
Hsin Chen	Product Compliance Manager	hchen@amscan.com	914-784-4057 or 973-453-8935 (p)
Purchase Orders (Everyday and Seasonal)			
PO Confirmation	PO Administrator	POConfirm@partycity.com	973-983-4927 (f)
Vendor Relations			
Vendor Relations Correspondence		vendorrelations@partycity.com	973-983-4915 (f)
Party City Corporate Address			
Party City Corporation 25 Green Pond Road, Suite 1 Rockaway, NJ 07866			



Amscan Contact Information

Vendor Relations			
Vendor Relations Correspondence		vendorrelations@amscan.com	914-784-4302 (f)
<i>Joseph Iuso</i>	Vendor Relations Coordinator	jiuso@amscan.com	914-784-4075 (p) 914-784-4302 (f)
Kim Aldrich	Quality Control Supervisor	kaldrich@amscan.com	845-469-9116 (p) 845-572-2178 (f)
Amscan/Party City Logistics			
<i>Mary Lynn Slusher</i>	Director of Distribution	mlsruher@amscan.com	845-469-9116 (p) 845-469-5576 (f)
Andrew Medrick	SVP of Supply Chain and Transportation	amedrick@amscan.com	973-453-8613
Bill Bennett	Receiving Manager DC	bbennett@amscan.com	845-469-9116
Sandie Marciano	Sr Manager Transportation DC	smarciano@amscan.com	845-572-2128
Jaime Perez	Transportation Manager	jperez2@amscan.com	973-453-8718
Jamie Wohlrabe	Transportation Routing	jwohrlabe@amscan.com	973-453-8786
Peggy O'Brien	Imports	mobrien@amscan.com	973-453-8788
Fran Clark	Imports	fclark@amscan.com	914-784-4135
Accounts Payable			
Mary Ann Sabia	Accounts Payable Manager	msabia@amscan.com	914-784-4039 (p) 914-784-4382 (f)
Inventory			
Jim Dotti	Inventory Manager	jdotti@amscan.com	914-784-4011 (p) 914-345-8684/8685 (f)
Product Development / By-Pass			
Eric Stollman	VP – Sourcing	estollman@amscan.com	914-784-4106 (p) 914-345-8431 (f)
Cherry Yuen	Sr Product Development & Merchandising Manger	cyuen@amscan.asia	011-852-3655-9206 (p) 011-852-2155-1511 (f)
Deborah Warren	Director of Product Development (By-Pass)	dwarren@amscan.com	914-784-4290 (p)
Polly Hui	Asia Supply Chain	phui@amscan.asia	011-852-3655-9209
Winfred Wong	Asia Supply Chain	wwong@amscan.asia	011-852-3655-9148
Product Safety/Testing / Quality Assurance			
Patrick Chan (Asia)	Manager- Product Safety & Compliance	pchan@amscan.asia	011-852-3655-9185 (p)
Maryann Inzalaco	Product Integrity Administrator	minzalac@amscan.com	914-784-4010 (p) 914-784-8853 (f)
Amscan Corporate Address		Amscan Asia International Ltd Office Address	
Amscan Inc 80 Grasslands Road Elmsford, NY 10523		Amscan Asia International Ltd 35/F and 36/F, Saxon Tower 7 Cheung Shun Street Lai Chi Kok , Kowloon Hong Kong	



Grasslands Road Contact Information

Vendor Relations			
Vendor Relations Correspondence		vendorrelations@amscan.com	914-784-4302 (f)
Joseph Iuso	Vendor Relations Coordinator	jiuso@amscan.com	914-784-4075 (p) 914-784-4302 (f)
Kim Aldrich	Quality Control Supervisor	kaldrich@amscan.com	845-469-9116 (p) 845-572-2178 (f)
Amscan/Party City Logistics			
Mary Lynn Slusher	Director of Distribution	mslusher@amscan.com	845-469-9116 (p) 845-469-5576 (f)
Andrew Medrick	SVP of Supply Chain and Transportation	amedrick@amscan.com	973-453-8613
Bill Bennett	Receiving Manager	bbennett@amscan.com	845-469-9116
Jaime Perez	Transportation Manager	jperez2@amscan.com	973-453-8718
Jamie Wohlrabe	Transportation Routing	jwohlrabe@amscan.com	973-453-8786
Peggy O'Brien	Imports	mobrien@amscan.com	973-453-8788
Fran Clark	Imports	fclark@amscan.com	914-784-4135
Accounts Payable			
Mary Ann Sabia	Accounts Payable Manager	msabia@amscan.com	914-784-4039 (p) 914-345-8327 (f)
Inventory			
Jim Dotti	Inventory Manager	jdotti@amscan.com	914-784-4011 (p) 914-345-8684/8685 (f)
Hong Kong Gift Operations			
Amy Davis	Director of Product Development	adavis@amscan.com	914-784-4044 (p) 914-345-8448 (f)
Maria Rubeo	Director of Product Development	mrubeo@amscan.com	914-784-4052 (p) 914-345-8448 (f)
Winnie Sze	Merchandising Manager	wsze@amscan.asia	011-852-3655-9218 (p) 011-852-2155-1511 (f)
Product Safety/Testing /Quality Assurance			
Patrick Chan (Asia)	Manager- Product Safety & Compliance	pchan@amscan.asia	011-852-3655-9185 (p)
Maryann Inzalaco	Product Integrity Administrator	minzalac@amscan.com	914-784-4010 (p) 914-784-8853 (f)
Amscan Corporate Address		Amscan Asia International Ltd Office Address	
Amscan Inc/Grasslands Road 80 Grasslands Road Elmsford, NY 10523		Amscan/Grasslands Road Hong Kong 35/F and 36/F, Saxon Tower 7 Cheung Shun Street Lai Chi Kok , Kowloon Hong Kong	

HALLOWEEN CITY

So Much For So Little, It's Spooky!

Halloween City Contact Information

Merchandising			
Melissa Sprich	VP of Merchandising	halloweenteam@partycity.com	973-453-8867
Logistics			
Steve O'Toole	Logistics Manager	sotoole@halloweencity.com	734-591-1717 x5418
Lisa Foster	General Manager of Distribution Center	lfoster@halloweencity.com	734-591-5456
Accounts Payable			
Alissa Barrett	Accounts Payable Manager	abarrett@partycity.com	973-453-8610
Product Safety/Testing/Quality Assurance			
Hsin Chen	Product Compliance Manager	hchen@amscan.com	914-784-4057 or 973-453-8935
Halloween City Corporate Address			
Gags and Games, Inc. d/b/a Halloween City 35901 Veronica Livonia, MI 48150			



Party City Canada Contact Information

Executive Offices			
Reggie Pan	Vice President	rpan@partycity.ca	416-631-8455 x345
Romina Torre	Director of Merchandising	rtorre@partycity.ca	416-631-8455 x326
Purchasing / Merchandising			
Paula Stephens	Category Manager	pstephens@partycity.ca	416-631-8455 x320
Gina Ferguson	Category Manager	gferguson@partycity.ca	416-631-8455 x348
Logistics			
*has not been replaced			
Accounts Payable			
Alissa Barrett	Accounts Payable Manager	abarrett@partycity.com	973-453-8610
Product Safety/Testing /Quality Assurance			
Romina Torre	Director of Merchandising	rtorre@partycity.ca	416-631-8455 x326
Party Packagers Corporate Address			
Party City Canada 67 Alexdon Rd Toronto, Ontario, Canada M3J 2B5			



Anagram International Contact Information

Executives			
Jim Plutt	President	jplutt@anagramintl.com	952-949-5632
Paul Ansolabehere	Vice President Operations	ansolabp@anagramintl.com	952-949-5745
Chris Wiles	Controller	wilesc@anagramintl.com	952-949-5676
Mark Harbert	Vice President of U.S. and Canadian Sales	mharbert@anagramintl.com	918-298-1642
Cindy Mark	VP Logistics and IT	cmark@anagramintl.com	952-949-5740
Mark Sifferlin	VP Marketing-Amscan/Anagram	msifferlin@anagramintl.com	952-949-5760
Vendor Relations / Purchasing / Merchandising			
Jeff Puth	Purchasing Manager	jputh@anagramintl.com	952-949-5638
Paul Sable	V.P. Marketing	psable@anagramintl.com	952-949-5729
Helen Phillips	Quality Manager	hphillips@anagramintl.com	952-949-5818
Logistics			
Mike Longberg	Distribution Center Manager	mlongberg@anagramintl.com	952-949-5865
Adrian Peers	Warehouse Supervisors	apeers@anagramintl.com	952-949-5647
Accounts Payable			
Kathy Swendiman	Accounts Payable	swendimk@anagramintl.com	952-949-5705
Product Safety/ Testing / Quality Assurance			
Helen Phillips	Quality Manager	hphillips@anagramintl.com	952-949-5818
Christin Conroy	Product Safety Coordinator	cconroy@anagramintl.com	952-949-5653
Anagram International Corporate Address			
Anagram International 7700 Anagram Drive Eden Prairie, MN 55344			



NOBODY HAS MORE PARTY FOR LESS

Partycity.com Web Fulfillment Center

Chief Operating Officers			
Ed Plesa	VP Supply Chain Management	eplesa@amscan.com	630-579-2070
Dan Moecher	Director of Operations	dmoecher@amscan.com	630-579-2095
Lisa Kruse	Director of Inventory Control	lkruse@amscan.com	630-579-2157
Logistics			
Dennis Delaney	Receiving Supervisor	ddelaney@amscan.com	630-579-2067
Receiving Appointments			
			630-579-2084
			630-579-2067
Fulfillment Center Address			
Party City 2727 Diehl Road Naperville, IL 60563 630.579.2000			

Section – 12 (Retail)

Personalization and Custom Invitation

In Store Custom Albums

Vendors are to provide a complete album based on agreed purchasing terms outlined on the Vendor Participation Agreement (VPA). Each album must include a price list covering all items charged for any additional services or custom requests in an easy to understand, clear format for the stores.

Album Updates or Discontinues must be sent to PC corporate for review and approval at least sixty (60) days prior to shipment to the stores.

Price Changes

All updates regarding price changes must be submitted to PC corporate for review and approval. Price changes must be submitted to the Merchandise Manager via email with the revised retail inserts mailed to the MM's attention. Upon approval, all new pricing documents and/or pages must be provided to all stores for active albums prior to any cost changes going into effect. Price change requests must be submitted sixty (60) days prior to effective date.

Order Forms

Vendor is to provide in-store order forms for all stores that carry their albums to include the store specific account number. Any changes must be submitted to PC corporate for review and approval before sending to stores.

Purchase Orders

Purchase orders will be created by each store on the specific vendor order form and faxed directly to the vendors. Any questions regarding these orders must be addressed to the stores who will contact the customer.

Proofs

- All proofs must be faxed directly to the store (not to the customer or to PC corporate)
- Proofs must be faxed to the stores within 24-48 business hours from receipt of order request

Shipments

All orders must be shipped complete and received at the store within 10-14 business days (not including expedited orders) for standard orders. Exceptions may include: special order processing or custom designed orders.

Section – 12 (Retail)

If the order cannot be delivered within the requested timeframe, the store must be notified with 24 hours of their expected receipt and store will contact the customer. Any uncommunicated late shipments will be subject to penalty as listed in the Reimbursement and Waiver Policy, Section 8.

- Each shipping carton should include a detailed packing list for order verification upon delivery at the store.
- All orders are to be shipped directly to the stores (not to the customers or PC corporate office)
- Orders shipping to Puerto Rico and Hawaii must be shipped to the store address, not the S2B2 consolidation address in Florida or California.
- PC will not be responsible for any misprinted orders not matching signed proofs
- PC will not be responsible for any bill backs from Carriers for incorrect shipping addresses. It is the vendors' responsibility to ensure the ship-to-bill-to file is correctly entered in their system.

Invoices

Deliveries to the stores must include a packing list of the items shipped and a copy of the invoice related to the shipment.

In order to process payments, invoices must also be sent to the billing address. Refer to the ship-to-bill-to file for specific bill to information.

Invoices must include itemized cost for each specific item ordered.

For corporate invoices, the preferred method of invoice receipt is an excel spreadsheet that includes all invoices billed to all corporate stores. This spreadsheet should be sent weekly and should represent all invoice billed each week for all corporate stores. This spreadsheet must include the invoice items details that agree, in total, to the net invoice amounts. Please contact merchandise payables to set up this process if you are not already doing so. (Invoice number, PO number, site, invoice date, invoice amount, tracking information and all invoice items details are required for the excel spreadsheet).

In addition, combined monthly statements for all corporate stores, in an excel format, must also be submitted to the merchandise payables department. This will assist in verifying the receipt and processing of all corporate invoices.

Communication

All program communication is to go directly to the PC corporate buying office and will be disseminated to the stores upon approval.

All customer order specific questions or information must be sent directly to the stores. Vendors should never contact a customer directly.

Other Sections to be reviewed and acknowledged by vendor

- Section 4a (Retail) – **Product Safety and Quality Assurance** - Applies to all vendors providing accessories or invitations with embellishments. Must comply with PCHI safety standards.

Section – 12 (Retail)

- Section 6a (Retail) – **Transportation Routing Guide** – Applies to all vendors regardless of Prepaid or Freight Collect shipment terms. Follow rules for DSD Shipping instructions.
- Section 8 – **Reimbursement and Waiver Policy** - Rules in the #800 series specifically for Personalization and Custom Invitation vendors.
- Section 9 – **Terms and Conditions** - required for all PCHI vendors
- Section 10 – **Code of Business Practices** - required for all PCHI vendors
- Section 11 – **Party City Contact Information**

Section - 13 (Retail)

Partycity.com Web Fulfillment Center

Packaging

- Only one SKU per carton is permitted.
- Each master case should be made of durable shippable corrugate.
- Maximum master case size is 20" long x 20" wide x 14" high.
- Preferred master case size is 16" long x 10" wide 9" high
- Maximum master case weight of 50 lbs.
- Do not use loose fill for packaging.
- Standard case packs are required. Each item must have a standard and consistent master case quantity and a standard and consistent inner pack quantity.
- If an item (selling unit) consists of multiple pieces then each piece should be securely packaged within the selling unit packaging. As an example, attaching a mask to the outside of a costume bag is not acceptable.
- Assortments may be shipped in a single carton as long as there is a master ordering SKU for that assortment.
- Hangers for apparel are not allowed.
- **Apparel** product must be packaged **as eaches** in **polybags** or **similar** sealed packaging, with UPC barcode visible without opening up the package. **Apparel products include; T-Shirts, hats, pajama pants, socks, sweaters, scarves, etc.**
- **Plush items such as fabric covered stuffed toy animals and fabric covered toys must be packaged as eaches in polybags or similar sealed packaging. UPC barcode must be visible without opening the package.**

Labeling

Each master case should be labeled with the following human readable information:

Shipping Label

- Ship to
- Ship from
- P.O. number
- Carrier information:
 - Tracking number
 - PRO number
 - BOL number

Section - 13 (Retail)

Labeling Continued

Item description label or printing on master case must contain the following human readable information:

- SKU number and vendor part number of the item contained within
- Description of item
- Quantity contained within and case pack info
- Case pack information

GS1-128 ASN labels should be affixed to the lower right hand corner of the longest side of each box; and should contain ASN information for contents of each carton

A pallet-level ASN label which reflects the entire contents of the pallet to which it is affixed is acceptable as long as all cartons on the pallet have human readable item description and quantity on them.

UPCs

- Each inner pack must be labeled with a valid scannable UPC that is reflective of the item and quantity contained within the inner.
- Each selling unit must be labeled with a valid scannable UPC, which is clearly visible, and is reflective of the individual selling unit.

Packing slips

- A packing slip is required for each shipment.
- One packing list per P.O.
- Packing list should contain the following information:
 - P.O. number
 - List each item, description, SKU or part number
 - Quantity shipped of each item
 - Total cases
 - Total units

Preparation And Packaging For Battery Powered Devices With Batteries Included

The packaging requirements specified in the (attached) DOT Special Provision 130 must be followed for battery powered devices with batteries included.

Section - 13 (Retail)

Deliveries

- Pallets:
 - Shipments in excess of 50 cubic feet must be palletized.
 - Standard GMA 48" x 40" 4-way pallets must be used.
 - Pallets must be grade B or better – no missing, broken or spliced boards
- Only one P.O. is permitted on each bill of lading.
- On multiple P.O. shipments, product must be tendered in a segregated manner (multiple P.O.s must not be mixed on the same pallet).
- Product should be tendered in a sorted and segregated manner. When multiple cases of each item are shipped, they should be shipped on the same pallet.
- Pallets must be stretch wrapped.
- Delivery appointments should be made for any delivery in excess of 200 cases or 2,000 pounds. Call 630-579-2084 or 630-579-2067.

Consumable Items

- All consumable items must be labeled with an expiration date or date code.
- Minimum of 6 months of dating is required upon receipt into the D.C.
- Inner packs must be sealed.

Contact Information

Fulfillment Center: 2727 Diehl Road
Naperville, IL 60563

Receiving Appointments: 630-579-2084 / 630-579-2067

Web Fulfillment Center Management Contact List

Ed Plesa	VP Supply Chain Management eplesa@amscan.com	630-579-2070
Dan Moecher	Director of Operations dmoecher@amscan.com	630-579-2095
Lisa Kruse	Director of Inventory Control lkruse@amscan.com	630-579-2157
Dennis Delaney	Receiving Supervisor ddelaney@amscan.com	630-579-2067
Jessica Meyer	Sr. Supervisor, Inventory Control jmeyer@partycity.com	630-579-2076



Party City Holdings, Inc



2017

Appendix

Glossary

The following is a list of key terms commonly used throughout this guide.

Term	Definition
Advanced Shipping Notice (ASN)	Common term for the 856 Ship Notice/Manifest EDI transaction set. An ASN contains shipping and item information relative to a particular shipment. ASNs enable the recipient to plan for receipt of the shipment and to automate the merchandise receiving process.
Back Order	Any shipments against a Purchase Order (PO) after the first shipment.
Cartons	Enclosed storage unit for product received from a vendor.
Case	An enclosed storage unit for product shipped to a Party City location.
Case pack	The packaging of the same item in multiple quantities. Sometimes referred to as a master pack, # of selling units in a standard vendor carton.
Cube	The length, width and height of an item or container.
CBM	Cubic Meter
Consolidated Freight Station (CFS)	Vendor delivers truck with product to consolidator. Consolidator unloads, warehouses and loads container. Vendor is charged a fee.
Cube utilization	Determined by counting the total cubic feet of materials stored in a Party City location and expressing the number as a percentage of the total cubic dimensions. Using racks to increase storage space can increase cube utilization.
Cubiscan	Accurately measure the weight and dimensions of a carton
CY	Direct to Warehouse - Vendor picks up container and vendor loads container, seals, brings to ocean vessel and loading zone.
DDP	Delivered Duty Paid - Vendors are responsible for delivery to the Party City Corporation Distribution Center (PCC DC) door, including all freight costs, duties, and customs clearance under vendor's own importer of record number. Party City Corporation takes possession of goods upon receipt at our PCC DC locations.
Drayage	The movement or hauling a heavy container or shipment.
Each	A single selling unit.
Electronic Data Interchange (EDI)	The computer-to-computer transmission of documents between two companies. Computer-to-computer implies that all information contained in the document is capable of being read and processed without human intervention.
EDI Service Provider	A company that performs EDI on behalf of its clients. Most service providers offer various levels of EDI services tailored to a client's needs ranging from fax to web based EDI.
EDI Software Provider	A company that markets software solutions (ranging from PC-based solutions to A-400/mainframe based systems) that enable a company to perform EDI transactions in-house. Some software solutions are specifically designed to accommodate Party City's EDI documents. These packages are solely the product and responsibility of the company that markets them.

Term	Definition
Exceptions	Any discrepancies with merchandise that cause a delay with merchandise being processed in the facility (e.g. no allocation, invalid UPCs, and unacceptable substitutions).
Flat	A material handling classification of product, which may be processed and shipped in cartons or totes. Generally apparel and peg board merchandise.
FCA	Free Carrier Alongside
FCR	Forwarder's Cargo Receipt
Floor Ready Merchandise (FRM)	Merchandise that is ready for sale when received.
FOB	Free On Board AKA Port of Origin (POO) - Vendors are responsible for delivery to Party City Corporation's designated freight forwarder at the foreign port. Party City Corporation is responsible for import freight costs and customs clearance and takes possession of goods upon Forwarder Cargo Receipt (FCR) issuance.
Inner Pack	A unit pack that is less than the master pack but larger than the selling unit.
Item setup	Process for establishing a new product in our systemic item file. All items must go through this process prior to being handled.
LDP	Landed Duty Paid AKA Port of Entry (POE) - Vendors are responsible for delivery to the port of entry and can include the terminal railhead located nearest to the PCC DC destination. LDP includes all freight costs and customs clearance under the vendor's own importer of record number. Party City Corporation takes possession of the goods after clearing customs.
License Plate Number (LPN)	A bar-coded label with unique non-repeating numbers used to identify a load of merchandise. Includes the item number, quantity, and location and is put on all totes being moved through a Party City distribution operation.
Loading Term	How product is delivered to forwarder for export
Master Pack	The largest individual packaging unit available. Also known as a case pack.
Merchandise Management System	Allocation system used for inventory management (MMS).
New Vendor	A vendor doing business 90 days or less from the date of their first PO.
New Vendor Package	A grouping of documents (Welcome Letter, VSM, and VPA) sent to a vendor to establish proper vendor relations and documentation.
Non-conveyable items	Items too large to be sent through the sortation system. These items are transported manually to shipping where they are scanned and loaded directly onto an outbound trailer.
Order Create Date	The day that the PO is initiated by a Merchandise Manager or authorized Planning and Allocations associate.
Off-Site Receiving (OSR)	A receiving facility that is separate from a retail location.
POE	Port of Entry – See LDP
POO	Port of Origin – See FOB
PO Receipt	The amount of product received on a specific shipment for a specific SKU to be applied in allocation and replenishment to specific stores. The specific amount of product to be shipped to stores on a single shipment and not spread across multiple shipping days.

Term	Definition
Pallet	A portable platform made of wood, metal, or plastic on which merchandise is stacked to facilitate handling, storing, and transporting with manual or mechanical equipment.
Pre-existing Vendor	A vendor doing business for more than 90 days from the date of their first PO.
Purchase Order (PO)	Information sent to vendors to request merchandise for a specific location. Includes manufacturer item number, quantity, price and discounts, vendor information, and ship-to-information.
Receiving Area	The location where shipments arrive from suppliers and are checked in.
Regional Distribution Center (RDC)	A central receiving and shipping point which processes merchandise for shipments to select stores based on store allocations.
Reimbursement	Deductions against any current or future invoice to recover expenses incurred due to vendor non-compliance.
Requested Ship Date	The day the vendor tenders shipment. The order quantity must match the tendered quantity. Back orders will not be accepted.
Routing	Transporting instructions passed from a Load Control Center to vendors sending product to a Party City distribution location and the sending of product to stores.
Ship To – Mark For	Merchandise that is vendor prepared, floor ready, and picked/packed for a specific store. It is received at a Party City distribution location and shipped to the “marked for” store.
TOPS	Total Optimization Packaging Software
Vendor Participation Agreement (VPA)	Standardized form of Party City requirements for all merchandise trading partners. A current copy must be on file to receive Party City POs.

Breakdown of Party City's Departments

Dept #	Dept Name	Dept #	Dept Name
85	Helium Tank Rental	207	DR. SEUSS
97	Party Goods - Non Taxable	217	Rentals
99	Party Goods - Taxable	218	NFL/Superbowl
101	Mylar Balloons	219	Valentine's Day
102	Baby	220	St. Patrick's Day
103	Wedding	221	Easter/Spring
104	Party Themes	222	Communion/Confirmation
105	Solids	223	Graduation
106	GENERAL ENTERTAINING	224	Patriotic
108	Sports	225	Summer
109	General Decorations	226	HALLOWEEN
110	SERVEWARE	227	Costumes
111	Birthday Bakeware	228	Fall
112	Pinatas	229	Thanksgiving
113	Gift Wrap	230	Hannukah
114	Stationery/Novelties	231	Christmas
115	Birthday Accessories	232	New Years
116	Non Seasonal Candy	236	Specialty Holiday
117	Kids Favors	244	Seasonal Candy
133	Greeting Cards	248	Store Supplies
134	General Birthday	255	COSTUME ACCESSORIES
135	1st Birthday	256	Mardi Gras
137	Kids Birthday		
138	Cocktail Party		
139	General Candles		
140	Rentals		
141	CUSTOM ALBUM		
142	Event Planning		
143	Latex Balloons		
145	PROFESSIONAL SPORTS		
147	INSCRIBE		
148	WEB PERSONALIZATION	350	Non Revenue
149	WEB PERSONALIZED FAVORS	351	Supplies
157	Foil	352	Coupons
158	SPECIAL EFFECTS	353	Other
159	Premium Trim	354	Freight
160	Gifts	399	Aged
162	Color City		
163	FASHION WEARABLES		
164	Toys		

The Party City department listing is accurate as of the release of the 2017 VSM. However, if there are any changes, Party City will notify all of our vendor partners.

Unit of Measure



Carton
Shipping receptacle.

Selling Unit = 1
ALWAYS!



Selling Unit
One (1) unit of sellable product.

Ex: SKU 71073– 50 Ct Forks – Pretty Pink



12 **cartons** on a pallet.



Case Pack

Number of **selling units** in a standard vendor **carton**.

Ex. 12 selling units (4 layers of 3 *selling units*)

	Shipments to PCC DC	Shipments to PCC Store (DSD)
Pack Qty	Number of selling units in a carton for a shipment to a PCC DC. Defined by vendor. Ex. DC Pack Qty = 12 selling units	Number of selling units in a carton for a shipment to a PCC Store. Can be between 1 and the standard vendor case pack qty . Ex. DSD Pack Qty = 1 selling unit
Minimum Order Qty	Minimum number of selling units vendor requires PCC to buy for shipment to a PCC DC. Must be a multiple of the pack qty for PCC DC. Ex. 12 cartons of 12 selling units. DC minimum order qty – 12x12 = 144 selling units	Minimum number of selling units vendor will ship to a PCC store. Typically equals 1 selling unit , but can be greater than 1. Ex. Vendor will not ship any less than 1 selling unit to a store. DSD min order qty = 1 selling unit
Pack Cost	Cost to PCC of PCC DC pack qty Ex. DC Pack Cost = \$2.22 (DC pack cost) / (DC pack qty) = DC selling unit cost \$2.22/12 = \$0.185	Cost to PCC of DSD pack qty Ex. DSD Pack Cost = \$0.185 NOTE: DSD Pack Cost often equals the DC selling unit cost.



Case Pack Dimensions:

Height in inches
 Length/Depth in inches
 Width in inches
 Weight in lbs.

Planogram Dimensions:

POG Height in inches – Top to bottom
 POG Length/Depth in inches – Front to back
 POG Width in inches – Side to Side along the shelf or as pegged item

Add/Edit New Item Information

- Instructions:**
1. Enter new item information into the table below. Each item should be entered on a separate line.
 2. All fields must be completed; "notes" are optional. Shaded cells are calculated and cannot be changed.
 3. To remove a line item, select the "DELETE LINE" button and enter the "Count" number in the popup box. The line will be highlighted for deletion and you can not undo it.
 4. Upon completion of the form, select "Back to Vendor Main Menu" and proceed to Step 3.

Vendor Name:	sample	Date:	
Vendor Number:	9999	Vendor Contact Phone:	999-999-9999
Vendor Contact Person:	Sample	Vendor Contact Email:	Sample@email.com

Count	Description	Vendor Item #	DC Cost				DSD Cost				MSRP	UPC	Mult. UPC	Haz. Mat.	Country of Origin	POG / Product Dimensions			Case Pack Dimensions				Notes
			Pack Qty	Minimum Order Qty	Pack Cost	DC Unit Cost	Pack Qty	Minimum Order Qty	Pack Cost	DSD Unit Cost						Hight (Inches)	Width (Inches)	Depth (Inches)	Hight (Inches)	Width (Inches)	Depth (Inches)	Weight (Lbs.)	
1	Description	12345					1	1	\$1.000	\$1.000	\$2.00	368276121318		No	China	TBD	TBD	TBD	0.00	0.00	0.00	0.00	
														No	China	TBD	TBD	TBD					
														No	China	TBD	TBD	TBD					
														No	China	TBD	TBD	TBD					
														No	China	TBD	TBD	TBD					
														No	China	TBD	TBD	TBD					
														No	China	TBD	TBD	TBD					



QUOTATION SHEET

VENDOR: _____ COUNTRY OF MANUFACTURE: _____

E-MAIL ADDRESS: _____

LINE: _____ ITEM #: _____

DESCRIPTION: _____

MOQ : PCS

SIZE: _____ "L X _____ "W X _____ "H

DATE: _____

F.O.B. _____ / PRICE : \$ 0.000 /PC

FREIGHT* 2.5 /CUFT : #DIV/0!

DUTY% _____ : \$ -

TARRIF # _____

OTHER (SPECIFY) _____

FOB PORT : _____

LANDED COST U.S. \$ #DIV/0! /PC

S.R.P. _____

G.P. _____

PACKING: _____ INNER PACK _____ MASTER CARTON PACK _____
_____ GIFT BOX _____ cube > _____ CUFT/MASTER CTN

_____ OTHER (SPECIFY) _____

_____ DISPLAY (SPECIFY) _____

_____ HANG TAG _____

_____ ASSORTMENT PACK (SPECIFY) _____

1 TIME CHARGES, IF APPLICABLE:
(SPECIFY) _____

REMARKS: _____ ITEM PHOTO

* FOR FREIGHT - LIST CUBIC DIMENSION OF
MASTER CARTON/MASTER CARTON PACK,
THEN CALCULATE FREIGHT PER PC. BASED
ON \$2.50/CU.FT.

JULIAN DATE CALENDAR

(Perpetual, non-leap years)
 (2007, 2009, 2010, 2011, 2013, 2014, 2015, 2017, etc...)

Day	Jan	Feb	Mar	Apr	May	June	July	Aug	Sept	Oct	Nov	Dec	Day
1	001	032	060	091	121	152	182	213	244	274	305	335	1
2	002	033	061	092	122	153	183	214	245	275	306	336	2
3	003	034	062	093	123	154	184	215	246	276	307	337	3
4	004	035	063	094	124	155	185	216	247	277	308	338	4
5	005	036	064	095	125	156	186	217	248	278	309	339	5
6	006	037	065	096	126	157	187	218	249	279	310	340	6
7	007	038	066	097	127	158	188	219	250	280	311	341	7
8	008	039	067	098	128	159	189	220	251	281	312	342	8
9	009	040	068	099	129	160	190	221	252	282	313	343	9
10	010	041	069	100	130	161	191	222	253	283	314	344	10
11	011	042	070	101	131	162	192	223	254	284	315	345	11
12	012	043	071	102	132	163	193	224	255	285	316	346	12
13	013	044	072	103	133	164	194	225	256	286	317	347	13
14	014	045	073	104	134	165	195	226	257	287	318	348	14
15	015	046	074	105	135	166	196	227	258	288	319	349	15
16	016	047	075	106	136	167	197	228	259	289	320	350	16
17	017	048	076	107	137	168	198	229	260	290	321	351	17
18	018	049	077	108	138	169	199	230	261	291	322	352	18
19	019	050	078	109	139	170	200	231	262	292	323	353	19
20	020	051	079	110	140	171	201	232	263	293	324	354	20
21	021	052	080	111	141	172	202	233	264	294	325	355	21
22	022	053	081	112	142	173	203	234	265	295	326	356	22
23	023	054	082	113	143	174	204	235	266	296	327	357	23
24	024	055	083	114	144	175	205	236	267	297	328	358	24
25	025	056	084	115	145	176	206	237	268	298	329	359	25
26	026	057	085	116	146	177	207	238	269	299	330	360	26
27	027	058	086	117	147	178	208	239	270	300	331	361	27
28	028	059	087	118	148	179	209	240	271	301	332	362	28
29	029		088	119	149	180	210	241	272	302	333	363	29
30	030		089	120	150	181	211	242	273	303	334	364	30
31	031		090		151		212	243		304		365	31

JULIAN DATE CALENDAR

For Leap Years Only
(2004, 2008, 2012, 2016, etc...)

Day	Jan	Feb	Mar	Apr	May	June	July	Aug	Sept	Oct	Nov	Dec	Day
1	001	032	061	092	122	153	183	214	245	275	306	336	1
2	002	033	062	093	123	154	184	215	246	276	307	337	2
3	003	034	063	094	124	155	185	216	247	277	308	338	3
4	004	035	064	095	125	156	186	217	248	278	309	339	4
5	005	036	065	096	126	157	187	218	249	279	310	340	5
6	006	037	066	097	127	158	188	219	250	280	311	341	6
7	007	038	067	098	128	159	189	220	251	281	312	342	7
8	008	039	068	099	129	160	190	221	252	282	313	343	8
9	009	040	069	100	130	161	191	222	253	283	314	344	9
10	010	041	070	101	131	162	192	223	254	284	315	345	10
11	011	042	071	102	132	163	193	224	255	285	316	346	11
12	012	043	072	103	133	164	194	225	256	286	317	347	12
13	013	044	073	104	134	165	195	226	257	287	318	348	13
14	014	045	074	105	135	166	196	227	258	288	319	349	14
15	015	046	075	106	136	167	197	228	259	289	320	350	15
16	016	047	076	107	137	168	198	229	260	290	321	351	16
17	017	048	077	108	138	169	199	230	261	291	322	352	17
18	018	049	078	109	139	170	200	231	262	292	323	353	18
19	019	050	079	110	140	171	201	232	263	293	324	354	19
20	020	051	080	111	141	172	202	233	264	294	325	355	20
21	021	052	081	112	142	173	203	234	265	295	326	356	21
22	022	053	082	113	143	174	204	235	266	296	327	357	22
23	023	054	083	114	144	175	205	236	267	297	328	358	23
24	024	055	084	115	145	176	206	237	268	298	329	359	24
25	025	056	085	116	146	177	207	238	269	299	330	360	25
26	026	057	086	117	147	178	208	239	270	300	331	361	26
27	027	058	087	118	148	179	209	240	271	301	332	362	27
28	028	059	088	119	149	180	210	241	272	302	333	363	28
29	029	060	089	120	150	181	211	242	273	303	334	364	29
30	030		090	121	151	182	212	243	274	304	335	365	30
31	031		091		152		213	244		305		366	31

Party City Holdings Inc.

Supplier Code of Conduct

Our Supplier Code of Conduct sets forth requirements for suppliers of our products with respect to labor standards and working conditions. The principles embodied in our Code are designed to be consistent with core conventions of the International Labor Organization (ILO), the specialized agency of the United Nations focused on global labor standards, codes set forth by key labor standards organizations, as well as codes required by brands, retailers and licensors who are customers of PCHI.

At PCHI, we are committed to:

- Integrity and excellence in every aspect of our business
- Ethical conduct in all of our operations;
- Respect for the rights of all individuals; and
- Protection and care for the environment.

We expect these same commitments to be shared by all suppliers of PCHI merchandise. At a minimum, we require that all suppliers of PCHI merchandise meet the following standards:

Child Labor

Suppliers shall not use child labor

The term “child” refers to a person younger than 15 (or 14 where local law allows) or, if higher, the local legal minimum age for employment or the age for the completing compulsory education.

Suppliers employing young persons who do not fall within the definition of “children” will also comply with any laws and regulations applicable to such persons.

Involuntary Labor

Suppliers shall not use any forced or involuntary labor, whether, prison, bonded, indentured or otherwise.

Coercion and Harassment

Suppliers shall treat each employee with dignity and respect, and shall not use corporal punishment, threats of violence or other forms of physical, sexual, psychological or verbal harassment or abuse.

Nondiscrimination

Suppliers shall not discriminate in hiring and employment practices, including salary, benefits, advancement, discipline, termination or retirement, on the basis of race, religion, age, nationality, social or ethnic origin, sexual orientation, gender, political opinion or disability.

Association

Suppliers shall respect the rights of employees to associate, organize and bargain collectively in a lawful and peaceful manner, without penalty or interference.

Health and Safety

Suppliers shall provide employees with a safe and healthy workplace in compliance with all applicable laws and regulations, ensuring at a minimum reasonable access to potable water and sanitary facilities, fire safety, and adequate lighting and ventilation. Suppliers will also ensure that the same standards of health and safety are applied in any housing that they provide for an employee and their immediate family.

Compensation and Benefits

We expect suppliers to recognize that wages are essential to meeting employees' basic needs. Suppliers shall, at a minimum, comply with all applicable wage and hour laws and regulations, including those relating to minimum wages, overtime, maximum hours, piece rates and other elements of compensation, and provide legally mandated benefits. Except in extraordinary business circumstances, suppliers shall not require employees to work more than the lesser of (a) 48 hours per week and 12 hours overtime or (b) the limits on regular and overtime hours allowed by local law or, where local law does not limit the hours of work, the regular work week plus 12 hours overtime. In addition, except in extraordinary

business circumstances, employees shall be entitled to at least one day off in every seven-day period.

Suppliers shall compensate employees for overtime hours at such premium rate as is legally required or, if there is no legally prescribed premium rate, at a rate at least equal to the regular hourly compensation rate.

Where local industry standards are higher than applicable legal requirements, we expect suppliers to meet the higher standards.

Protection of the Environment

Suppliers shall comply with all applicable environmental laws and regulations, including but not limited to those laws related to waste disposal, air emissions, discharges, toxic substances and hazardous waste disposal.

Other Laws

Suppliers shall comply with all applicable laws and regulations, including those pertaining to Emergency Preparedness, the manufacturing and distribution of PCHI merchandise, Immigration, Customs, Homeland Security, and International Financial Reporting Standards (IFRS) or Generally Accepted Accounting Principles (GAAP). All references to "applicable laws and regulations" in this Code of Conduct include local and national codes, rules and regulations, for example the Foreign Corrupt Practices Act (FCPA) and UK Bribery Act, as well as applicable treaties and voluntary industry standards in the markets where PCHI products are sold.

Subcontracting

Suppliers shall not use subcontractors for the manufacture of PCHI merchandise or components without written consent by PCHI, and only after the subcontractor has entered into a written commitment with PCHI to comply with this Code of Conduct.

Management Systems

Suppliers shall have management systems in place to ensure compliance with this Code of Conduct and maintain on site documentation that may be needed to demonstrate compliance with this Code of Conduct. Suppliers shall take appropriate measures to ensure that the provisions of this Code of Conduct are communicated to employees, including provision to an employee upon request and the prominent posting of a copy of this Code of Conduct in the local language and in a place readily accessible to all employees at all times.

PCHI reserves the right to take all appropriate measures, in accordance with applicable terms and conditions, against any vendor that fails to comply with this code.

Factory Name

Factory Address
TEL. No.

Certification Statement of Impact Resistance

RE:
IMPACT RESISTANCE TEST NO.:
PO#
INVOICE NO.:
COMMODITIES: SUNGLASSES
QUANTITIES: ___ PCS / ___ CARTONS
Date:

(Factory Name)

hereby guarantees that the articles listed herein are impact-resistant within the meaning of 21 CFR 801.410 and have been tested pursuant to that section. Impact-resistant lenses are not unbreakable or shatterproof. The lenses meet an AQL of 6.5 when tested by the drop ball test or an equal or superior test method. Records of testing will be maintained for a period of three (3) years from the date of shipment, and copies will be forwarded to FDA upon request.

Factory Name and Address:

(PLACE FACTORY'S CHOP STAMP HERE)



Certificate Of Fda Registration

2011.05-2012.05

This is certified that:
At The Address Stated Below Has Completed U.S. FOOD AND DRUG
ADMINISTRATION Medical Device Registration Through MANTON.

NINGBO HAISHU GOOD PARTNER TRADING CO.,LTD.
Add: Rm2401-2419, No.58, Lane 136, Shunde road
Ningbo, CHINA 315400

Proprietary Device Name	SUNGLASSES
Device Name(s)	SUNGLASSES (NON-PRESCRIPTION INCLUDING PHOTSENSITIVE)
Device Document Number	D048174
Product Code	HQY
Premarket Submission Number	Exempt
Owner/Operator Number	10025393
Date of Registration Status	2011
Registration Number	3006985453

MTG FDA *Jacky M. Chuang*
REGISTRATION *Jacky M. Chuang*
CENTER *Executive Director*
Date: 2011/04/28

CONCLUSION:

This certificate is only valid for the equipment and configuration described, in conjunction with the test data detailed above.

This certificate makes no other representations or warranties, nor does it imply any representation or warranty to any person or entity other than the named certificate holder. Manton assumes no liability to any person or entity in connection with the foregoing.

FDA NOTICE:

The fee should be paid as soon as possible after registering your device (print or submitting your annual establishment registration information electronically). Be sure to allow for enough time for your payment to be received and recorded. Your registration is not complete until FDA notifies you that all requirements have been met.



PCHI Guidelines for Children's & Other Products

			PCHI Requirement	Effective Date for Shipment Receipt by PCHI
Packaging (CONEG-Toxics in Packaging)				
	Lead, Cadmium, Mercury, Hexavalent Chromium	May not contain an aggregate total of these chemicals in excess of:	100 ppm	Already in Effect
Art Materials				
	Non-Toxic, TRA, LHAMA Compliant, Prop 65	Crayons, markers, paints, etc may not contain total lead in excess of: Artist Paints according to Prop 65:	90 ppm Lead: 12.5 ppm Cadmium: 2.5 ppm	Already in Effect Already in Effect
Children's Items (Toys*, Party Favors, etc for ages 0-14 yrs)				
* Toys cannot contain any of the following substances, if accessible during foreseeable use: a) carbon tetrachloride or any substance that contains it. b) methyl alcohol or any substance with greater than 1% methyl alcohol. c) petroleum distillates exceeding 10% by weight. d) benzene (under 100 ppm) e) turpentine or any substance with greater than 10% turpentine. f) boric acid or salts of boric acid. g) ethyl ether h) cobalt (under 40 ppm)	Lead (Pb) in Surface Coating Toy (<12 yrs) and Childcare (<6 yrs) items sold in Illinois Mercury (Hg) in Surface Coating Cadmium (Cd) in Surface Coating	May not contain total amount in excess of:	90 ppm 40 ppm 10 ppm 75 ppm (40 ppm WA)	Already in Effect Already in Effect Already in Effect Already in Effect
	Lead (Pb) in Substrate (plastic, wood, metal, rubber, etc.) Lead (Pb) in Substrate for Childcare (<6 yrs) items sold in Illinois Cadmium (Cd) in Substrate	Accessible(1) components may not contain total amounts in excess of:	90 ppm 40 ppm 75 ppm (40 ppm WA)	Already in Effect Already in Effect Already in Effect
Other Heavy Metals (soluble, surface coating and accessible substrate)				
	Mercury (Hg) [Substrate only] Antimony (Sb) Arsenic (As) Barium (Ba) Chromium (Cr) Selenium (Se)	May not contain Heavy Metals in excess of the limits specified:	60 ppm 60 ppm 25 ppm 1,000 ppm 60 ppm 500 ppm	Already in Effect Already in Effect Already in Effect Already in Effect Already in Effect
Phthalates: DBP, DEHP(DOP), BBP, DINP, DNOP, DIDP, DIOP, DIBP, DPP(DPENP), DNHP(DHEXP), DCHP, DEP, MBP (CAS#131-70-4) (3)	Accessible (1) Components of Mouthable (2) Toys and Childcare Articles for Children <3 years old. Apply to all child items in states of CA, ME, OR, VT & WA.		Under 0.1% under 1000 ppm	Already in Effect
<p>(1) Accessibility of a component determined before and after use & abuse testing. DBP, DEHP (DOP), BBP, DINP, DNOP, DIDP, DIOP, DIBP, DPP (DPENP), DnHP (DHEXP), DCHP are limited by CPSIA for mouthable, DBP, DEHP (DOP), BBP, DIOP, DIBP, DPP (DPENP), DnHP (DHEXP), DCHP for not mouthable. DIOP, DIBP, DPP (DPENP), DnHP (DHEXP), DCHP are under CPSC review.</p> <p>(2) For definition of "Mouthable" See CPSC Guidelines for CPSIA Section 108.</p> <p>(3) Limits apply to reusable or secondary packaging. Also note that for phthalate replacements,</p> <ul style="list-style-type: none"> • Manufacturers must use the least toxic alternative; • Manufacturers cannot replace the phthalate(s) with substance(s) rated by the United States (US) EPA as an A, B, or C carcinogen, or known by the US EPA to cause birth defects; and • Manufacturers cannot replace the phthalate(s) with substance(s) on the State list. (DnHP, DINP, & DIDP are Prop 65. DEP is WA/ME. DCHP & MBP are ME) 				

PCHI Guidelines for Children's & Other Products

		PCHI Requirement	Effective Date for Shipment Receipt by PCHI
(Other Non-Children's Products): Phthalates DEHP, BBP, DBP, DnHP, DIDP and DINP Lead in Substrate and Surface Coating Cadmium in Substrate and Surface Coating Mercury in Surface Coating	Presence as defined by:	Prop 65: 0.1% for phthalates Under 90 ppm total (or lower as required by law) Under 300 ppm total Under 10 ppm total	Already in Effect Already in Effect Already in Effect Already in Effect
Jewelry – Children (0-14yrs): Lead – Surface Coating and Substrate Cadmium (Cd) – Surface Coating and Substrate Cobalt (Co) – Surface Coating and Substrate Mercury (Hg) – Surface Coating Other Heavy Metals – Surface Coating Antimony (Sb) Arsenic (As) Barium (Ba) Chromium (Cr) Nickel (Ni) Selenium (Se) Benzene	May not contain total Pb in excess of: May not contain total Cd in excess of: May not contain total Hg in excess of: May not contain soluble levels in excess of: Metal Jewelry substrates may not contain soluble heavy metals (using EN-71, Part 3) in excess of the limits specified:	90 ppm (40 ppm limit for Illinois) 75 ppm (40 ppm for WA) 40 ppm 10 ppm ASTM 963 levels below: 60 ppm 25 ppm 1000 ppm 60 ppm 500 ppm 930 ppm 100 ppm	Already in Effect Already in Effect Already in Effect Already in Effect Already in Effect Already in Effect Already in Effect Already in Effect Already in Effect Already in Effect
Jewelry – Adults: Lead – Surface Coating & Substrate Cadmium (Cd) – Surface Coating and Substrate Mercury (Hg) – Surface Coating	May not contain total lead in excess of: May not contain total Cd in excess of: May not contain total Hg in excess of: (Other Heavy Metals subject to Children's Jewelry requirements above)	90 ppm 75 ppm 10 ppm	Already in Effect Already in Effect Already in Effect
Food Contact Material	For a definition of food contact material and the applicable limits see:	www.fda.gov/ora/compliance%5Fref/cpg/cpgfod/ and Prop 65	Already in Effect
Cosmetics	May not contain total amounts of Heavy Metals in excess of:	Lead (Pb) – 5 ppm, Mercury (Hg) – 1 ppm Arsenic (As) - 3 ppm, Cadmium (Cd) - 3 ppm, Antimony (Sb) - 5 ppm, Chromium (Cr) – 50 ppm, Manganese (Mn) - 100 ppm Other Heavy Metals use Child Jewelry soluble limits above.	Already in Effect
Mercury (mercury-free batteries, etc.)	May not contain Mercury	No Detectable Level	Already in Effect
Brominated and Other Flame Retardants	May not contain Penta BDE, Octa BDE, TDCPP, TCEP, TCPP and Antimony Trioxide:	No Detectable Level	Already in Effect
Formaldehyde – Fabrics and Textiles	May not have levels in excess of:	20 ppm (ages and sizes <3 years old) 75 ppm (ages and sizes 3 years old and above)	Already in Effect
Bisphenol A (BPA)	May not contain BPA (Provide childcare product labeling per WI law)	No detectable level over 1 ppm	Already in Effect
Formaldehyde - Products made from Composite Woods: Products offered for sale in California must comply with the requirements of the California Air Resource Board (CARB) Airborne Toxics Control Measure (ATCM) by maintaining chain of custody documentation which certifies use of compliant raw materials.			Already in Effect
Traceability: Please refer to our Vendor Standards Manual, where we encourage placement of the Julian date code and factory code on each package surface (master, inner, and each) to enable determination of the day, year and location of production. If the "each" does not have a package, the date and factory codes should be placed on the product. Children's products will need permanent distinguishing marks on the product, to the extent practicable, to identify the item#, manufacturer, and location and date of production, for all goods manufactured on or after 8/14/09 as follows: "www.amscan.com - vendor#_item#_year_country of origin"			
For Additional Information or questions, please contact: Ray Cheung (Hong Kong): rcheung@amscan.asia or Hsin Chen (USA): hchen@amscan.com			

Special Provision 130

(49 CFR 172.102)

130 Dry batteries not specifically covered by another entry in the §172.101 Table must be described using this entry. Batteries described as “Batteries, dry, sealed, n.o.s” are hermetically sealed and generally utilize metals (other than lead) and/or carbon as electrodes. These batteries are typically used for portable power applications. The rechargeable (and some non-rechargeable) types have gelled alkaline electrolytes (rather than acidic) making it difficult for them to generate hydrogen or oxygen when overcharged and therefore, differentiating them from non-spillable batteries. “Batteries, dry, sealed, n.o.s.” are not subject to any other requirements of this subchapter except for the following:

(1) Incident reporting requirements. For transportation by aircraft, a telephone report in accordance with §171.15(a) is required if a fire, violent rupture, explosion or dangerous evolution of heat (*i.e.* , an amount of heat sufficient to be dangerous to packaging or personal safety to include charring of packaging, melting of packaging, scorching of packaging, or other evidence) occurs as a direct result of a dry battery. For all modes of transportation, a written report submitted, retained, and updated in accordance with §171.16 is required if a fire, violent rupture, explosion or dangerous evolution of heat occurs as a direct result of a dry battery or battery-powered device;

(2) Batteries and battery-powered device(s) containing batteries must be prepared and packaged for transport in a manner to prevent:

(i) A dangerous evolution of heat;

(ii) Short circuits, including but not limited to the following methods:

(a) Packaging each battery or each battery-powered device when practicable, in fully enclosed inner packagings made of non-conductive material;

(b) Separating or packaging batteries in a manner to prevent contact with other batteries, devices or conductive materials (*e.g.* , metal) in the packagings; or

(c) Ensuring exposed terminals or connectors are protected with non-conductive caps, non-conductive tape, or by other appropriate means; and

(iii) Damage to terminals. If not impact resistant, the outer packaging should not be used as the sole means of protecting the battery terminals from damage or short circuiting. Batteries must be securely cushioned and packed to prevent shifting which could loosen terminal caps or reorient the terminals to produce short circuits. Batteries contained in devices must be securely installed. Terminal protection methods include but are not limited to the following:

(a) Securely attaching covers of sufficient strength to protect the terminals;

(b) Packaging the battery in a rigid plastic packaging; or

(c) Constructing the battery with terminals that are recessed or otherwise protected so that the terminals will not be subjected to damage if the package is dropped.

(3) When transported by aircraft, for a battery whose voltage (electrical potential) exceeds 9 volts:

(i) When contained in a device, the device must be packaged in a manner that prevents unintentional activation or must have an independent means of preventing unintentional activation (*e.g.* , packaging restricts access to activation switch, switch caps or locks, recessed switches, trigger locks, temperature sensitive circuit breakers, etc.); and

(ii) An indication of compliance with this special provision must be provided by marking each package with the words “not restricted” or by including the words “not restricted” on a transport document such as an air waybill accompanying the shipment.